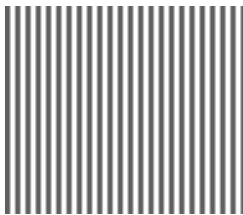

INST. No. INE-308H

CHINO

AL3000 SERIES (PEN TYPE)
AH3000 SERIES (PEN TYPE)

**HYBRID
RECORDERS**

 **INSTRUCTIONS**

CHINO

■ Preface: Request and notice

This instruction describes pen type AL3000 series hybrid recorder (100 mm printing width) and pen type AH3000 series hybrid recorder (180 mm printing width).

In order to use your recorder correctly and safely and to prevent malfunctions, please read this instruction manual carefully.

Other instruction manuals to be provided separately

This instruction manual describes the operation under the standard specifications and also operations for the optional specifications of (1) alarm output/remote contacts and (2) printing format. For the communications interface unit and the optional specification of mathematical function/totalization, exclusive manuals are provided separately. Also for other optional specifications, of which description of operation is necessary, the relevant instruction manuals are provided respectively. Please read these together with this instruction manual if necessary.

Requests

1. To agents or distributors
Make sure to pass this instruction manual to final customers.
2. To our valuable customers
Keep this instruction manual until disposing of your recorder.

Notices

1. All or any part of this manual may not be duplicated or reproduced in any form, without first obtaining the permission of CHINO.
2. The details of this manual may be subject to change without notice.
3. The contents in this instruction manual have been carefully checked. However, if any question should still arise or if any error, omission or other deficiency be found, please inform your local CHINO sales agent of the details.
4. CHINO will not be responsible for any troubles resulting from the operations of your recorder.

Contents (1)

Read the Following Instructions Without Fail

- Preface: Request, Guarantee and Notice 1
- ▲ FOR SAFE USE 4
- ▲ WARNINGS 5
- MAJOR FEATURES AND FUNCTIONS 6

Introduction

- 1. GENERAL 7
 - 1.1 Confirmation of Model No. 7
 - 1.2 Accessories and Consumables 8

Preparation

- 2. INSTALLATION 9
 - 2.1 Location and External Dimensions 9
 - 2.2 Installation to a Panel ▲ 10
- 3. CONFIGURATION 11
 - 3.1 Front ▲ 11
 - 3.2 Display 12
- 4. CONNECTIONS 13
 - 4.1 Terminal Board Arrangement 13
 - 4.2 Cautions on Connections ▲ 14
 - 4.3 Power Terminals ▲ 15
 - 4.4 Measuring Input Terminals ▲ 16
 - 4.5 Alarm Output Terminals ▲ 17
 - 4.6 Remote Contacts Terminals ▲ 18
 - 4.7 Communications terminals 19
- 5. INSTALLATION 21
 - 5.1 Chart Paper Loading (AL3000) 21
 - 5.2 Chart Paper Loading (AH3000) 23
 - 5.3 Recording Pen Loading 25

Basic Operation

- 6. BASIC OPERATION 27
 - 6.1 Power Supply and Operation 27
 - 6.2 Printing ON/OFF and chart end detection 28
 - 6.3 Fast Feeding of Chart Paper 29
 - 6.4 Switching Operation Screen (AL3000) 30
 - 6.5 Switching Operation Screen (AH3000) 31

Programming

- 7. PROGRAMMING 32
 - 7.1 Keys and Characters 32
 - 7.2 Key Functions 33
 - 7.3 List of Programming Items 34
 - 7.4 Programming Procedures 37
 - 7.5 Programming Errors and Remedial Measures 38
- 8. BASIC PROGRAMMING 39
 - 8.1 Programming Parameters Before Operation 39
 - 8.2 Range/Printing Range 40
 - 8.3 °C / °F computation Selection 43
 - 8.4 Chart Speed Programming 44

Operations and Functions

- 9. PRINTINGS 45
 - 9.1 Printing Types and the Details 45
 - 9.2 Digital Data Printing 47
 - 9.3 List Printing 48
 - 9.4 Message Printing 50
 - 9.5 Printing Format selection 51
 - 9.6 Time Axis Sync. (POC) 52
- 10. OPERATIONS 53
 - 10.1 Fixed-Time Printing and Intervals 53
 - 10.2 Operations at Abnormal Inputs
54
 - 10.3 Alarm Display and Printing
55

The items marked with ▲ in titles contain ▲ **Warning** and ▲ **Caution**. Read these items without fail.

Contents (2)

Other Programmable Parameters / Functions

11. OTHER PROGRAMMING	56
11.1 Time	56
11.2 Scale	57
11.3 Skip (Channel Deletion)	59
11.4 Subtract Printing	61
11.5 Alarm	63
11.6 Alarm Dead Band	67
11.7 Periodic Data Printing	68
11.8 Engineering Units	69
11.9 Tags	71
11.10 Message	73
11.11 Burnout	75
11.12 Passcode / Key Lock	76
11.13 Input Filter	79
11.14 Copying to Other channels	80

Options

12. ALARM OUTPUT	81
12.1 Alarm Output Programming Items	81
12.2 Programming of Relay No.	82
12.3 Output Wiring (AND/OR) Setting	83
12.4 Programming Output Mode	84
13. REMOTE CONTACTS	87
13.1 Remote Contacts Functions	87
13.2 Terminal Allocation for Operation	89
13.3 Programming 3 Chart Speeds	90
13.4 Programming Operation Recording Position ..	91
14. PRINTING FORMAT	92
14.1 Programming Automatic Range-Shift Printing ..	92
14.2 Programming Compressed/Expanded Printing ..	94
14.3 Programming Zone Printing	96
15. COMMUNICATIONS INTERFACE	99
15.1 Programming Communications Protocol	99
15.2 Programming Communications	100

16. Maths Expressions and Totalization	101
--	-----

17. Other Options	102
17.1 Shunt Resistor for Current Input	102
17.2 Transmitter Power Supply	103





Maintenance Functions

18. ADJUSTMENT	104
18.1 Adjustment of Measured Values	104
18.2 Shift Programming of Measured Value	107
18.3 Adjustment of Printing Position	108
18.4 Time Axes Adjustment of Pen	109

19. HARDWARE CHECK	110
19.1 ROM Version Check	110
19.2 Printer Check	111
19.3 Display Check	112
19.4 Measuring Input Check	113
19.5 Alarm Output Check	114
19.6 Remote Contacts Input Check	115
19.7 Communications IF Check	116

20. MEMORY CLEAR	118
------------------------	-----

Maintenance

21. MAINTENANCE	119
21.1 Daily Inspection	119
21.2 Cleaning and Lubrication 	120
21.3 Measuring Values Check 	121
21.4 Troubleshooting 	123
21.5 Recommended Parts Replacement Intervals 	125

22. SPECIFICATIONS	126
--------------------------	-----

The items marked with  in titles contain  **Warning** and  **Caution**. Read these items without fail.

FOR SAFE USE

1. Preconditions for Use



Your recorder is designed for indoor use by mounting it on an indoor instrumentation panel. (exception: portable types)

International safety standards ... The alarm output (option) with the “c” contact mechanical relay does not conform to the following standards.

- IEC standards Conforms to safety class I (with PROTECTIVE CONDUCTOR TERMINAL) and IEC1010-1 (OVERVOLTAGE CATEGORY II, POLLUTION DEGREE 2)
- Enclosure productivity Conforms to IEC529 (IP54)
- CE (EC Directive) EMC : Conforms to EN61326
Safety : Conforms to EN61010-1 +A2
- UL standards UL3111-1 (Approval pending)
- CSA (C-UL) standards CSA C22.2 No. 1010 (Approval pending)







2. Labels on This Instrument

The following labels are used for safe use.

Label	Name	Meaning
	Alert symbol mark	Caution on handling for prevention of an electric shock, injury or other accidents.
	Protective conductor terminal	A terminal is provided for connection to the protective conductor of the power supply facility in order to prevent any electric shocks.

3. Symbols in This Manual

Cautions to be observed for preventing damage to your recorder and unexpected accidents are indicated by the following symbols according to their degree of importance.

Symbols	Meaning of symbols
	This symbol is shown together with relevant titles (or items) where  Warning or  Caution is attached. Read them with care.
	This symbol indicates a description of cautions for avoiding the possibility of causing serious injury or death due to an electric shock or other accident.
	This symbol indicates a description of cautions for avoiding the possibility of causing slight injury to a person or damage to your recorder or to peripheral units.
	This symbol shows a caution when your recorder does not function as specified or when such a possibility exists.
	This reference serves to indicate supplementary information for handling and operation for your convenience.

⚠ WARNINGS

This paragraph covers important warnings for safety to be observed before reading the instructions. A full understanding of the following warnings is required. These warnings are important for the prevention of danger to human bodies as well as accidents with your recorder.

1. Switch and overcurrent protective device

Your recorder is not provided with a power switch or a replaceable overcurrent protective device. Prepare a switch and an overcurrent protective device (circuit breakers, circuit protectors or similar units) for the power supply within 3 m of your recorder in a location where you can reach easily.

Use a switch and an overcurrent protective device conforming to IEC948-1 and IEC947-3.

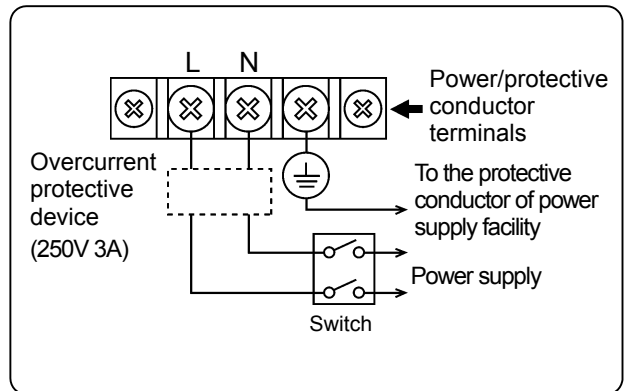

2. Be sure to ground your recorder

Before turning on the power, connect the protective conductor terminal your recorder to the protective conductor of the power supply facility. Do not disconnect this wiring in running of your recorder to prevent an electric shock.

3. Before turning on the power supply

In order to ensure safety, before turning on the external power switch, make sure that the power voltage is within the range indicated on the power supply label.

4. Don't repair or modify your recorder.

Make sure that a service engineer approved by the CHINO CORPORATION is ONLY permitted to repair or modify your recorder by replacing parts. Otherwise, it may be damaged or will not function correctly, or an accident such as an electric shock may result. For usual operation, it is not necessary to pull out an internal unit from a case.

Reference Fuse in power supply unit

The following fuse is mounted in the power supply unit of your recorder for safety use. However, this fuse is not replaceable.

Manufacturer	Model	Ratings
SCHURTER	SPT001.2508	250VAC 2.5A
LITTEL FUSE	21502.5	
WICKMANN	19181	

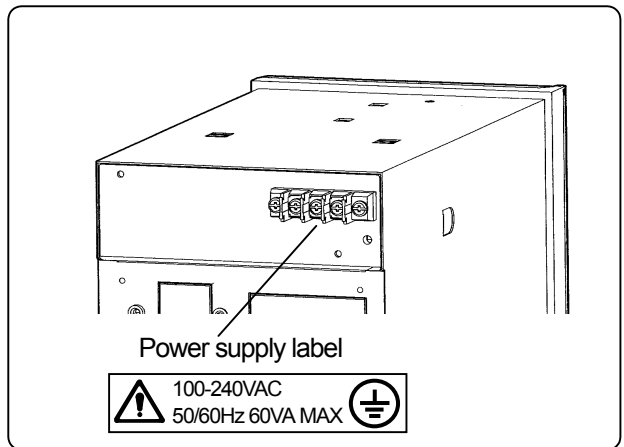

Note: This figure is for AL3000 series.

5. Use your recorder in accordance with this instruction manual.

Use your recorder correctly and safely in accordance with this instruction manual. CHINO CORPORATION will not be responsible for any injury, damage, lost profit or any other claim, which may result from its wrong use.

6. Turn off the power supply if an abnormal symptom occurs.

If any abnormal odor, noise or any smoke occurs, or if your recorder becomes too hot to be touched, turn off the power supply immediately and contact your local CHINO sales agent.

MAJOR FEATURES AND FUNCTIONS

Your recorder can record temperature and other various industrial variables on a 100 mm (if your recorder is AL3000) or 180 mm (if your recorder is AH3000) chart for 1 to 4 channels (depending on the number of pens).

- (1) Trace printing by pens
- (2) Digital data printing to print measured values and other data

1 Features

Major features are shown below.

- Universal input. A range can be selected optionally for every channel from 10 DC voltage ranges, 36 thermocouple ranges and 11 resistance thermometer ranges.
- Universal power supply. The working voltage range is 100 to 240 V AC, 50/60 Hz.
- International safety standards... CE: Conformance, UL and CSA (C-UL): Approval pending
- The basic operation should be carried out after programming range numbers and the trace printing range.
- You can execute all operation by the front keyboard without pulling out the internal unit. The internal unit cannot be pulled out.

2 Functions

Major functions are shown below.

Display	Printing
<ul style="list-style-type: none"> ● Simultaneous display of the measured values for 1 to 4 channels. ● Analog indication of measured values for 1 to 4 channels with bargraphs. ● Six status lamps ● Switching the operation screens (Measured value, Clock and Alarm Activation) ● Measured values blinks when alarm activates. (Note) 	<ul style="list-style-type: none"> ● Trend tracing for 1 to 4 channels ● Fixed-time printing (time line, time, scale, engineering unit, tag) ● Periodic data printing (Measured values are digitally printed at preset intervals.) ● Digital data printing (Measured values are digitally printed on demanding.) ● Message printing ● On or off of time axis synchronization (POC)

(Note) Programming of alarm is necessary. Alarm output is only available when your recorder is with the option of "Alarm Output".

MEMO

A large, empty rectangular frame with rounded corners, intended for writing a memo. The frame is defined by a thin, dark border. The interior of the frame is completely blank, providing a space for the user to write their memo.

1. GENERAL

1.1 Confirmation of Model No.

Pen type AL3000 series and AH3000 series have various specifications. Confirm Model No. of your recorder. Labels showing Model No. are affixed to the top side of the case and to the inside of the internal unit.

AL3000

AL373P-R20 - 00A Model
AL00 X A001 Serial No.
MADE IN JAPAN

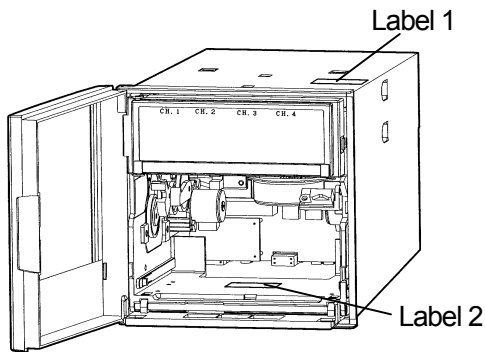

AH3000

AH374P - SA0 - 00A Model
AH00 X A001 Serial No.
MADE IN JAPAN

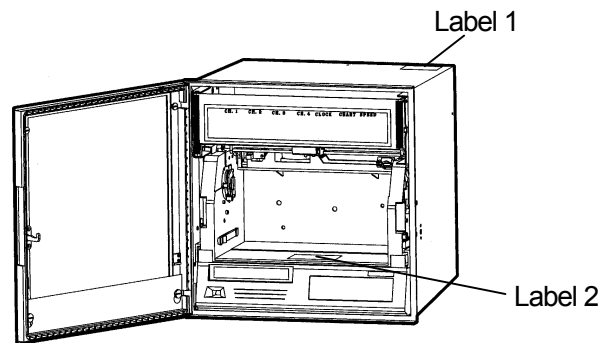

Note: For pulling out a chart cassette, refer to Section 5.1.

Models

A L 3 7 □ P - □ □ □ - □ □ □
 A H 3 7 □ P - □ □ □ - □ □ □
 (A) (B) (C) (D) (E) (F) (G) (H) (I) (J)

- (A) Series name
AL3: AL3000 (100 mm) AH3: AH3000 (180 mm)
- (B) Universal input (Fixed)
- (C) No. of input points (pens)/measuring cycle
1: 1 ch. (1 pen)/100 ms 2: 2 ch. (2 pens)/100 ms
3: 3 ch. (3 pens /100 ms 4: 4 ch. (4 pens)/100 ms
- (D) Pen type (Fixed)
- (E) Communications interface (Optional)
N: None R: RS-232C A: RS-422A S: RS-485
E: Ethernet
- (F) Alarm output and remote contacts (Optional)
0: None
1: 6 MOS relay outputs + remote contacts
2: 6 mechanical relay "c" contact outputs + remote contacts*
3: 12 MOS relay outputs + remote contacts
4: 12 mechanical relay "c" contact outputs + remote contacts*
A: 6 mechanical relay "a" contact outputs + remote contacts
B: 12 mechanical relay "a" contact outputs + remote contacts
*Not conforming to CE marking, UL and CSA.
(Note) For AL3000, "0", "1", "2" and "A" are only available.
- (G) Printing format (Optional)
0: Standard
1: Printing format
- (H) Math-function (Optional)
0: None
1: Basic math-function
2: Totalizer & flow correction
3: Basic math-function + Totalizer & flow correction
- (I) Exterior design (Optional)
0: Standard
1: With carrying handle & rubber stands
2: Die-cast door for AL
3: With carrying handle & rubber stands + Die-cast door for AL
- (J) Power supply (Fixed)
A: 100 - 240 V AC

1. GENERAL

1.2 Accessories and Consumables

1 Accessories attached

AL3000

Names	Qty	Remarks
(1) Chart	1	EM001 (0 - 100)
(2) Mounting bracket	2	For installation to a panel.
(3) Channel indicating card	1	Inserted inside the door.
(4) Cartridge pen (Red)	1	
(5) Cartridge pen (Green)	1	Only for 2 to 4-pen type
(6) Cartridge pen (Blue)	1	Only for 3 to 4-pen type
(7) Cartridge pen (Brown)	1	Only for 4-pen type
(8) Plotter pen	1	
(9) Terminal screw	5	Spare
(10) Lubricating oil	1	For the main shaft of the plotter pen
(11) Instruction manual	1	This manual

AH3000

Names	Qty	Remarks
(1) Chart	1	EH01001 (0 -100)
2) Mounting bracket (left, right)	1 set	For installation to a panel.
(3) Channel indicating card	1	Inserted inside the door.
(4) Cartridge pen (Red)	1	
(5) Cartridge pen (Green)	1	Only for 2 to 4-pen type
(6) Cartridge pen (Blue)	1	Only for 3 to 4-pen type
(7) Cartridge pen (Brown)	1	Only for 4-pen type
(8) Plotter pen	1	
(9) Terminal screw	5	Spare
(10) Lubricating oil	1	For the main shaft of the plotter pen
(11) Instruction manual	1	This manual
(12) Wrench	1	For tightening mounting brackets

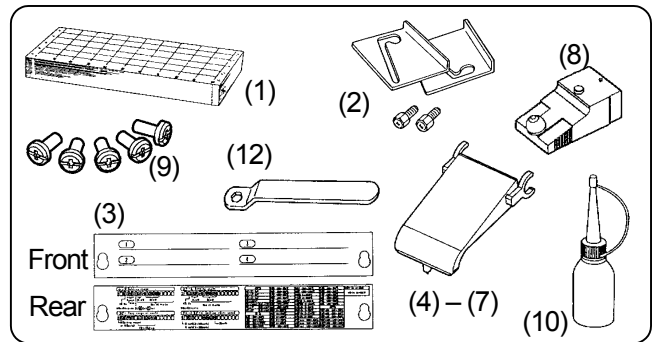
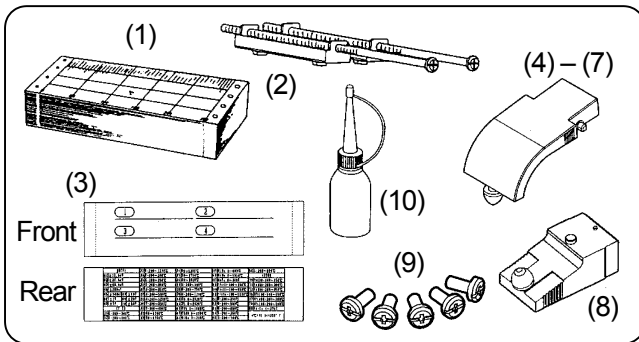

Note Separate instruction manuals are attached when your recorder is with the options of "Communications interface" and "Math-function and totalizer".

2 Consumables

Charts and pens are consumables. For your ordering, refer to the following table.

AL3000

Article	Model	Min. qty	
Cartridge pen	Red (1 st pen)	3 pieces/ bag for each color	
	Green (2 nd pen)		
	Blue (3 rd pen)		
	Brown (4 th pen)		
Plotter pen	Purple	22025-425331	3 pieces/ box
Chart	10 meters	EM001 (0 - 100)	15 charts/ box
	16 meters	KL01001 (0 to 100)	

AH3000

Article	Model	Min. qty	
Cartridge pen	Red (1 st pen)	3 pieces/ bag for each color	
	Green (2 nd pen)		
	Blue (3 rd pen)		
	Brown (4 th pen)		
Plotter pen	Purple	22025-425331	3 pieces/ box
Chart	20 meters	EH01001 (0 to 100)	15 charts/ box

2. INSTALLATION | 2.1 Location and External Dimensions

1 Location

Install your recorder at the following place so as not to affect the measuring accuracy and recording operation unfavorably.

(1) Industrial environment

Select a place being separated from electric field and magnetic field generating sources and also free of mechanical vibrations and shocks.

- Overvoltage Category II
- Pollution Degree 2
- Altitude..... 2000m or lower
- Working place Indoors

(2) Atmosphere

Install your recorder in a place where no inflammable gas exists and no dust, smoke, vapor, or other dangerous substance exists.

(3) Ambient temperature and humidity

Make sure not to expose your recorder to direct sunlight and not to closely place other materials to it for preventing rise of its temperature.

- The recommended ambient temperature and humidity are about 23°C and about 50%RH.
- Make sure not to expose your recorder to hot air higher than 70°C.
- Make sure not place any heat source near to the terminal board of your recorder.

(4) Mounting angle and display view angle

- Lateral tilting..... 0° to 10°
- Longitudinal tilting..... Forward tilting: 0°
Backward tilting: 0 to 30°
- View angle ... -10° to +30° based on horizontal

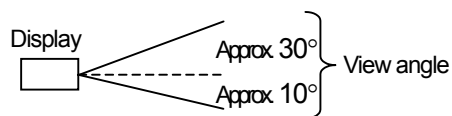

2 External Dimensions

AL3000

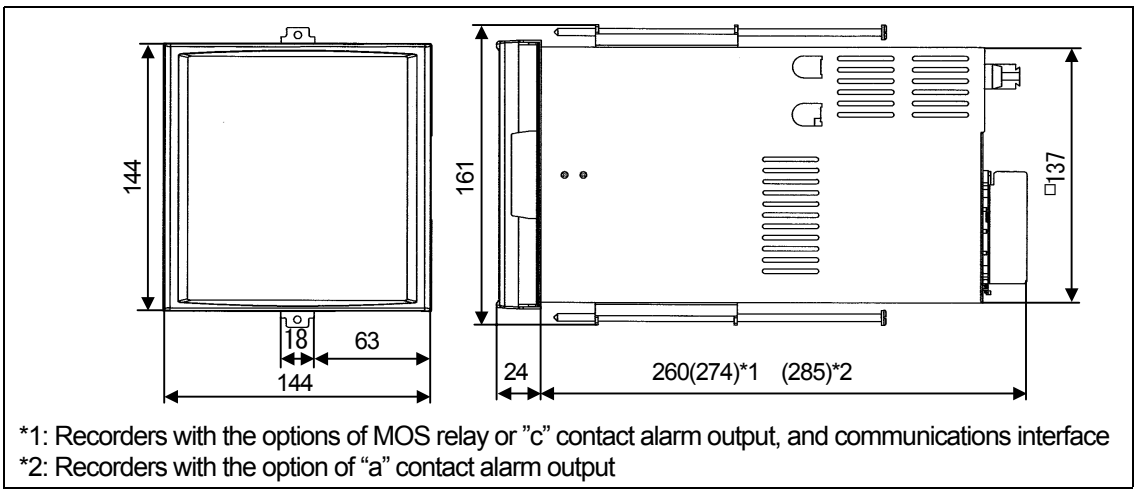

AH3000

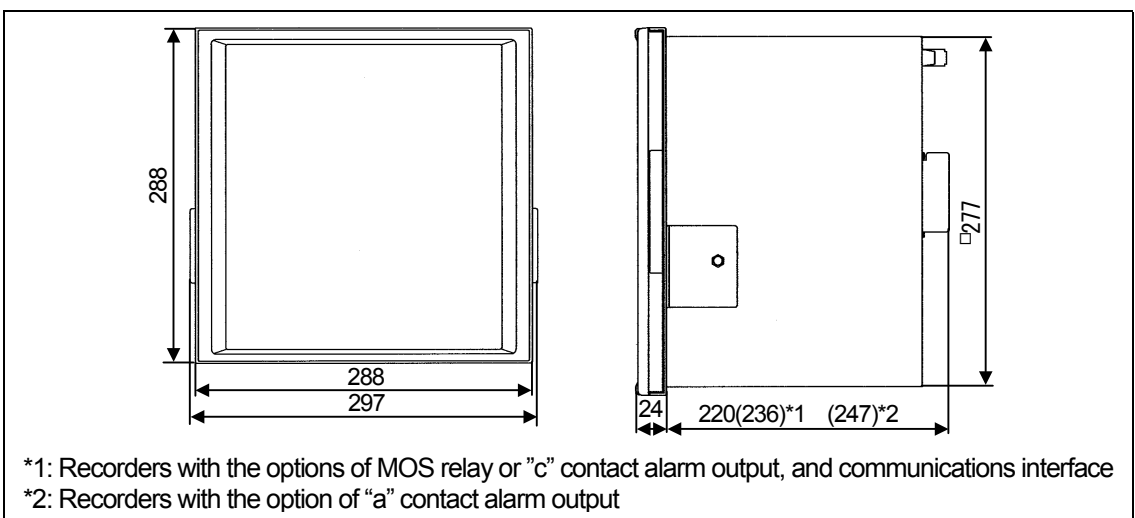

2. INSTALLATION 2.2 Installation to a Panel

Warning Install your recorder to a panel.

Except portable types, your recorder is designed to install to a panel. Use a panel made of a steel plate of 2 mm to 6 mm in thickness.

AL3000

1 Panel cutout size

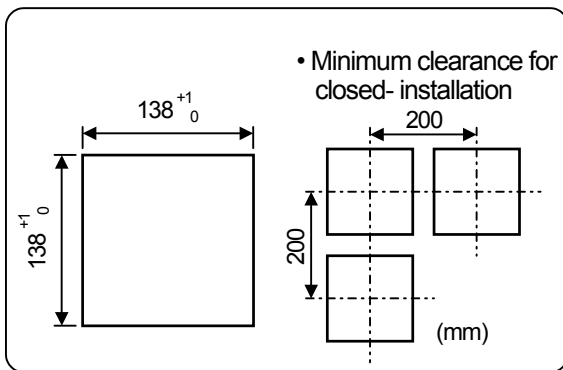

2 Installation

- (1) Insert your AL3000 (pen type) into the panel cutout from the front of the panel.
- (2) Fix your AL3000 (pen type) to the panel by the mounting brackets (screw tightening torque: 1.0 N•m). Attach 2 mounting brackets to the top and bottom of this instrument.

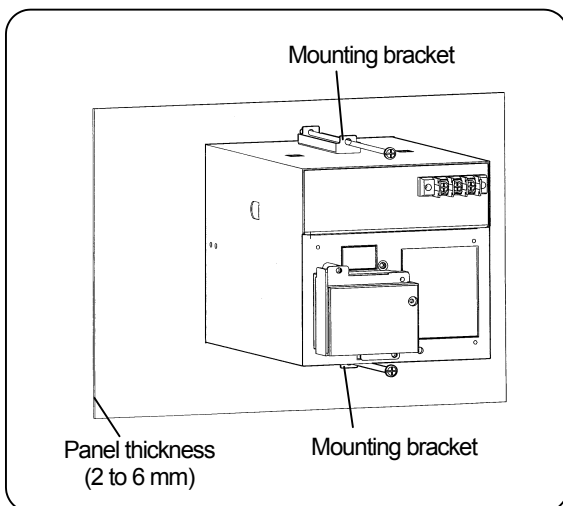

AH3000

1 Panel cutout size

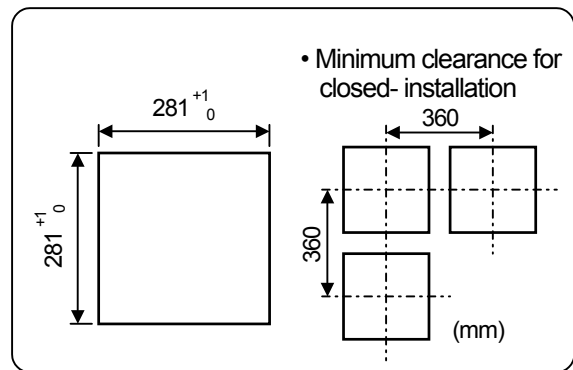

2 Mounting method

- (1) Insert your AH3000 (pen type) into the panel cutout from the front of the panel.
- (2) Gently screw a mounting screw into the screw hole of the case (left, right).
- (3) Attach the mounting bracket to the case by putting the mounting screw in the large hole of the bracket. Slide the bracket downward to attach it closely to the panel and then tighten the screw with a wrench (screw tightening torque: 1.2 N•m).

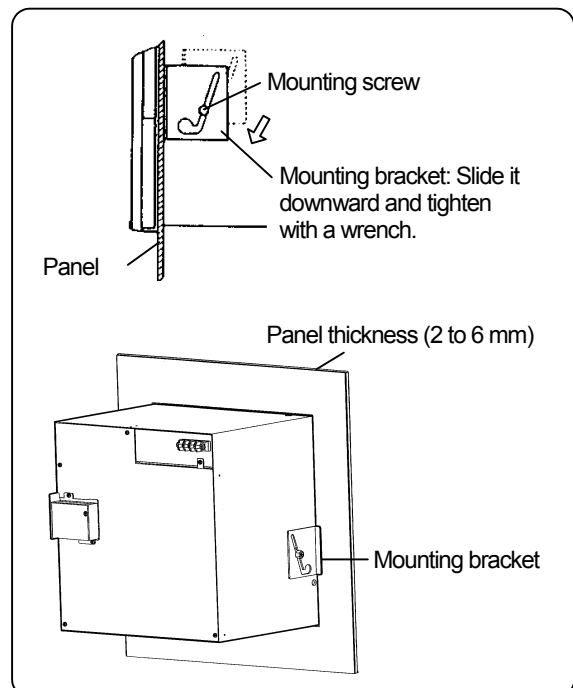

3. CONFIGURATION

3.1 Front

All operations of your recorder including the loading of pens can be executed from its front.

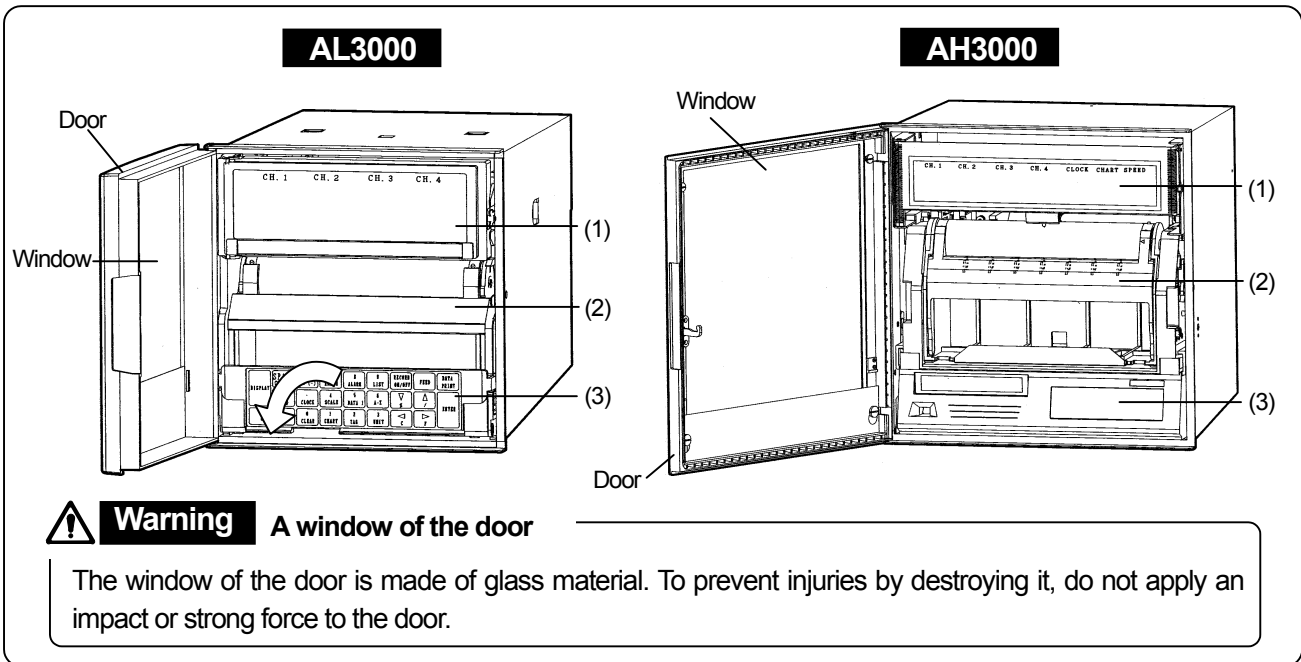

(1) Display panel

The display panel is consisted of character displays, status lamps and bargraph displays.

For loading the pens, open the display panel by swinging it out from the right side. An illumination for chart is mounted on the back of the display panel.

(2) Chart paper cassette

The chart paper cassette is for loading a chart to your recorder. Remove it for the loading of chart. When your recorder is AL3000, remove the chart paper cassette by swinging down the keyboard.

(3) Keyboard

The sheet switch type keys are used in the keyboard.

● Operation keys

Keys	Operations	Ref. page	Keys	Operations	Ref. page
DISP	Switches operation screen.	6.4	SHIFT + 9 LIST	List printing	9.3
ENTRY	Stops blinking of display.	10.3	*1 → ENTRY		
REC ON/OFF → ENTRY	Switches printing on/off	6.2	0 CLEAR + 6 A~Z (3 sec. or more)	Message printing	9.4
FEED	Fast forwarding of chart	6.3	*2 → ENTRY		
DATA PRINT → ENTRY	Digital data printing	9.2	REC ON/OFF (3 sec. or more) (With recording disabled)	Pen replacing mode	5.3

*1: Selection of List 1 or List 2. *2: Selection of Message No. (1 to 5)

● Programming keys

The keys are different on programming items. See Section 7.3 for details.

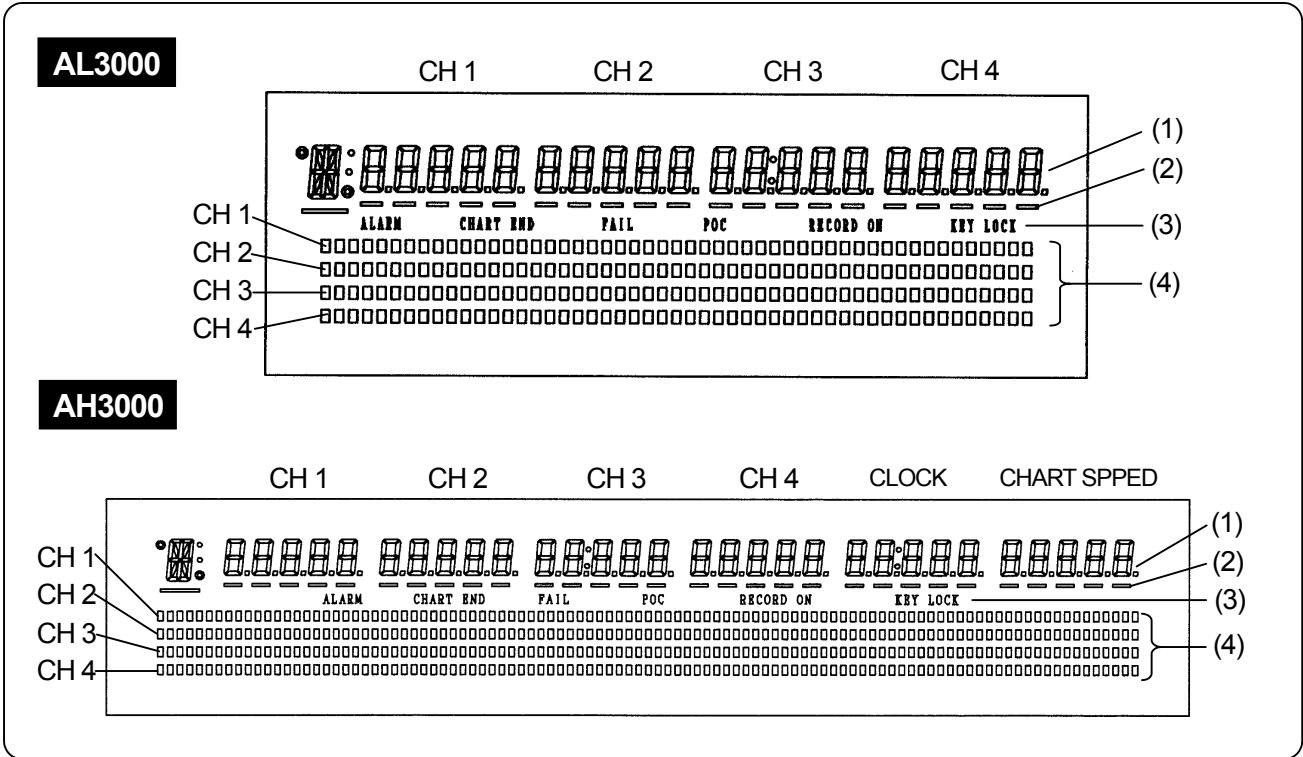

(1) Characters

- Operation mode: Displays measured value, time, chart speed, and alarm status of each channel (CH). See Section 6.4 for details.
- Programming mode: Displays programming items and programming parameters in an interactive method.

(2) Underline

Shows the trace printing color of each channel (CH).
 (CH 1: Red, CH 2: Green, CH3: Blue, CH 4: Brown)

These underlines also function as a cursor appearing at the digit for programming parameter in the programming mode.

(3) Status

Display	Lighting condition	Section
ALARM	When an alarm activates.	10.3
CHART END	When the end of chart is detected.	6.2
FAIL	When the hardware related to servo-circuit/mechanism is abnormal.	
POC	When the time axis synchronization is enabled.	9.6
RECORD ON	When the printing is on (enable).	6.2
KEY LOCK	When the keys are locked.	11.12

(4) Bargraph

The bargraphs indicate the measured value of each channel in an analog form. These indications are interlocking to the positions of the pens for trace printing.

Resolution AL3000: 1/50 (2%), 51 segments
 AH3000: 1/100 (1%), 101 segments

4. CONNECTIONS 4.1 Terminal Board Arrangement

The terminal boards shown in the following figure are of recorders with the options (alarm output + remote contacts and communications interface).

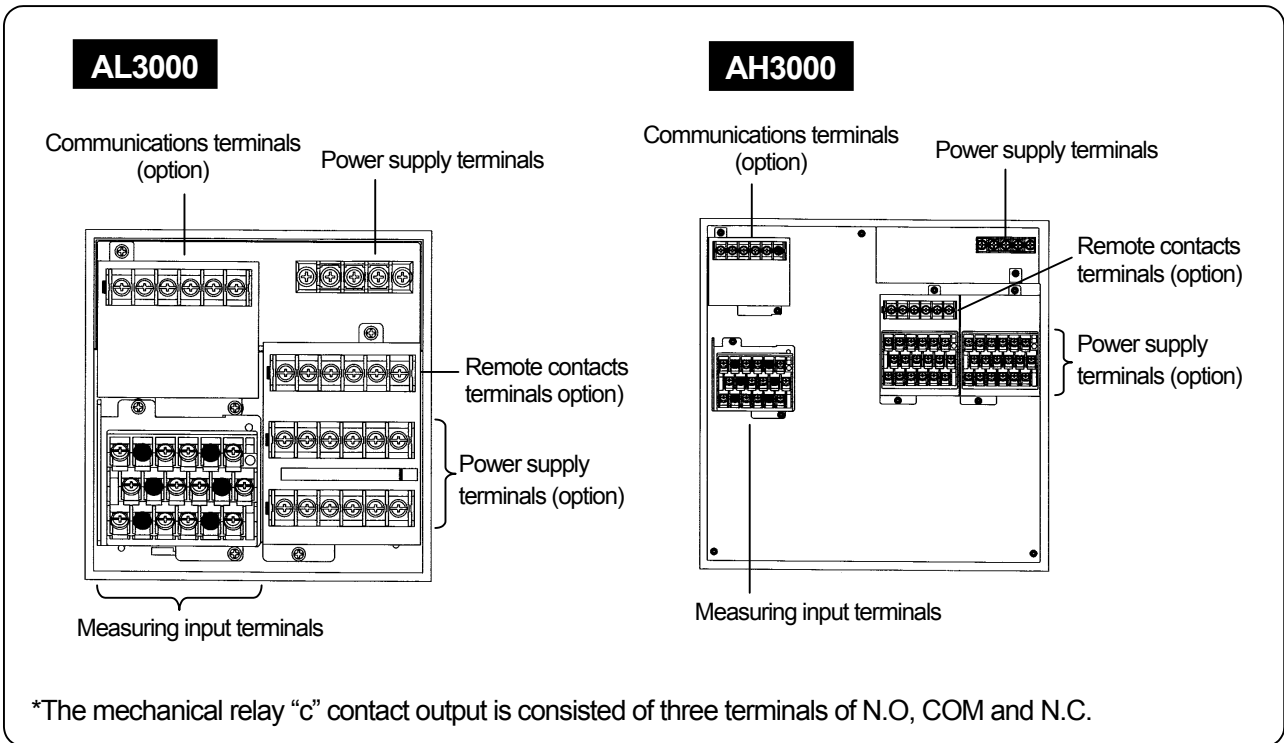

Reference The input terminal and alarm terminal blocks are removable.

The input terminal block and alarm terminal block (including the remote contacts terminal block) are removable for easy connections. Each terminal block can be taken out by removing two mounting screws. Each terminal block is connected to your recorder by a connector. For mounting or dismounting the terminal block, turn off the power switch to prevent the electric circuits from being damaged.

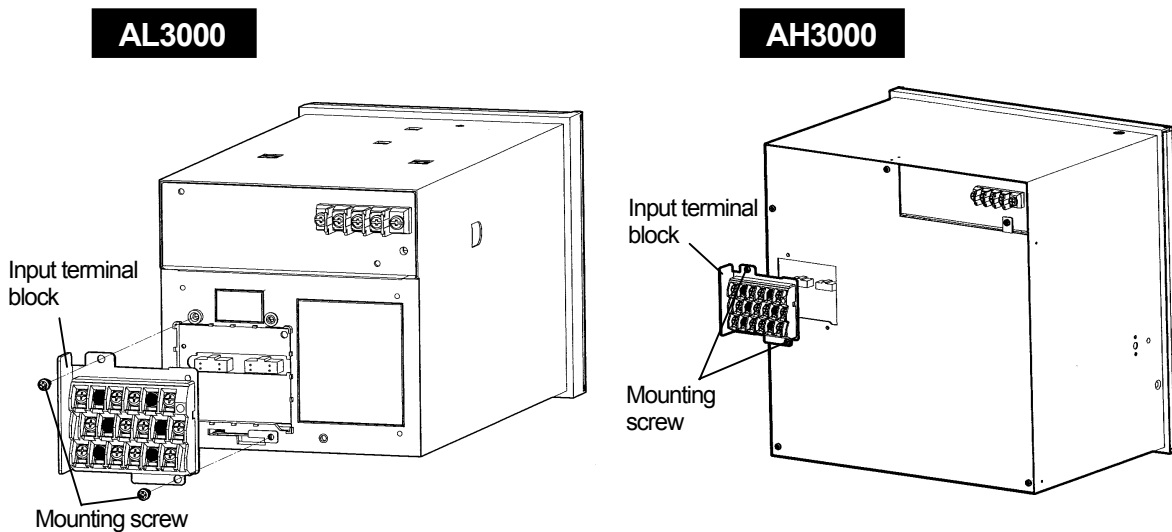

Remarks

Removed terminals have to be remounted to the recorder to which they were originally mounted. Mounting them to other recorders may cause a malfunction in scaling.

4. CONNECTIONS

4.2 Cautions on Connections

Observe the following cautions during connections for securing safety and reliability.

1 Power supply

Use a single-phase power supply having a stable voltage without any waveform distortion for the purpose of preventing wrong operations.

 **Warning** A switch and an overcurrent protective device

Prepare a switch and an overcurrent protective device (3 A) to the power supply for preventing an accidental electric shock during connection work. This instrument is not provided with any replaceable overcurrent protective device.

 **Warning** Turn off the power supply before starting connections.

Make sure to turn off the power supply before connecting the power and the input/output terminals to prevent an electric shock.

2 Keep the input/output connections away from high voltage power circuits

Don't place the input/output cables close to or in parallel with any strong power circuits including power lines. Place the cables 50cm or more away from high voltage power circuits when they are placed close to or in parallel to other circuits.

3 Keep the thermocouple input away from a heat source

For thermocouple inputs, keep the input terminals away from a heat source (a heating body) to reduce a reference junction compensation error. Don't expose the input terminals to direct sunlight, etc.

4 Keep the input/output connections away from noise source

Keep all connection cables away from noise source as far as possible, otherwise a malfunction may occur. Provide a solution if the cables cannot be separated from a noise source due to unavoidable circumstances.

Major noise sources	Remedial measures
Electromagnetic switch, etc. Power line having waveform distortion, Inverter, Thyristor regulator	Insert noise filters between power terminals and input/output terminals. A CR filter is often used.

5 Use crimp style terminals

- (1) Mount crimp style terminals for connection cable terminations to prevent any looseness or disconnection of terminals or a short-circuit failure between terminals.
- (2) Use the crimp style terminals with an insulation sleeve to prevent an electric shocks.

6 Unused terminals

Don't use any unused terminals for relaying, otherwise the electric circuits may be damaged.

 **Warning** Secure the connected cables properly.

Secure the connected cables so as not to allow them to be hooked by a person or a substance, otherwise the connections may be cut and disrupted, and may cause an electric shock or other accidents.

Reference

Kinds of terminals and termination

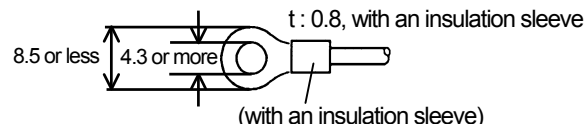
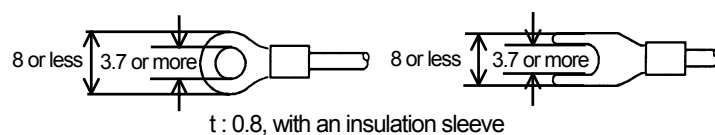
Terminal block	Screw diameter	Tightening torque	Termination (unit: mm)
Power and protective conductor terminals	M4	1.2N • m	 <p>(with an insulation sleeve)</p>
Terminals other than described above	M3.5	0.8N • m	 <p>*Use Type O chip (on the left) whenever possible.</p>

4. CONNECTIONS

4.3 Power Terminals

1 Power and protective conductor terminals

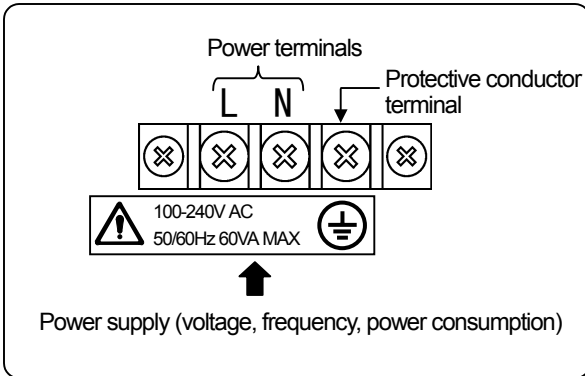

 **Warning** Turn off the power supply.

Make sure to turn off the power supply before the connections to the power and protective conductor terminals for preventing an electric shock.

Remarks L/N indication of power terminals

This indication conforms to the CSA standard, Canada. The live side of the single-phase AC power supply is indicated as L, and the neutral side is indicated as N. Observe the L and N connections for obtaining satisfactory performance.

2 Connection of power terminals

For connection to the power terminals, use a 600 V PVC insulated cable (IEC 227-3 See "Caution") terminated by the crimp style terminals with insulation sleeve.

Note) Use the cords approved by the following standards.

- (1) IEC 227-3
- (2) ANSI/UL817,
- (3) CSA C22.2 No.21/49

 **Caution** Be careful with the power voltage and noises.

The power voltage of your recorder is indicated beside the power terminals. Don't apply any voltage other than the rated voltage. Otherwise a malfunction may result. If noise is contaminated in the power supply, provide a noise reduction transformer, etc.

3 Connection of protective conductor terminal

Make sure to connect this terminal to the protective conductor of the power supply facility. For this connection, use a cable terminated by the crimp style terminals with insulation sleeve.

- Grounding wire: Copper wire 2 mm² or more

 **Warning**  mark at power terminals

A voltage of 100 to 240 VAC is applied to the power terminals after connections. Be sure to mount the power terminal cover to prevent an electric shock.

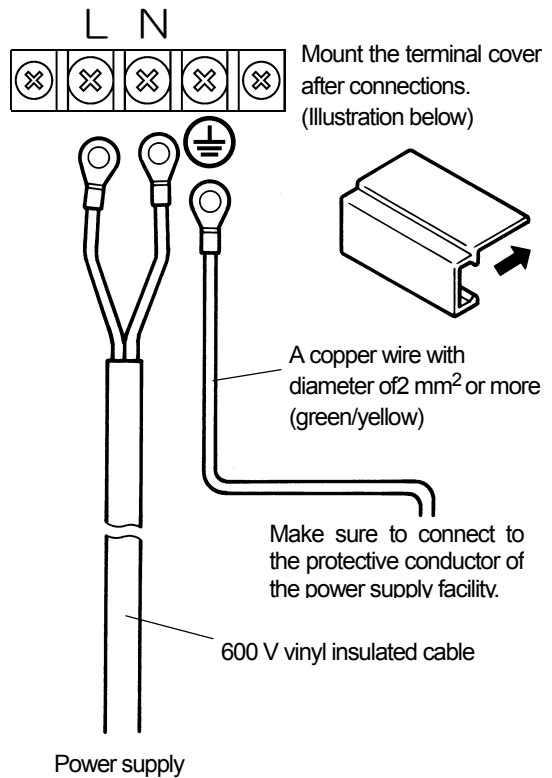

4. CONNECTIONS

4.4 Measuring Input Terminals



1 Measuring input terminals

Make sure to turn off the power supply to prevent an electric shock.

- (1) Measuring input terminals are located on the down left of the terminal board.
- (2) For the connections to the input terminals, use cables terminated by crimp style terminals with insulation sleeves.

Caution Allowable input voltage

Input type	Allowable input voltage
Voltage, Thermocouple input	± 10 VDC (range: ± 2 V or less) ± 60 VDC (range: ± 5 V or more)
Resistance thermometer input	± 6 VDC

2 Connections of DC voltage (current) input

Use twisted cables for instrumentation as the input cables for the purpose of suppressing noise. For current inputs, mount shunt resistors (Section 16.2) to the channels to be measured before connections.

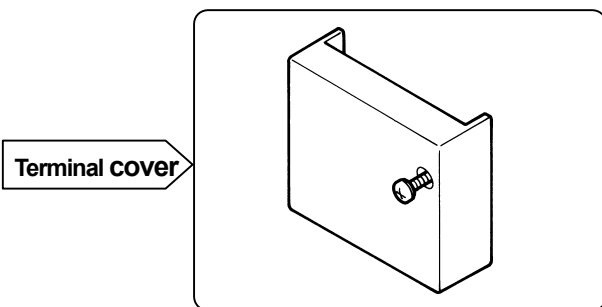
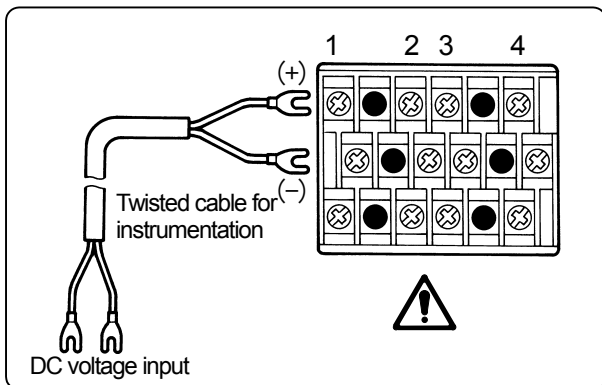

3 Connections of thermocouple inputs

Make sure to use thermocouple wires (or extension wires) to the input terminals of your recorder. If a copper wire is used halfway, a noticeable measuring error occurs. Don't use a pair of thermocouple wires in parallel with other instruments (controller, etc.), otherwise a malfunction may occur.

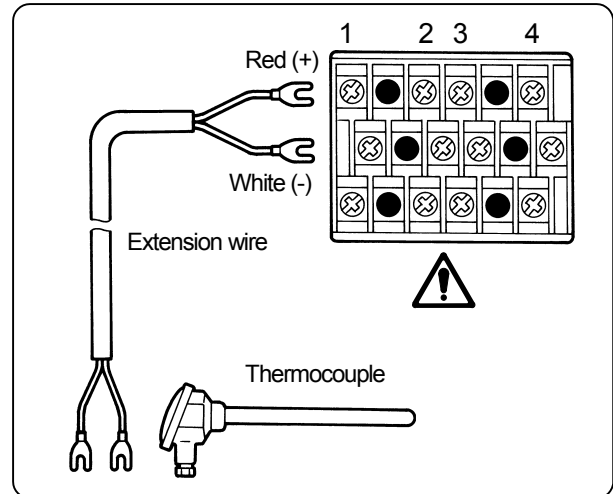

4 Connections of resistance thermometer inputs

Use a 3-core cable where each lead wire has an equal resistance value. Don't use one resistance thermometer in parallel with other instruments (controller, etc.).

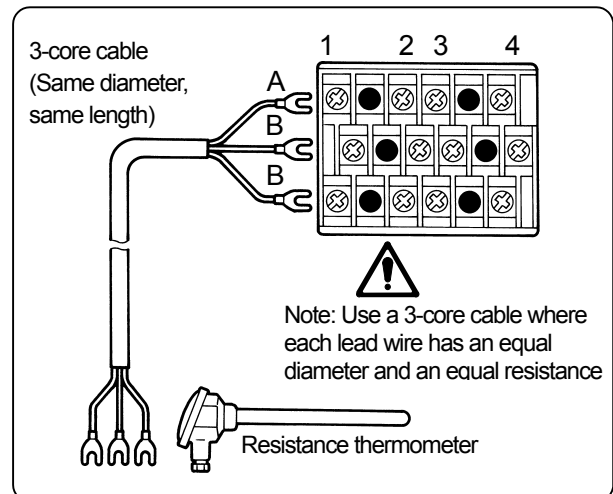

Warning mark of measuring input terminals

A high voltage may be applied to the measuring input terminals due to common mode noise. The allowable noise value is 30 VAC or less, or 60 VDC or less. Make sure that the noise is lower than the allowable value. Mount the terminal cover after connections for the purpose of preventing an electric shock and to protect the input wires. In the case of thermocouple input, the mounting of the terminal cover can reduce the reference junction compensation error.

4. CONNECTIONS

4.5 Alarm Output Terminals

These terminals are for the alarm output (option), which is (1) MOS relay type, (2) mechanical relay “c” contact type or (3) mechanical relay “a” contact type. The mechanical relay “c” contact type does not conform to the international safety standards.

1 Alarm output terminals

The terminal arrangement depends upon the type of alarm output.

Terminal and relay No.

Terminal block	AL3000	AH3000
1	No. 1 to 6	No. 1 to 6
2		No. 1 to 12

[Remarks] Only one terminal block is provided for the remote contacts terminals.

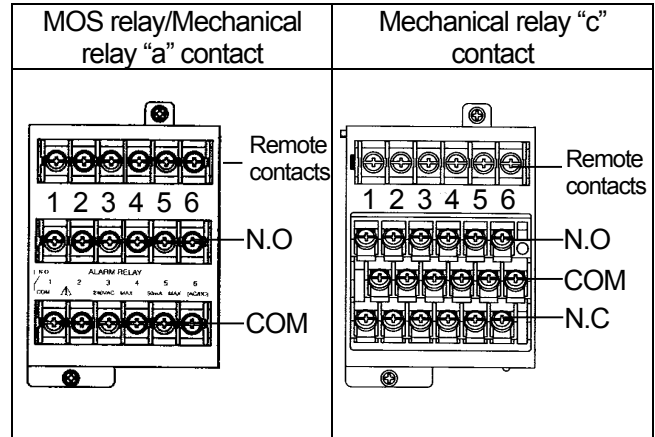

2 Connections

Turn off the power supply and buffer relay power supply before the connections for preventing an electric shock.

- Connect cables to a load via a buffer relay.
- Use cables with crimp style terminals and insulation sleeves for the alarm output terminals.

Caution Take safety measures.

The alarm output of your recorder may become defective. This may be caused by wrong operation, failure or other abnormal inputs. Take safety measures against an output failure before use if necessary.

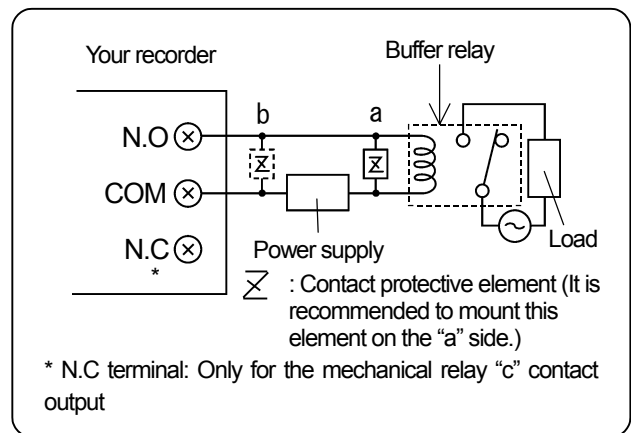

3 Cautions on connections

1) Output contact rating

(1) MOS relay

Maximum voltage	240 V (AC, DC)
Maximum current	50 mA (AC, DC)

(2) Mechanical relay

Power supply	Resistive load	Inductive load
100 VAC	0.5 A	0.2 A
240 V AC	0.2 A	0.1 A
100 V DC	0.3 A	0.1 A

Warning mark for alarm output terminals

A buffer relay power supply is applied to the alarm output terminals after connections. Don't touch these terminals for preventing an electric shock. Make sure to mount the terminal cover after connection.

2) Mounting of contact protective element

- Mount a contact protective element conforming to the buffer relay.
- To prevent a malfunction being caused by a light load, the most effective mounting position for the element is on the coil side of the buffer relay ('a' in the above diagrams)
- The MOS relay will be broken, even if a signal exceeding the contact rating is momentarily applied.

4. CONNECTIONS 4.6 Remote Contacts Terminals

These terminals are for the remote contacts (option). For the remote contacts, see Section 13.

1 Remote contacts terminals

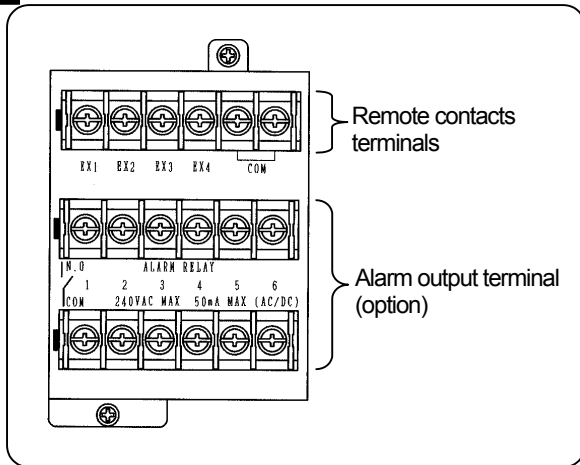

Warning No-voltage contacts

For the contacts to be connected to the remote contacts terminals, use a switch or relay driven at 30 VAC or lower, or 60 VDC or lower, or manual contacts for very light loads.

Remarks Remote contacts terminals

- Voltage when the contact is open: Approx. 5 V
- Current when the contact is short: Approx. 2 mA

2 Wiring

To prevent an electric shock, make sure to turn off the power supply before wirings.

- (1) The signals applied to the remote contacts terminals should be non-voltage contact signals.
- (2) Connect wires to the remote contacts terminals with crimp style terminals and insulation sleeves

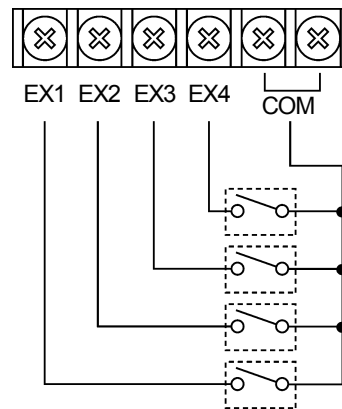

Reference Remote contacts

1. Remote contacts operations

- (1) Printing ON/OFF and chart speed selection from 3 speeds (Using 2 terminals EX1 and EX2)
- (2) Message (Nos. 1 to 5) selection and printing (Using all of 4 terminals EX1 to EX4)
- (3) Message (Nos. 1 and 2) selection and printing (Using 2 terminals EX3 and EX4)
- (4) Digital data printing *
- (5) List (Nos. 1 to 3) printing *
- (6) Operation record (Nos. A to D) printing *
- (7) "Totalizing" (option) reset *

* Using any one terminal.

2. Terminal allocation for operation

It is required to set operations to be allocated to each terminal (EX1 to EX4).

3. Operations to be set

- (1) Printing ON/OFF and chart speed selection from 3 speeds
⇒ Setting of 3 chart speeds
- (2) Message selection and printing
⇒ Setting of messages Nos. 1 to 5
- (3) Operation recording
⇒ Setting of recording positions of operation records Nos. A to D

4. CONNECTIONS 4.7 Communications terminals

These terminals are for the communications interface (option). For details of the connection, refer to the instruction manual for the "Communications Interfaces" provided separately.

1 Communications terminals

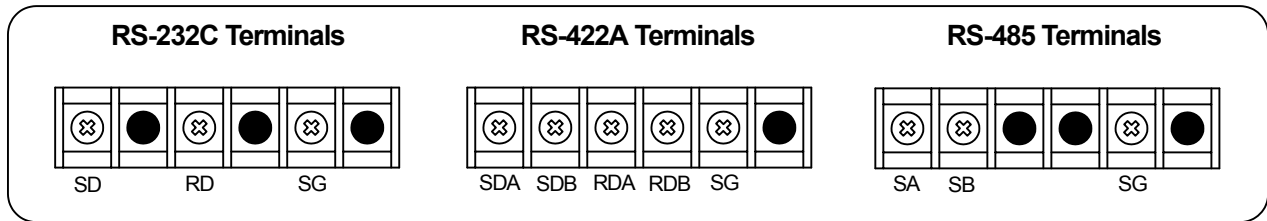

2 RS-232C Connections

When your recorder is with the communications interface of RS-232C, three terminals of SD, RD and SG are used but any control signal is not used. General personal computers are controlled by control signal. Wiring processing for control signal in a connector depends upon how the control signal is used in a personal computer. For details, refer to the instruction manual for your personal computer.

1) 9-pin connector

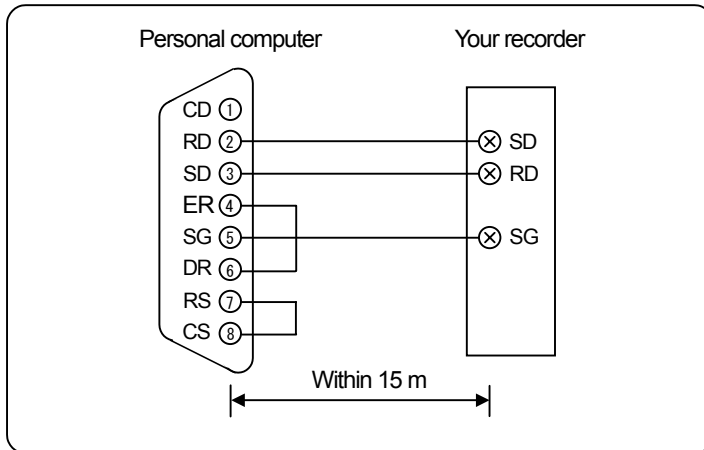

2) 25-pin connector

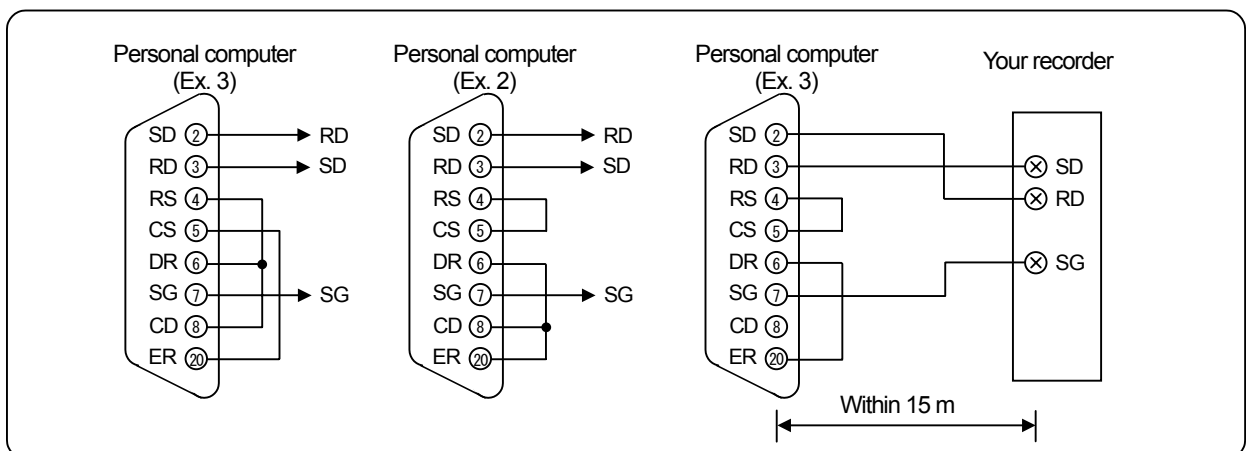

4. CONNECTIONS | 4.7 Communications terminals

3 RS-422A, RS-485 Connections

RS-422/485 communications interface is connected to a personal computer via a line converter (our Model SC8-10: sold separately). Three signals of SD, RD and SG are used between the line converter and the personal computer but any control signal is not used. Wiring processing for control signal in a connector is necessary in the same as RS-232C connections.

1) RS-422A

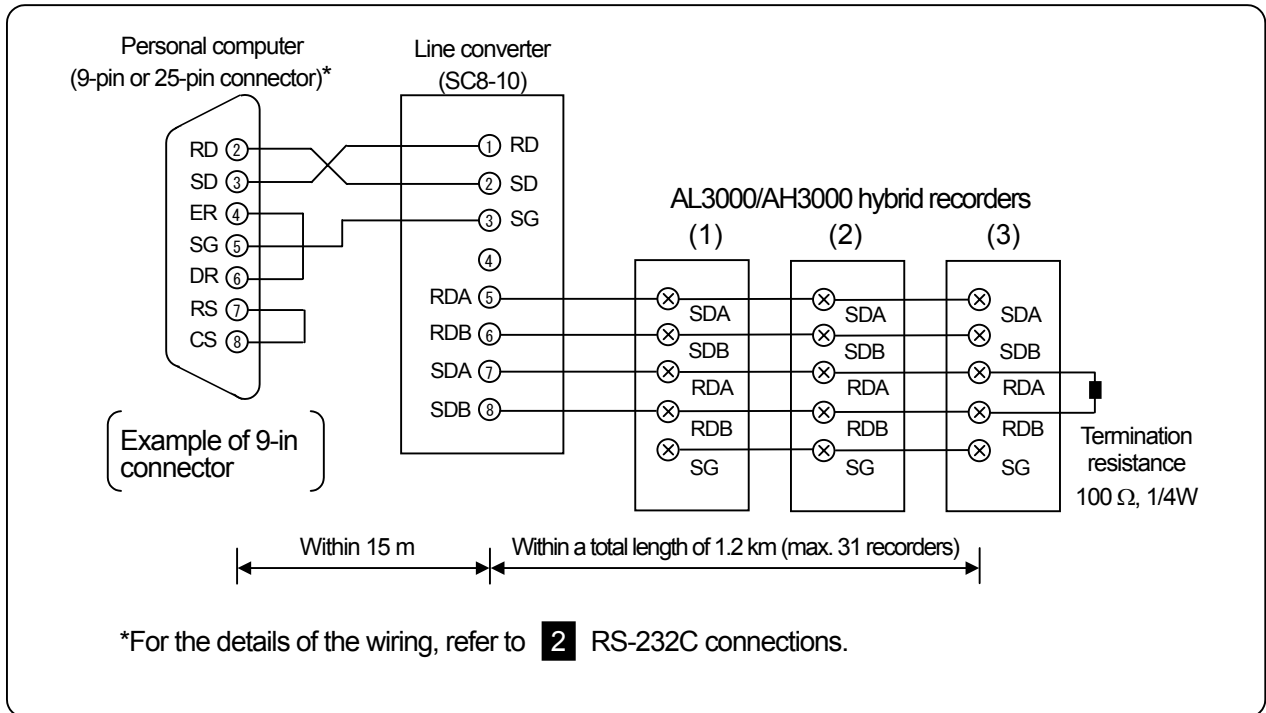

2) RS-485

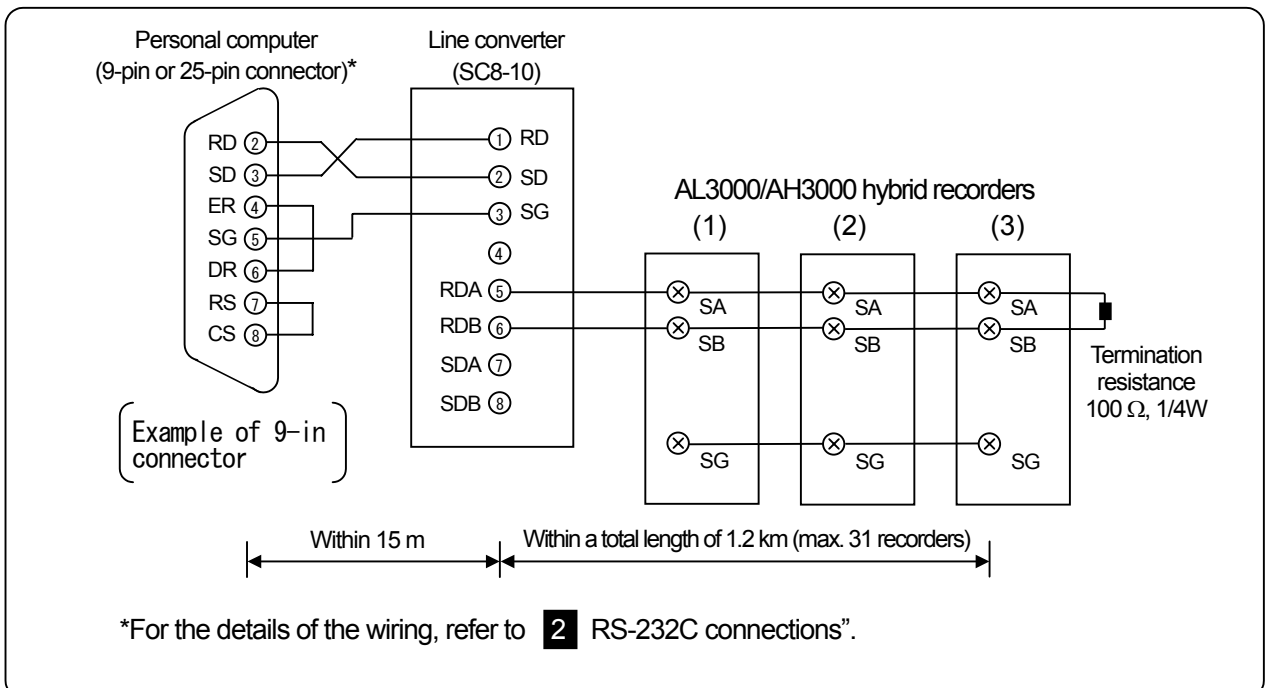

5. INSTALLATION

5.1 Chart Paper Loading (AL3000)

1 Chart Paper Cassette Removal

1) Open the door.

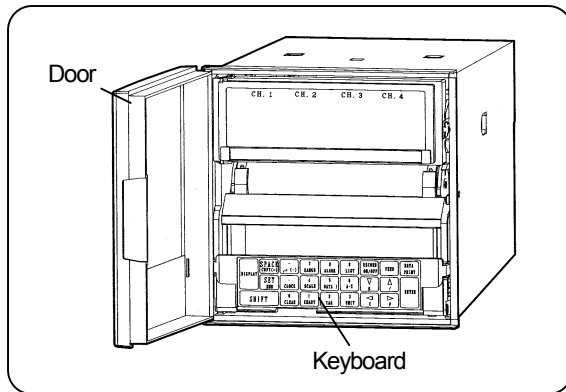

2) Swing down the keyboard.

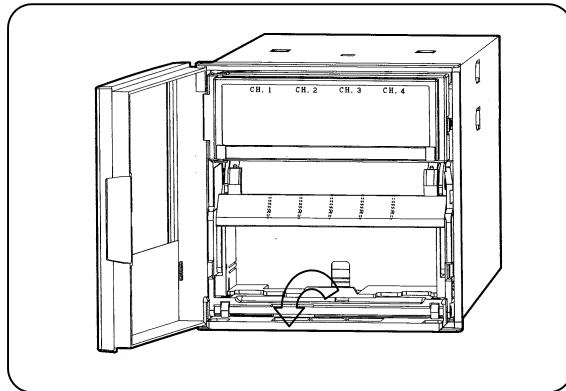

3) Remove the chart paper cassette.

Pens lift up when the chart paper cassette is removed.

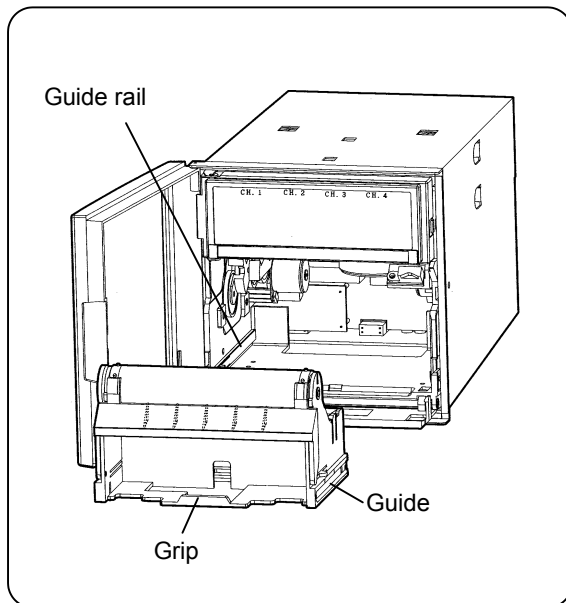

2 Chart Paper Loading

1) Open the chart paper holders.

Open the chart paper guide and the stripper plate.

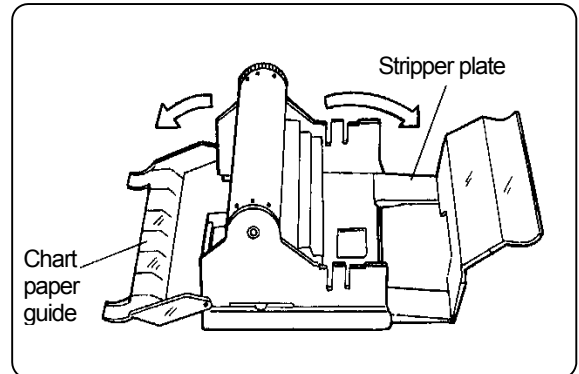

2) Prepare a chart paper

Shuffle both end of the chart paper to prevent two or more chart papers from fed being together.

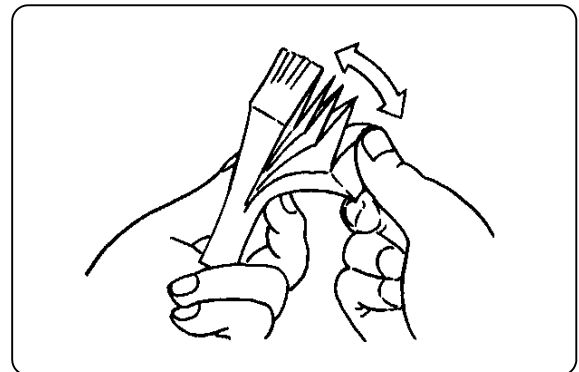

3) Put it into the chart paper housing.

The shapes of the sprocket holes on the right and left sides are different. The right side holes are an elliptical shape.

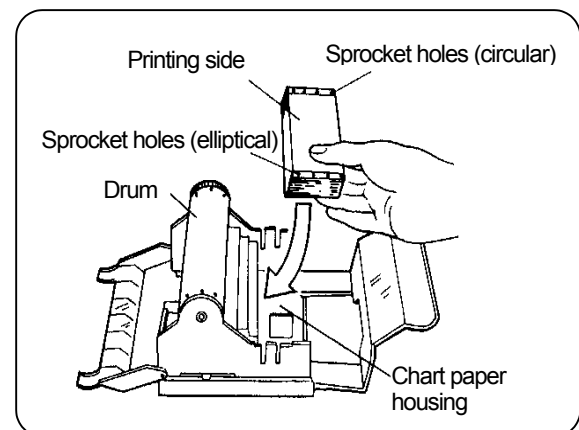

5. INSTALLATION

5.1 Chart Paper Loading (AL3000)

3 Chart Paper Setting

- 1) Draw out the chart paper approx. 20 cm and close the rear stripper plate.
- 2) Set the holes on the chart paper over the sprockets at both ends of the drum.
- 3) Use the thumb wheel to advance the chart paper for 2 to 3 folds into the chart tray.
- 4) Close the front chart paper guide. Make sure that the holes are set over the sprockets.

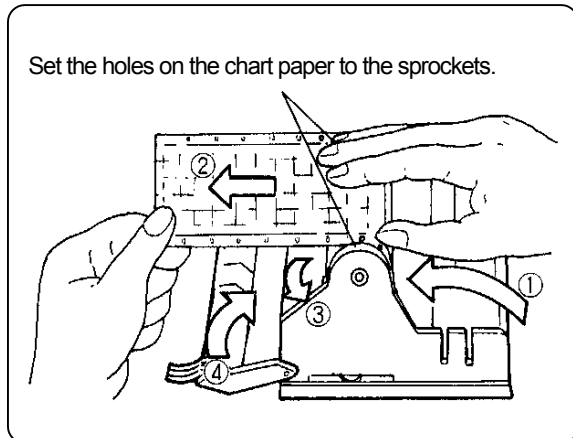

Remarks

Chart paper folds

Don't insert the chart paper folds reversely when inserting the chart paper into the chart paper tray, otherwise a folding failure results.

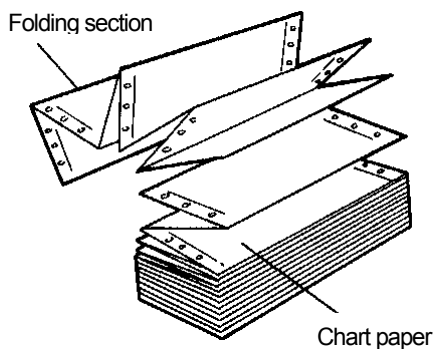

4 Check

- 1) Manual check
Turn the thumb wheel by hand to make sure that the chart paper is feeding properly.

Remarks

Turning direction of thumb wheel

Don't turn the thumb wheel inward. The chart paper cannot be fed backward. This action may cause a chart paper feed failure.

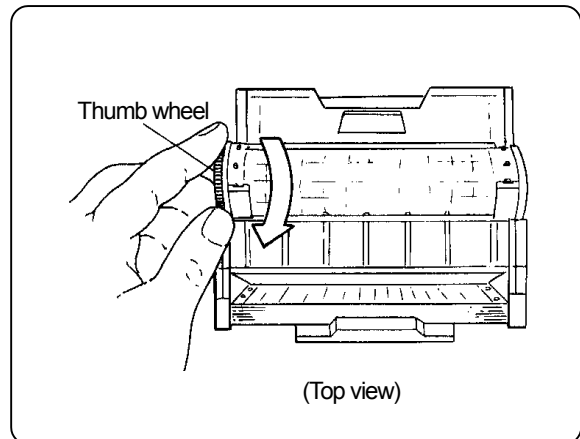

- 2) Place the chart paper cassette in its original position

Place the chart paper cassette with the chart paper loaded in your recorder.

- (1) Guide rails for the chart paper cassette are located on the right and left side of the internal unit. Set the guides of the chart paper cassette to the guide rails and push it until it clicks into place.
- (2) Return the keyboard back in its original position.

- 3) Chart paper feeding check

- (1) Turn on the power supply.
- (2) Press the **FEED** key and check the chart paper feeds smoothly.
- (3) Repeat the above procedure if the chart paper is not fed smoothly.

- 4) Operation during chart end detection

When the chart paper cassette is returned in the internal unit during the chart end detection, the **CHART END** display blinks. Press **ENTRY** to turn it from blinking to steady lighting.

Press **ENTRY** again. The **CHART END** display goes out and the chart paper is fed automatically.

5. INSTALLATION

5.2 Chart Paper Loading (AH3000)

1 Chart Paper Cassette Removal

1) Open the door.

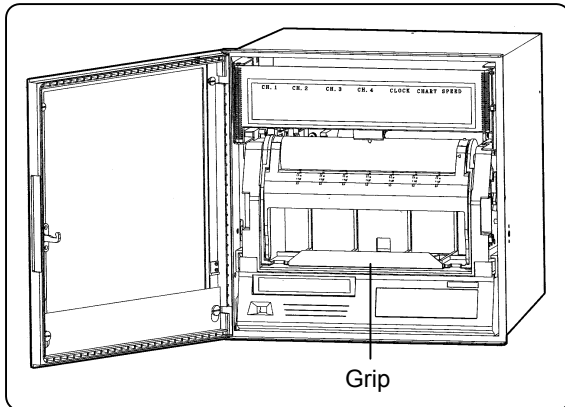

2) Remove the chart paper cassette.

- (1) Pull the grip of the chart paper cassette and take the chart paper cassette slightly out of the internal unit. (Pens lift up.)
- (2) Pull the grip slowly to take the chart paper cassette out of the internal unit completely.

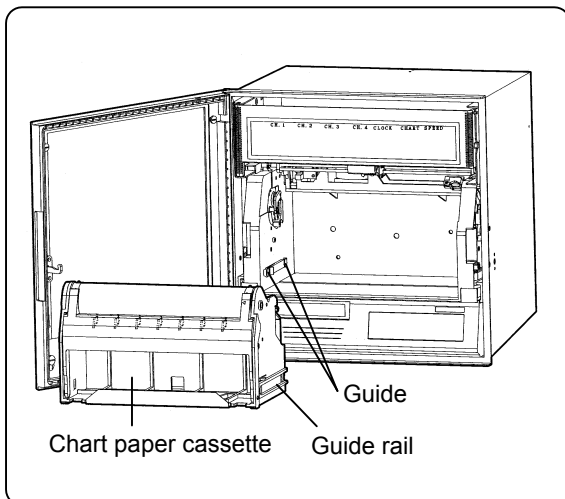

 **Caution** Be careful with the corners of the rear stripper plate

The sharp corners of the rear stripper plate help to feed the chart paper smoothly. Be careful not to cut your fingers when loading or replacing the chart paper.

 **Caution** Don't remove the chart paper cassette during printing.

Don't remove the chart paper cassette during printing by a plotter pen. The cassette may hit 1st pen during the automatic pen lift-up function executed.

2 Chart Paper Loading

1) Open the chart paper holders.

Open the chart paper guide and the stripper plate.

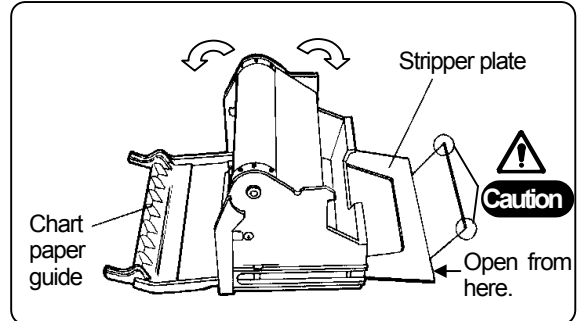

2) Prepare a chart paper.

Shuffle both end of the chart paper to prevent two or more chart papers fed being together.

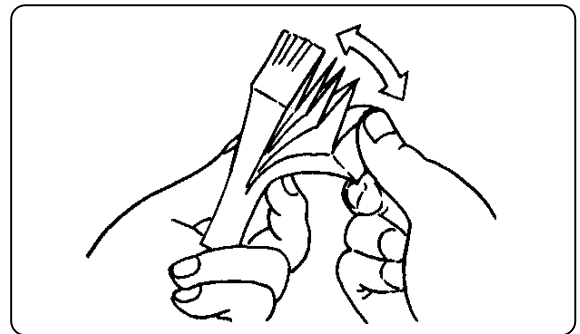

3) Put it into the chart paper housing.

The shapes of the sprocket holes on the right and left sides are different. The right side holes are an elliptical shape.

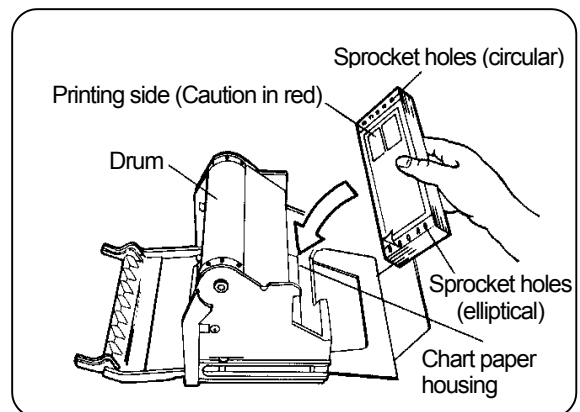

5. INSTALLATION

5.2 Chart Paper Loading (AH3000)

3 Chart Paper Setting

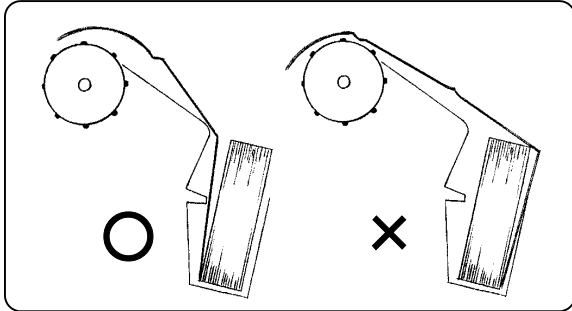

- 1) Draw out the chart paper approx. 50 cm and close the rear stripper plate.
- 2) Set the holes on chart paper over the sprockets at both ends of the drum.
- 3) Use the thumb wheel to advance the chart paper for 2 to 3 folds into the chart tray.
- 4) Close the front chart paper guide. Make sure that the holes are set over the sprockets.

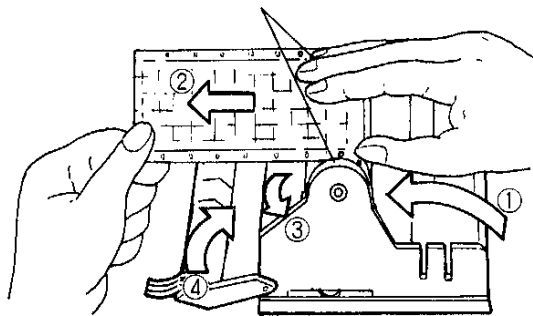

Set the holes of the chart paper on the sprockets.



Remarks Chart paper folds

The  mark for fold thread parts and the  mark for fold valley parts are printed on both ends of the chart paper.

Don't insert the chart paper folds the wrong way when inserting the chart paper into the chart paper tray, otherwise a folding failure will result.

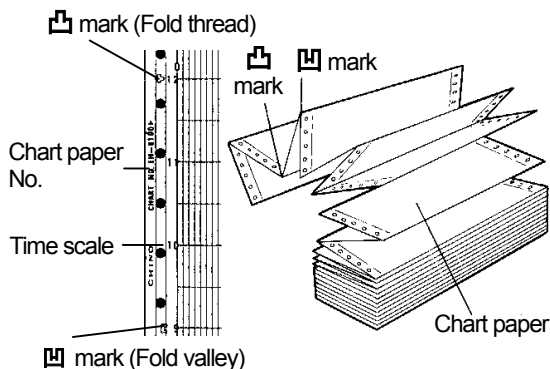

4 Check

- 1) Manual check

Turn the thumb wheel by hand to make sure that the chart paper is feeding properly.

Remarks Turning direction of the thumb wheel

Don't turn the thumb wheel inward. The chart paper cannot be fed backward. This action may cause a chart feed failure.

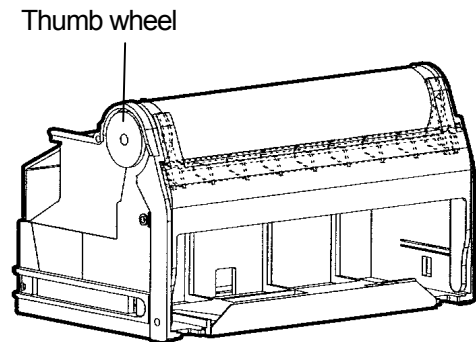

- 2) Place the chart paper cassette in its the original position

Guide rails for the chart paper cassette are located on the right and left side of the internal unit. Set the guides of the chart paper cassette to the guide rails and push it until it clicks into place.

- 3) Chart paper feeding check

- (1) Turn on the power supply.
- (2) Press the **FEED** key and check that chart paper feeds smoothly.
- (3) Repeat the above procedure if the chart paper is not fed smoothly.

- 4) Operation during chart paper end detection

When the chart paper cassette is returned in the internal unit during the chart end detection, the **CHART END** display blinks. Press **ENTRY** to turn it from blinking to steady lighting.

Press **ENTRY** again. The **CHART END** display goes out and the chart paper is fed automatically.

5. INSTALLATION

5.3 Recording Pen Loading

1 Recording Pen Types

- (1) There are two types of recording pens, the plotter pens for use in digital printing and cartridge pen for use in trace printing.
- (2) There are four kinds of cartridge pens for 1st pen to 4th pen. These are of same shape but differ in ink colors.

1 st pen: Red	3 rd pen: Blue
2 nd pen: Green	4 th pen: Brown

2 Preparation for Installation

- 1) To remove the chart paper cassette
 - AL3000 → See Section 5.1.1.
 - AH3000 → See Section 5.2.1.
- 2) Open the display panel.
Swing out the panel from the right edge.
- 3) Set to the pen replacement mode.
 - (1) Turn on the power supply.
 - (2) If the status **RECORD ON** lights, go it out by pressing **REC ON/OFF** and then **ENTRY**. (Pens lift up.)
 - (3) Press and hold **REC ON/OFF** down for 3 seconds. The pens return to original positions and then move to the center.
 - (4) Each press of **ENTRY** moves each pen to the "zero" position. Replace each pen at its "zero" position.

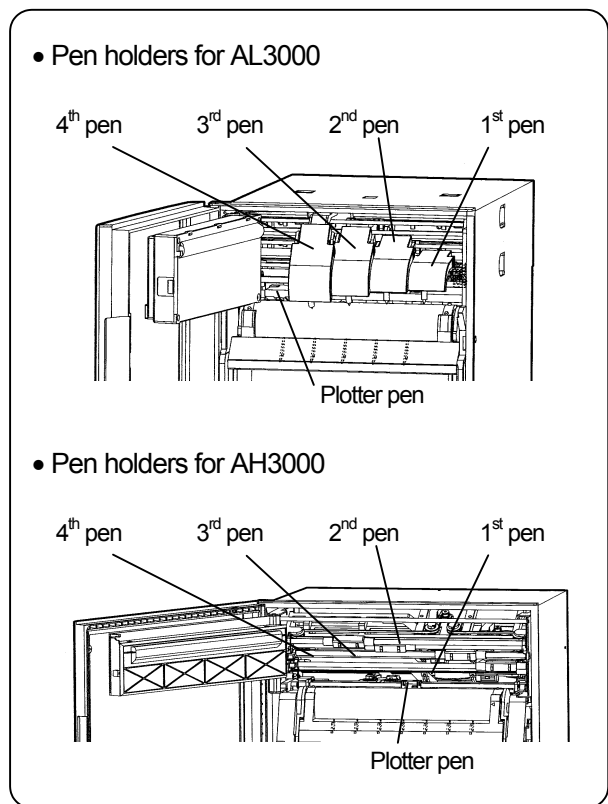
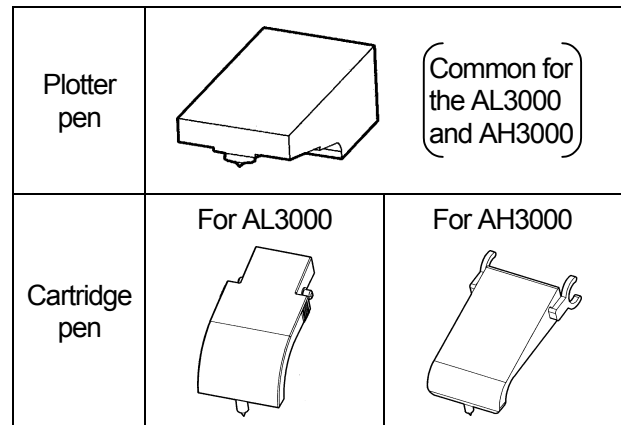

Remarks

Maintenance of pens

1. Pen tip

The pen tip is made of felt material. If an excessive force is added to it, the top of the pen tip will be crushed making clear printing or tracing impossible.

2. Pen cap

Each pen is provided with a pen cap for preventing drying and protecting the pen tip. Remove and retain the pen caps before the pen installation.

3. Before stopping recording for long hours

When it is expected that recording will not be executed for a day or more, remove and store the pens by attaching the pen cap to them. If the pens are left installed while no recording is executed, the ink will stain the chart paper.

5. INSTALLATION

5.3 Recording Pen Loading

3 Plotter Pen Loading

- (1) Before loading, remove the pen cap from the plotter pen and write letters on a paper, etc. for testing.
- (2) Insert the plotter pen into its penholder completely.
(Note) Incomplete insertion may result in recording troubles.
- (3) For unloading of the plotter pen, pull it from the penholder.

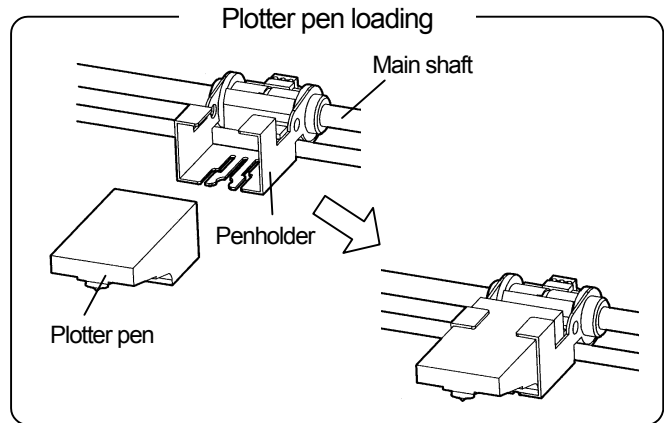

4 Cartridge Pen Loading

- (1) Before loading, remove the pen cap from the cartridge pen and write letters on a paper, etc. for testing.
- (2) Push the cartridge pen into the penholder for the same pen No. as the pen.

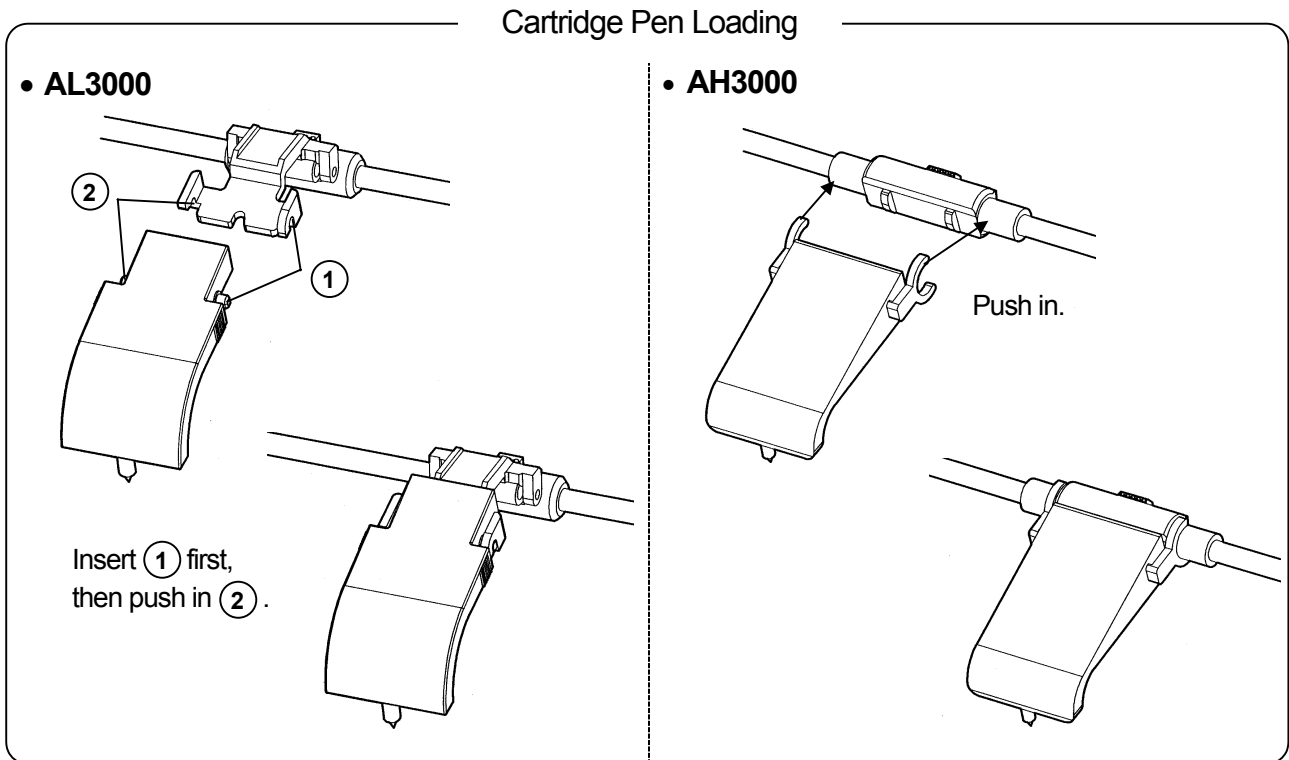

- (3) For unloading of the cartridge pen,
 - AL3000: Pull out the left side of the pen from the holder, and then take off it by disengage its convex part at the right side of the holder.
 - AH3000: Pull the pen from the holder.

6. BASIC OPERATION 6.1 Power Supply and Operation

1 Power Supply On/Off

Your recorder is not provided with a power switch. Prepare an external power switch for turning on or off its power supply.

2 Initial Operation

By turning on the power supply, 1) year, month and day are displayed. After initialization, 2) year, month, day and time are printed (Printing when the power is turned on) and 3) the normal operation starts.

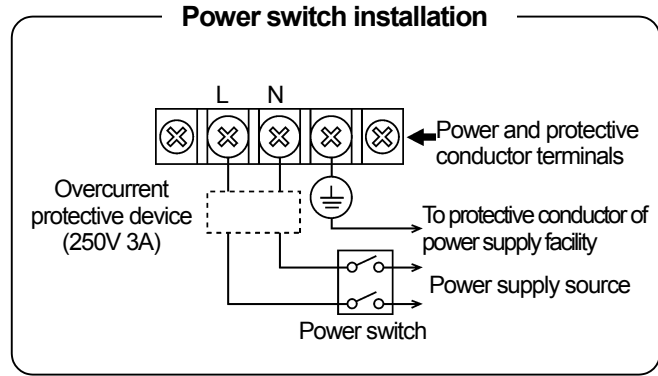

3 Operation

1) Operation screen

- (1) Measured values for all channels (CH 1 to 4: depending on the numbers of input points) are digitally displayed.
- (2) Measured values for all channels (CH 1 to 4: depending on the numbers of input points) are displayed by bargraphs.
- (3) A corresponding status lamp lights. The default is **RECORD ON**.

Example of operation screen (3-pen type)

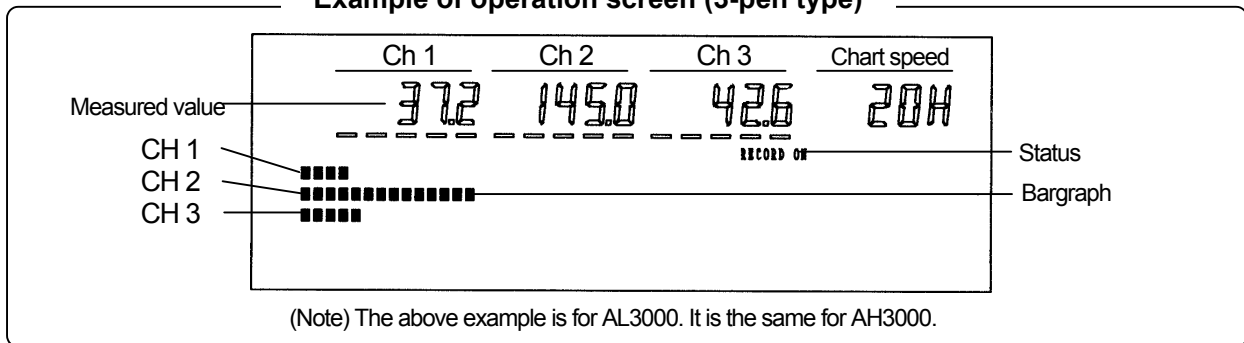

2) Chart paper feeding

The chart paper is fed at the programmed chart paper speed. (The default speed is 20 mm/h for AL3000 and 25 mm/h for AH3000.)

3) Printing

(1) Trace printing

Measured values are traced by a cartridge pen.

<Ink colors> CH 1: Red, CH 2: Green, CH 3: Blue, CH 4: Brown

(2) Digital data printing

a. Fixed-time printing

The following data is printed at preset time intervals.

- Time line
- Time
- Year/Month/Day
- Chart speed
- Scale
- Engineering unit
- Tag

b. Other printings

The following printings are executed according to programming and operation.

- Periodic data printing
- Digital data printing
- List 1, 2 and 3
- Programming change mark
- Alarm activation/reset
- Message
- Operation printing line and No.
- Time axis synchronization mark

Trace printing and fixed-time printing

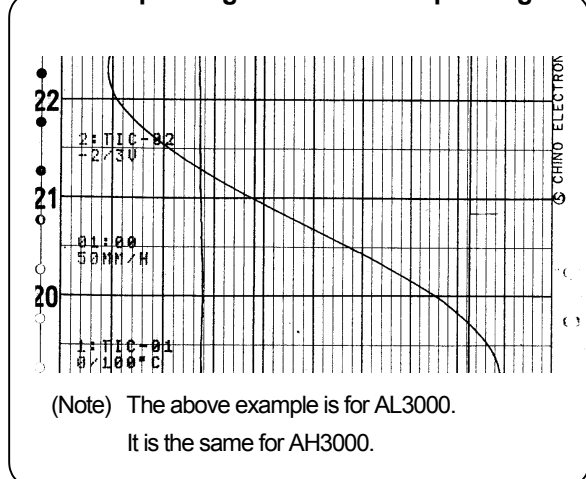

6. BASIC OPERATION

6.2 Printing ON/OFF and chart end detection

1 Printing On/Off

Every time pressing **REC ON/OFF** then **ENTRY** within 5 sec., the printing function switches to on or off.

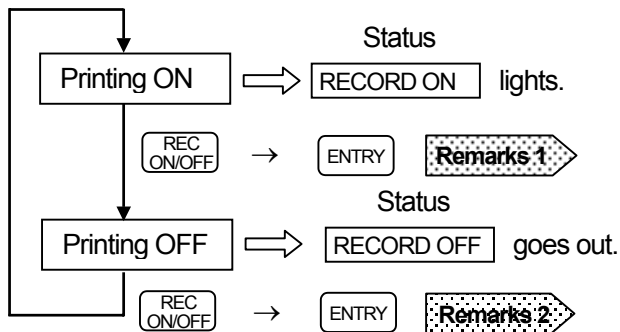

Reference 1 Printing status when turning on the power supply

When turning on the power supply, the printing maintains the condition (on or off) when it was turned off last time.

Reference 2 Up and down of pens

- (1) When the printing is turned off, each pen lifts up automatically. Even if the power is turned off in this condition, this pen position is maintained.
- (2) When the chart cassette is pulled out, each pen lifts up. If the printing has been turned off when pulling out the chart cassette, each pen has already been lifted up and it maintains its position.

Status display when printing is on

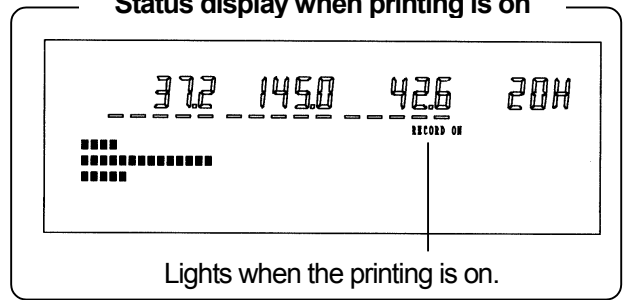

Remarks 1 No printing on/off operation executed

- (1) The printing on/off operation is not executed when the status **KEY LOCK** lights. For its cancellation, see Section 11.13.
- (2) The printing on/off operation is not executed when the printing is turned off by the remote contacts signal (option). See Section 13.1.

Remarks 2 Execution by pressing **ENTRY** key

- (1) **PUSH ENTRY** appears for about 5 sec. when pressing **REC ON/OFF** key. Press **ENTRY** during this display to execute the printing on/off operation.
- (2) The printing on/off operation cannot be executed by pressing **ENTRY** after this display goes out.
In such case, press **REC ON/OFF** and then **ENTRY** again.

2 Printing Operation

The table below explains the printing operation when the printing is on or off.

Operation	ON	OFF
Chart feeding	Execute	Stop
Trace printing (Cartridge pen)	Execute	Up where it is
Digital data printing (Plotter pen)	Execute	Up at standby position
Up and down of pens	Down	Up

3 Chart End Detection

When the chart end is detected during the printing is on, the printing is switched to off and **CHART END** blinks. Each pen lifts up automatically and the printing is stopped. For continuing the printing, refer to "Chart loading" in Section 5.1 and 5.2.

6. BASIC OPERATION | 6.3 Fast Feeding of Chart Paper

When pressing **FEED**, chart is fed at the speed of about 0.1mm/sec. When pressing **FEED** more than 1 sec, chart is fed at the speed of about 10mm/sec. This operation is used for the following purposes.

- (1) Setting the time scale line of the chart paper
- (2) Checking of chart paper feeding operation

Remarks Fast feeding condition and operation

1. Condition (1) For the fast feeding of the chart paper, the status **KEY LOCK** should be gone out.
(2) This function cannot be executed during printing.
2. Operation Digital data printing is not executed during the fast feeding of the chart paper.
This function can be executed when the printing is off (**RECORD ON** goes out.).

Reference 1 Manual chart feeding

Pull out the chart paper cassette slightly from your recorder. Turn the thumb wheel on the left side of the drum.

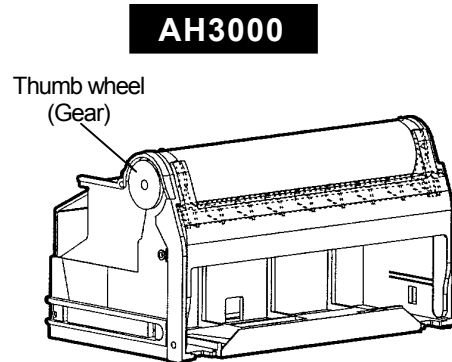
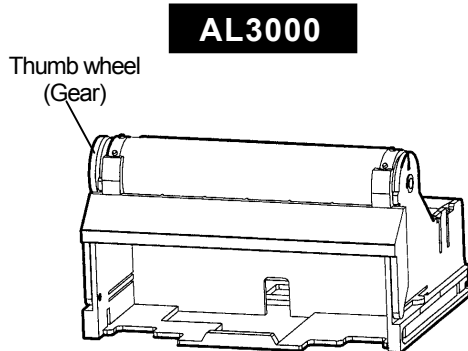

Note: Even if the time scale line is set by manual chart paper feeding, a delay may occur due to the back lash of the thumb wheel (gear).

Remarks 2 Time scale (1 to 24)

Numeric values of 1 to 24 are marked on the left side of the chart paper. These are time scales when operating the printing at a chart speed of 20 mm/h for AL3000 or 25mm/h for AH3000.

6. BASIC OPERATION 6.4 Switching Operation Screen (AL3000)

For AL3000, three operation screens, (1) measured value screen, (2) clock screen and (3) alarm activation screen, are available. Each time **DISP** is pressed, the screen switches. Bargraphs for analog indications are displayed in any of these screens.

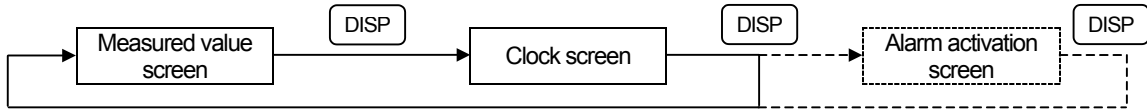

(Note) The alarm activation screen is only available when an alarm activates (shown by dotted lines). When no alarm activates, this screen is skipped.

1 Measured value screen

The screen differs on Model No. (number of pens).

1) 1-pen type (CH 1)

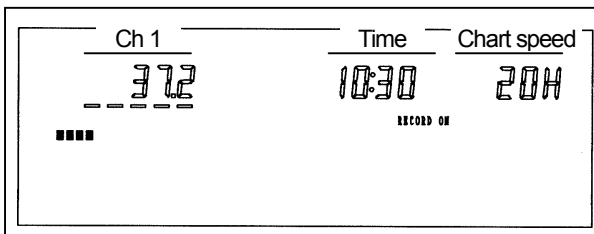

2) 2-pen type (CH 1 and 2)

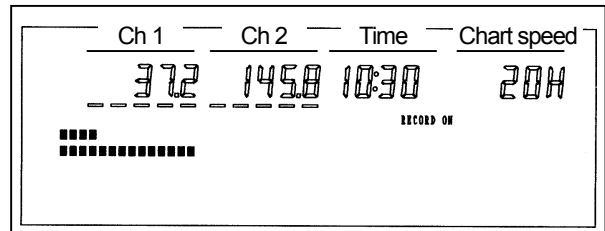

3) 3-pen type (CH 1 to 3)

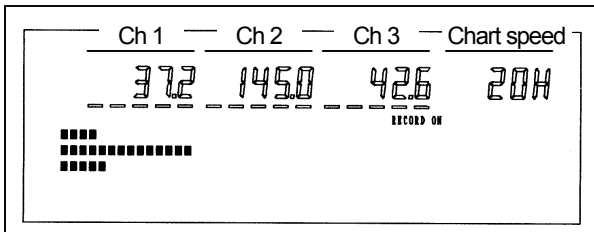

4) 4-pen type (CH 1 to 4)

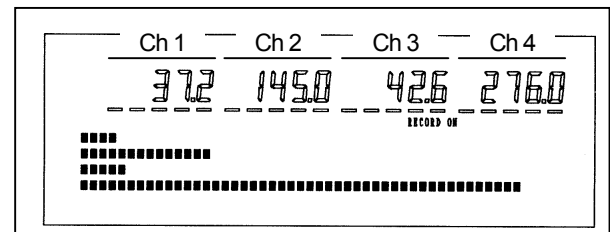

2 Clock screen

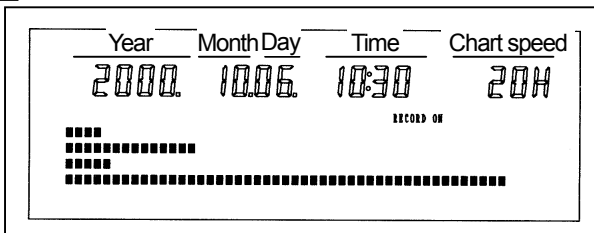

Reference Screen when turning on the power supply

When the power supply is turned on, the measured value screen appears.

3 Alarm activation screen

This screen is only available when an alarm activates.

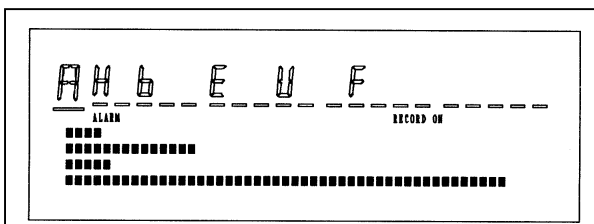

Explanation for alarm activation

In each channel, the alarm level 1, 2, 3 and 4 are allocated to the digits from the left end. The alarm type shall be displayed only at the digit where an alarm activates.

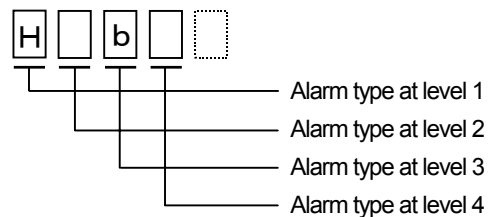

For alarm types, see Section 11.5, item **1**.

6. BASIC OPERATION

6.5 Switching Operation Screen (AH3000)

For AH3000, two operation screens, (1) measured value screen and (2) alarm activation screen, are available. Each time **DISP** is pressed, the screen switches. Bargraphs for analog indications are displayed in any of these screens.

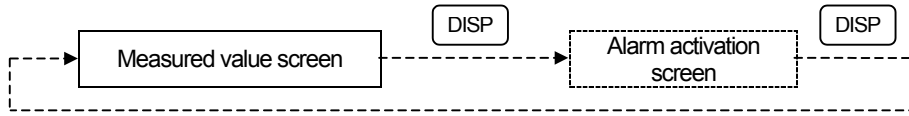

(Note) The alarm activation screen is only available when an alarm activates (shown by dotted lines). When no alarm activates, the measured value screen only appears even if **DISP** is pressed.

1 Measured value screen

The screen below is for 4-pen type. 1-pen type - measured value is displayed in CH 1. 2-pen type - measured values are displayed in CH 1 and CH 2. 3-pen type - measured values are displayed in CH 1 to CH 3.

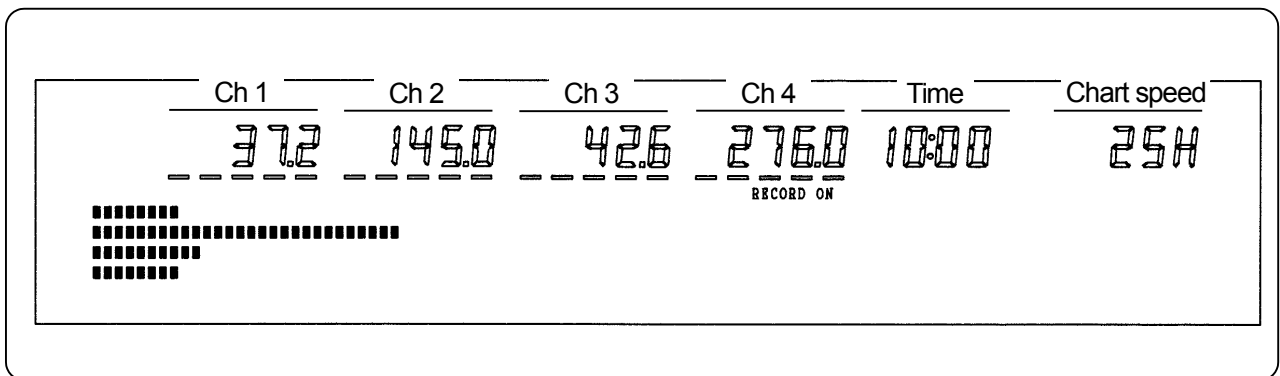

2 Alarm activation screen

This screen is only available when an alarm activates.

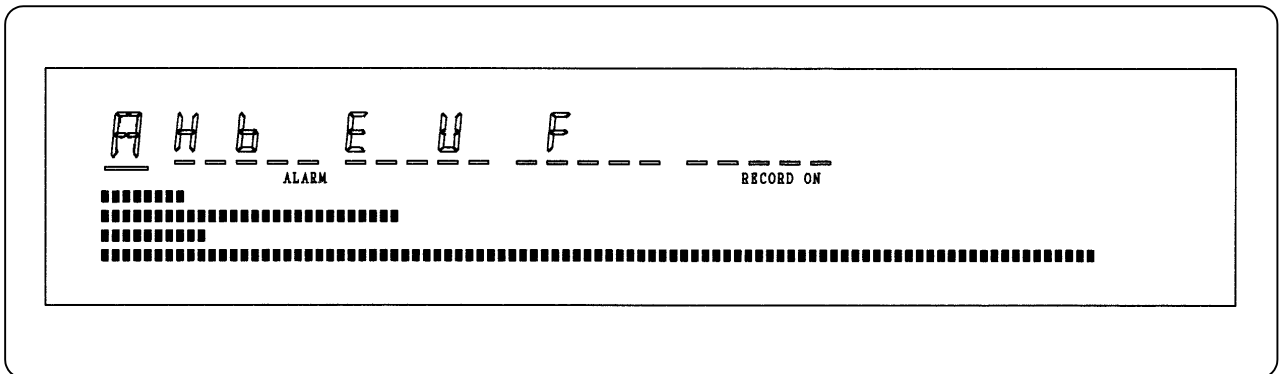

Explanation for the display

In each channel, the alarm level 1, 2, 3 and 4 are allocated to the digits from the left end. The alarm type shall be displayed only at the digit where an alarm activates.

For alarm types, see Section 11.5, item **1**.

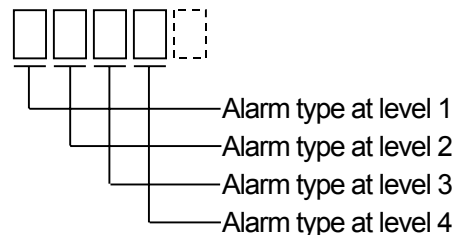

7. PROGRAMMING

7.1 Keys and Characters

1 Keys and Their Abbreviations

Actual keys										Key abbreviations used in this manual											
DISPLAY RECORD FORMAT	SPACE COPY(=)	←(←)	7 RANGE	8 ALARM	9 LIST	RECORD ON/OFF	FEED	DATA PRINT			DISP	SPACE COPY(=)	←(←)	7 RANGE	8 ALARM	9 LIST	REC ON/OFF	FEED	DATA PRINT		
SET END	• CLOCK	4 SCALE	5 DATA I	6 A~Z	▼ %	▲ /					SET END	• CLOCK	4 SCALE	5 DATA I	6 A~Z	▼ %	▲ /				
SHIFT	0 CLEAR	1 CHART	2 TAG	3 UNIT	◀ °C	▶ °F					SHIFT	0 CLEAR	1 CHART	2 TAG	3 UNIT	◀ °C	▶ °F				ENTRY

2 Characters Displayed in Programming

Except for the leftmost digit, characters including alphabets are displayed as shown below due to the restriction with 7-segment LCD.

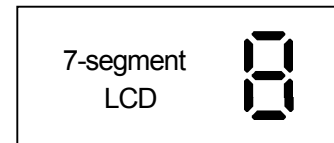

A	B	C	D	E	F	G	H	I	J	L	L	M	N	O
A	b	C	d	E	F	G	H	,	U	A	L	ā	n	o

P	Q	R	S	T	U	V	W	X	Y	Z				
P	/	r	S	t	U	U	U	/	Y	≡				

1	2	3	4	5	6	7	8	9	0	Space	Minus	Hyphen	Colon	To
1	2	3	4	5	6	7	8	9	0		-	-	:	↗

3 Key Operation

Remarks Don't press keys with hard and sharp objects

The keys are composed of sheet switches containing electrical circuitry inside. If a key is pressed with a hard and sharp object, malfunctions due to wire disconnection or insulation breakdown may occur.

Press a single key.	Press two keys simultaneously.	Press two keys simultaneously for 3 sec. or longer
<p><Example> To program "6":</p>	<p><Example> To program an alphabet letter:</p> <p>Press (SHIFT) key first.</p> <p>0.5 sec.*</p>	<p><Example> To move the "Engineering" programming mode:</p> <p>Press (SHIFT) key first.</p> <p>3 sec. or more</p>

*Press the key for about 0.5 sec. and release it as soon as the display changes. If another screen appears by holding the key down for 3 sec. or more, press **DISP** to return to the original screen and press the key for about 0.5 sec. again

7. PROGRAMMING

7.2 Key Functions

1 Functions by Pressing Single Key

Keys	Names	Functions	
	Display	Stops programming and returns to the operation screen. For certain programming items, holding this key down for 2 seconds or more is required.	
	Space	(1) Deletes a numeric value or decimal point at an unnecessary digit. (2) Programs "Blank" in the programming of [engineering unit] or [tag].	
	Program	Changes from programming mode (confirmation of parameters) to the programmable condition. The programming lamp lights and the cursor appears at the programmable leftmost digit.	
	Shift	Press this key first for using the key functions being indicated on the lower case of each key.	
 	Minus Decimal point 0 to 9	Numeric values (1) Press these keys for programming a numeric value. (2) For programming a decimal point, move the cursor to the next digit and press before entering a numeric value. (3) For deleting a decimal point, move the cursor to the next digit and press .	
	Up		(1) For items to program by selecting from menu, this key steps the menu forward or backward.
	Down		(2) For items to program parameters per channel in the programming mode (confirmation of parameters), this key steps the channel No. forward or backward.
	Left cursor		Moves the cursor leftward.
	Right cursor		Moves the cursor rightward.
	Entry	(1) Programming items common to channels: Stores the programmed parameter into memory. (2) Programming items per channel: Stores temporarily the programmed parameter in the channel No. selected. Press + to store it into memory. (3) Printing on/off, data printing or list printing is executed by pressing this key.	
	Printing on/off	Selects on (enable) or off (disable) of printing. Press to go this selection active.	
	Feeding	The chart paper is fast fed when holding this key down.	
	Data print	Prints the measured values at the moment the key is pressed digitally on the trace printing. Press to go this printing active.	



2 Functions by Pressing Two Keys Simultaneously

Keys	Names	Functions
+	End	Stores the programmed parameter, which is temporarily stored, into memory.
+	To	Inserts [~ (r')] between minimum and maximum values.
+	Clear	Clears (Blanks) the programmed parameter displayed.
+	Alphabetic characters	Each time is pressed, characters step in the order of A, B, C
+	List printing	Programmed parameters are printed as a list. Press to go this printing active.
+	%	Programs "%" (percent) character.
+	/ (=)	Programs "/" (slash) character. This is also "=" in the subtract printing programming mode.
+	°C	Programs "°C" (degree Centigrade) character.
+	°F	Programs "°F" (degree Fahrenheit) character.

7. PROGRAMMING





7.3 List of Programming Items

1 Parameters to be Programmed First

Parameters	Key operations	Programming items	Defaults	Programming ranges	Ref. page
Range/ printing range*	SHIFT + 	Range No.	07	01 to 10, 21 to 56, 70 to 80	8.2
		RJ enable/ disable	0	0 (disable), 1 (enable: thermocouple range only)	
		Printing range	0.000 to 5.000	Max. 10 digits (minimum value to maximum value). Excluding decimal point.	
°C/°F calculation	SHIFT +  (3 sec. or more)	—	°C	°C (°C calculation) °F (°F calculation) Thermocouple and resistance thermometer range only	8.3
Chart speed	SHIFT + 	—	20/25 *	0001 to 0600 mm/h or 0001 to 0200 mm/min.	8.4

* AL3000: 20 mm/h, AH3000: 25 mm/h

2 Other Programmable Parameters and Functions

Parameters	Key operations	Programming items	Defaults	Programming ranges	Ref. page
Clock	SHIFT + 	—	Japanese time	2000.01.01.00:00 to 2099.12.31.23:59	11.1
Scale *	SHIFT + 	—	0.000 to 5.000	Max. 11 digits (minimum value to maximum value), excluding decimal point. Printing range reflects to the scale. Therefore no programming is normally necessary for thermocouple and resistance thermometer range.	11.2
Skip *	SHIFT + 	—	Not programmed	Programming is required in [Range/Printing range] programming mode. • Channel to be deleted →Clear the range/printing range. • Channel to be recovered →Program the range/ printing range.	11.3
Subtract printing *	SHIFT + 	—	Not programmed	Programming is required in [Range/Printing range] programming mode. [Subtract printing CH] = [Reference CH] – [subtraction CH*] * Can be replaced with [reference value (with decimal point)].	11.4
Alarm	SHIFT + 	CH/output type	Not programmed	Select from CH (1 to 4), Fail* or C.End (chart end). * Recorders with alarm output (option) only.	11.5
		Level	Not programmed	Up to 4 alarm points can be programmed to each channel (CH 1 to 4).	
		Alarm types	H	Applicable to CH (1 to 4) selected in CH/output type mode. H/L (absolute value high/low limits) E/F (absolute value high/low limits with standby) U/d (rate-of-change increase/decrease limits) b/S (differential high/low limits) J/k (differential high/low limits with standby)	
		Relay No.	0	Applicable to recorders with alarm output (option) Relay No. "0" to "n" can be programmed. ("0": no output), n: number of output points. For recorders without alarm output (option), the number is fixed as "0".	
		Alarm values	Not programmed	Max. 5 digits including (-) sign. Sign is not necessary when U/d, b/S or J/k is selected.	
		Measuring count	Not programmed	1 to 20, Programming required only when U/d is selected.	
		Ref. CH	Not programmed	1 to 4, Programming required only when b/S and J/k are selected.	

* Programming is required to each channel. For 1-pen type, programming is only for CH 1. The items without * mark are programming common to all channels. For "alarm", programming is required to each level of channels.

7. PROGRAMMING

7.3 List of Programming Items

Parameters	Key operations	Programming items	Defaults	Programming ranges	Ref. page
Alarm dead band	SHIFT + \uparrow °C (3 sec. or more)	—	0.1	0.1 to 9.9 (%): % programming of scale span	11.6
Periodic data printing	SHIFT + 5 DATA I	Start time	Not programmed	00:00 to 23:59	11.7
		Interval time	Not programmed	00H05* to 23H59 *Limited by chart speed.	
Engineering unit *	SHIFT + 3 UNIT	—	V	Max. 5 digits (Including numeric values, alphabetic characters, %, /, °C, °F and space) Reflected by "Range No." programmed (mV, V, °C, k)	11.8
Tag *	SHIFT + 6 A-Z	—	Not programmed	Max. 9 digits (Including numeric values, alphabetic characters, %, /, °C, °F and space)	11.9
Message	0 CLEAR + 6 A-Z (3 sec. or more)	No.	Not programmed	1 to 5, Five kinds of messages can be programmed.	11.10
		Message	Not programmed	Max. 15 digits (Including numeric values, alphabetic characters, %, /, °C, °F and space)	
Burnout *	SHIFT + ∇ % (3 sec. or more)	—	non	non, UP bUm, doWn bUm For channels with voltage range, burnout is disabled ("non"), even if burnout is programmed (up or down).	11.11
Passcode/ keylock	SHIFT + \uparrow (3 sec. or more)	Pass code	non	non (not programmed). For programming, use 4 digits from 0 to 9.	11.12
		Key lock	UnLoCkEd	LockEd, UnLoCkEd	
Time axis synchronization	0 CLEAR + 9 LIST (3 sec. or more)	—	oFF	on, oFF	9.6
Input filter*	0 CLEAR + 8 ALARM (3 sec. or more)	Time constant	0	0, 0 to 10 (sec.). "0" means no time constant.	11.13
Copy	SHIFT + (SPACE COPY(=)) (Programming in each programming mode)	—	—	Programmed parameters can be copied to other channels. Available parameters to be copied are [Range/Printing range], [Engineering unit] and [Tag].	11.14

* Programming is required to each channel. For 1-pen type, programming is only for CH 1. The items without * mark are programming common to all channels. For "alarm", programming is required to each level of channels.

3 Programming for Options

Parameters	Programming items	Key operations	Programming contents	Defaults	Programming ranges	Ref. page
Alarm output	Relay No.	SHIFT + 8 ALARM	Relay No.	0	"0" to "n" (n: 6, 12)* In alarm programming mode, program relay Nos. (terminal Nos.) for alarm output. * number of output points	12.1
	AND/OR	0 CLEAR + \uparrow °C (3 sec. or more)	AND/OR	or	AND/OR programming is required for each relay No.	
	Output mode	DISP + \uparrow °C (3 sec. or more)	Relay coil Relay output Alarm display	E U U	E (energize), d (not energize) H (hold), U (not hold) H (hold), U (not hold)	

7. PROGRAMMING

7.3 List of Programming Items

Names	Programming items	Key operations	Programming contents	Defaults	Programming ranges	Ref. page	
Remote contacts	Chart speed (3 speeds)	SHIFT + CHART	Speed No.	1	1 to 3	13.3	
			Speed	20/25*	0001 to 0600 mm/h or 0001 to 0200 mm/min		
	Terminal allocation	CLEAR + DATA I (3 sec. or more)	Terminal No.	1	1 to 4	13.2	
			Operation	non	Selection from 13 items; non, printing on/off & 3 kinds of chart speed, message printing (No. 1 to 2), message printing (No. 1 to 5), operation record (A/B/C/D), digital data printing, list printing (No. 1 to 3) and totalizing reset		
	Operation record	CLEAR + TAG (3 sec. or more)	Printing No.	A	A, B, C, D	13.4	
			Printing position	0	10 to 90%. Printing position when the contact is open. The printing position is at +5 mm when it is shorted.		
Record format	Automatic range shift (Ar)	SHIFT + DISP	Format	Sd	Select Ar from Sd (standard), Ar, SP, and PL.	14.1	
			Channel	Not programmed	1 to 4		
			Zero for range 1	Not programmed	a (Minimum value \leq a < b)		
			Span for range 1	Not programmed	b (a < b < c)		
			Span for range 2	Not programmed	c (b < c < d)		
			Span for range 3	Not programmed	d (c < d < e)		
			Span for range 4	Not programmed	e (d < e < f)		
			Span for range 5	Not programmed	f (e < f \leq maximum value)		
	Compressed/Expanded (SP)	SHIFT + DISP	Format	Sd	Select SP from Sd (standard), Ar, SP, and PL.	14.2	
			Channel	Not programmed	1 to 4		
			Printing position for broken point 1	Not programmed	0 to a (%)		
			Printing position for broken point 2	Not programmed	a to 100 (%)		
			Scale at zero	Not programmed	b (Minimum value \leq b < c)		
			Scale for broken point 1	Not programmed	c (b < c < d)		
			Scale for broken point 2	Not programmed	d (c < d < e)		
			Scale for span	Not programmed	e (d < e \leq maximum value)		
	Zone scale (PL)	SHIFT + DISP	Format	Sd	Select PL from Sd (standard), Ar, SP, and PL.	14.3	
			CH for area 1	Not programmed	1 to 4		
			CH for area 2	Not programmed	1 to 4 (Except channels for area 1)		Area 1 and 2 only for AL 3000
			CH for area 3	Not programmed	1 to 4 (Except channels for area 1 and 2)		
			CH for area 4	Not programmed	1 to 4 (Except channels for area 1 to 3)		
	Communications interface	Protocol	SHIFT + SPACE COPY(=) (3 sec. or more)	For details, refer to the separate instruction manual for "Communications Interface".			15.1
		Specifications	SHIFT + (-) (3 sec. or more)				15.2

* AL3000: 20 mm/h, AH3000: 25 mm/h

This section explains the basic programming parameters.

1 Basic of Programming Flow Chart

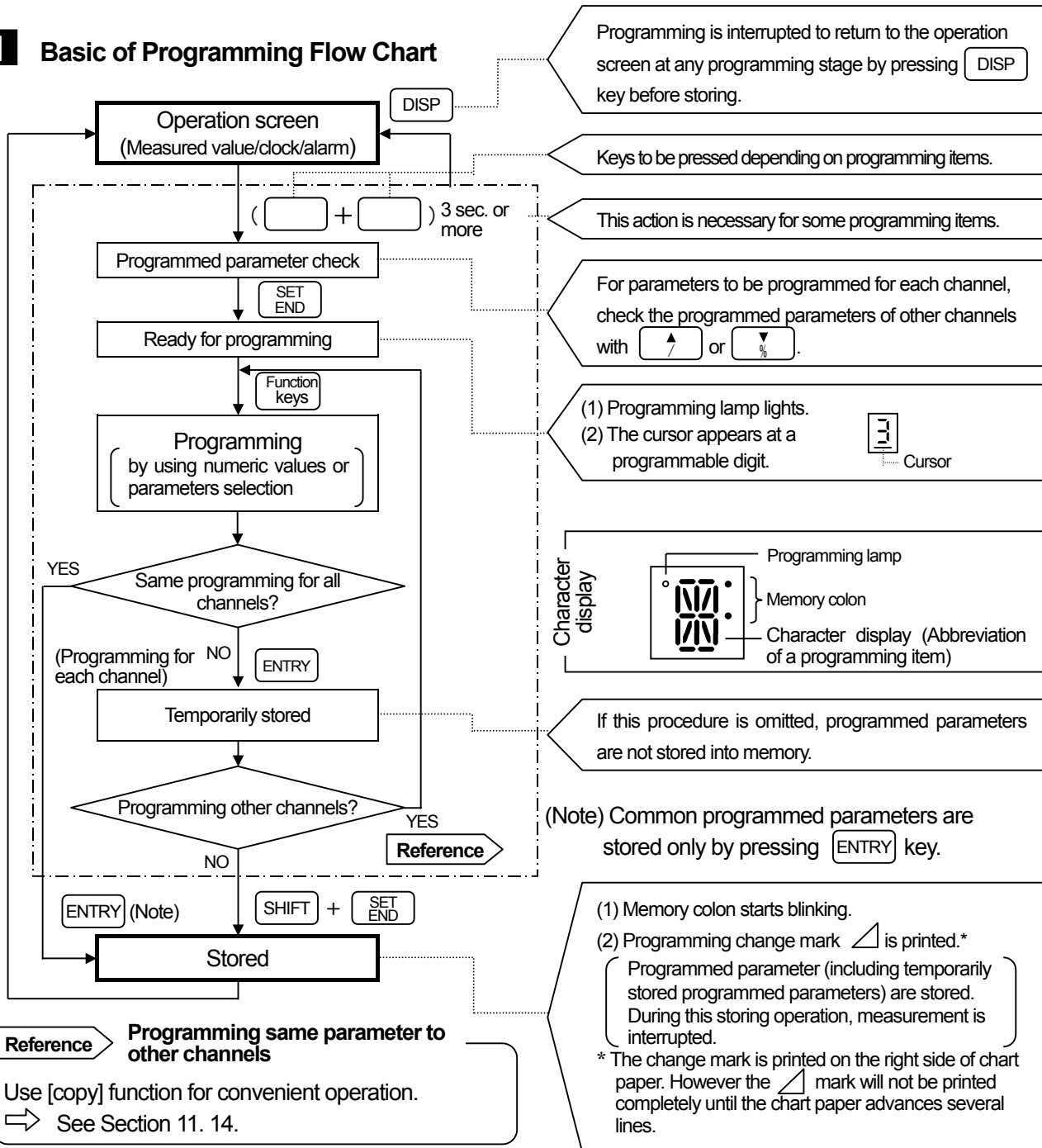

2 Key Operation

1) Numeric keys and cursor

- Cursor shifts rightward when pressing numeric keys (**0 CLEAR** to **9 LIST** and **±(-)**).
- Press **↔F** or **↔C** for moving the cursor.

2) How to add or delete a decimal point

- To add the decimal point move the cursor to **□.□** and press **CLOCK**. To delete the decimal point, press **SPACE COPY(=)**. (Numeric value is also deleted.)

3) Clearing a displayed programmed parameter

- The programmed parameter is cleared by pressing **SHIFT** and **0 CLEAR** simultaneously.

7. PROGRAMMING

7.5 Programming Errors and Remedial Measures

An error for the programmed parameter is judged when pressing **ENTRY** during [Storing] or [Temporarily storing] procedures.

1 Error Judgement Flow Chart

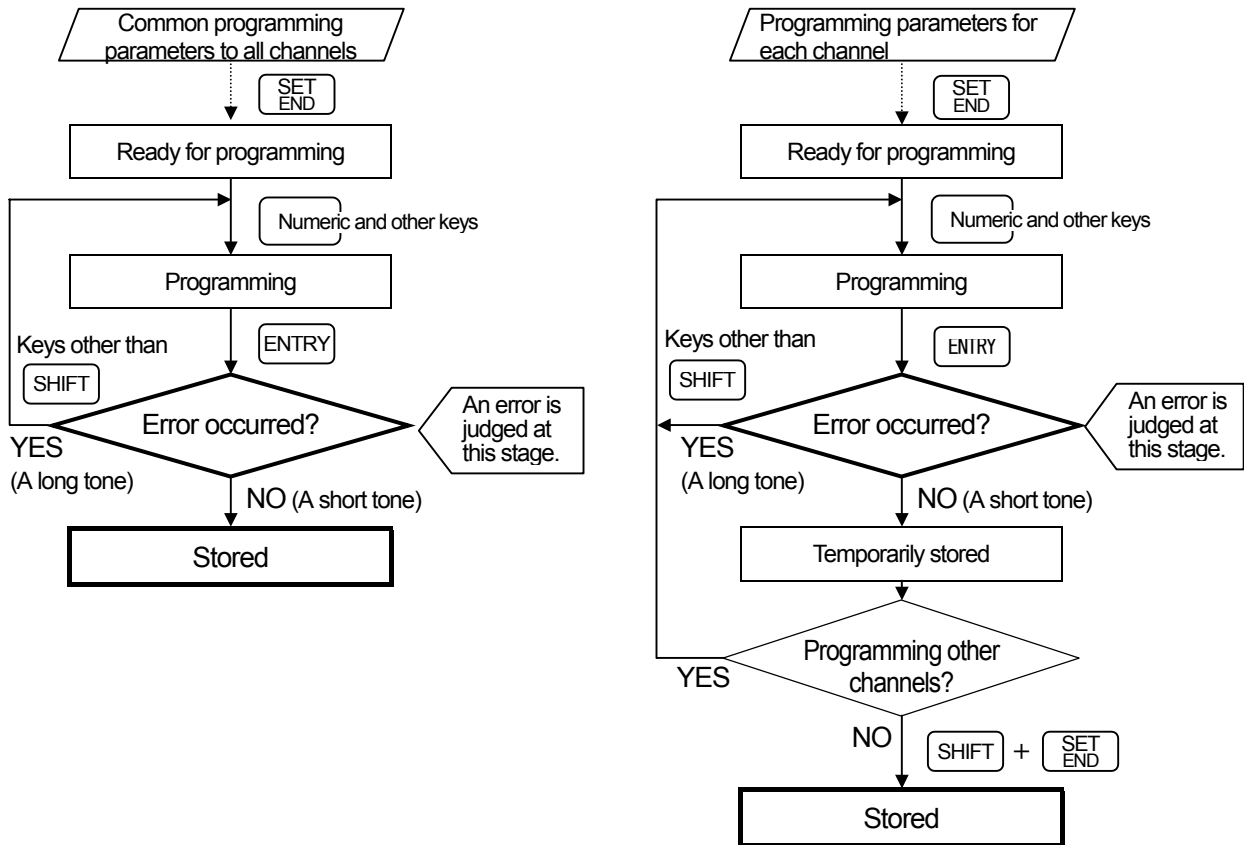

2 Type of Errors and Error Display

If a programmed parameter is in error, a long tone (approx. 0.5 sec.) sounds and no storing (or temporarily storing) is executed.

Error type	Format error	Programming error
Display	<div style="border: 1px solid black; padding: 2px; display: inline-block;">F o r E r r o r</div> →Blinks	<div style="border: 1px solid black; padding: 2px; display: inline-block;">S e t E r r o r</div> →Blinks
Details	Programmed parameter format is in error. [1234] was programmed to [12-34] or the like, for example.	A numeric value out of programming range was programmed.

3 Remedial measures when an error occurs

If any key other than **SHIFT** is pressed, it returns to the programmed parameter display. The cursor appears and reprogramming can be executed. Reprogram by entering correct value.

8. BASIC PROGRAMMING

8.1 Programming Parameters Before Operation

Certain parameters are to be programmed for starting operation after turning on the power supply.

1 Turning On the Power supply

By turning on the power supply for the first time, the display and printing operation start with default parameters. Perform the basic programming to match your purpose before operation.

Default parameters

Range/ Printing range	07 (± 5 V)/0.000 to 5.000 (V)
$^{\circ}$ C/ $^{\circ}$ F selection	$^{\circ}$ C calculation
Chart speed	AL3000: 20 mm/h AH3000: 25 mm/h

2 Basic Programming Parameters

Be sure to program the following three parameters before operation.

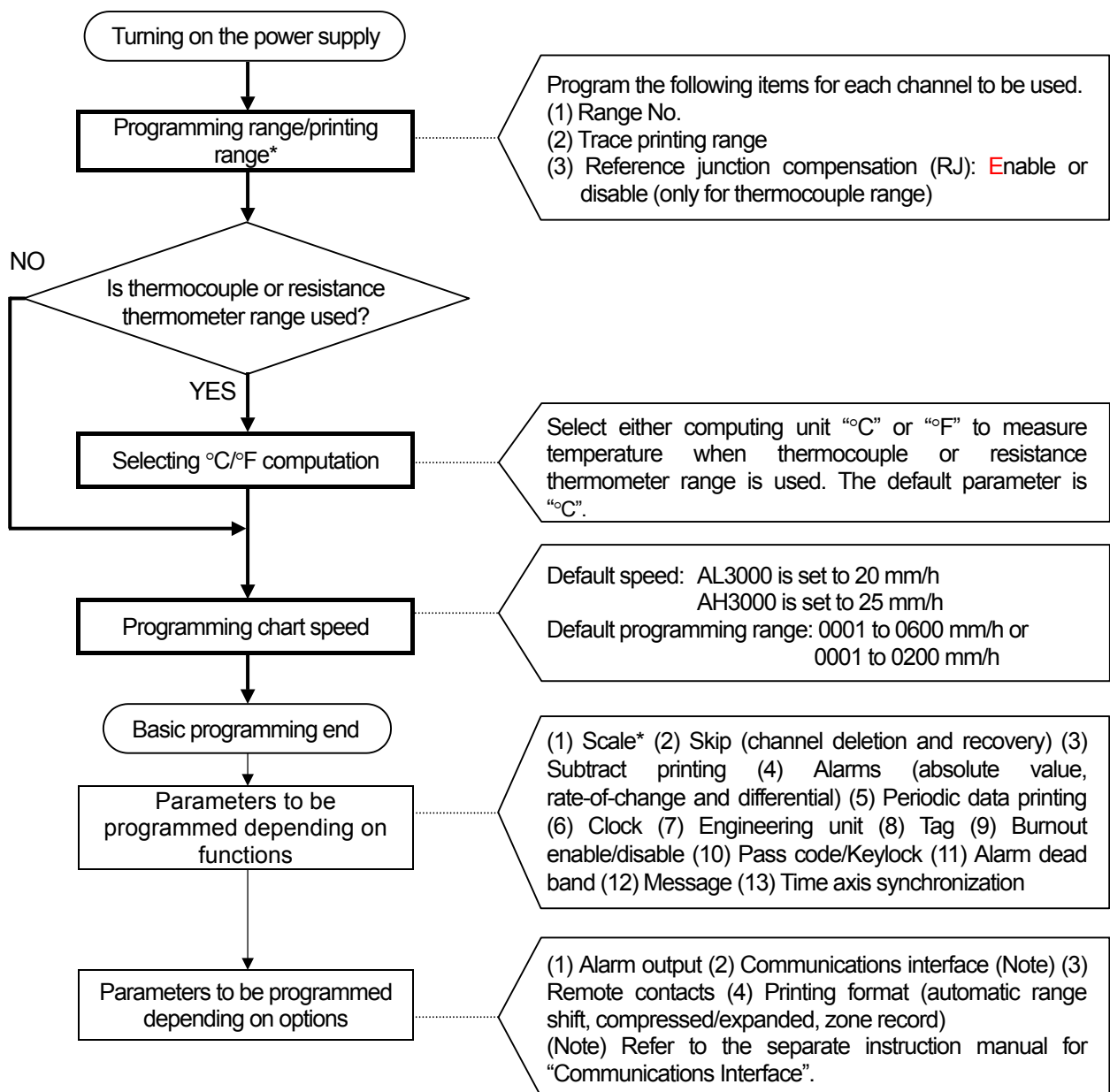

* When the printing range is set, that value reflects to the “Scale” setting. For the scaling with voltage input, read the Section 11.2.

8. BASIC PROGRAMMING 8.2 Range/Printing Range

Program the following parameters before operation. Press **SHIFT** and **RANGE** simultaneously at the operation screen to display the "Range/Printing range" programming screen. Programming of the parameter is required in every channel.

1 Programming Mode and Parameters

1) Programming mode

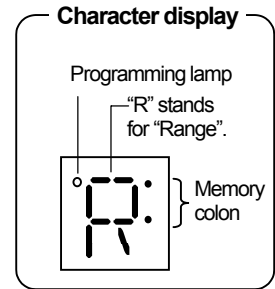
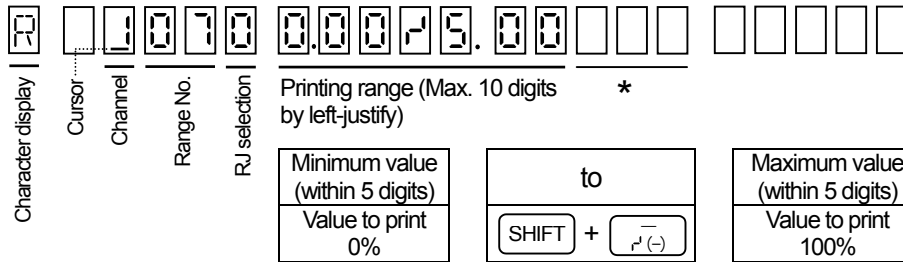

* Unused digits should be filled with spaces.

2) Parameters

Program the following three parameters for every channel.

Parameters	(1) Range No.	(2) RJ selection	(3) Printing range
Purpose	Selection of input types and measuring ranges	Selection of reference junction compensation (RJ) enabled or disabled	Specifying of the input range to be printed on the chart paper.
Programming values	Range No. (2-digit numeric value) For a range No. table, see item 4 .	0: Disable (external compensation) 1: Enable (internal compensation) Program to "0" for all inputs other than thermocouple input.	Minimum value to maximum value (within 5 digits) This range can be programmed irrespective of the measuring range being specified in the range No. selected. (Note)

(Note) Input exceeding the measuring range or printing range is printed as an over-range.

2 Cautions on Programming and Reference

Read the following cautions and reference items. The programming flow charts are described on the next page.

1) Minimum printing range

Read the "minimum printing range" on Section 22.1 (Input Specifications). A programming error occurs if the minimum value and the maximum value are set to the same figure.

2) Position of decimal point

The printing range reflects to the scale value. The decimal point position on actual display/printing is fixed by the range No. selected. For changing it, refer to the scale programming.

Range No. (Measuring range)	Printing range	Scale	Actual position of decimal point
07 (-5.000 to 5.000 V)	0 to 5	0 to 5	0.000 to 5.000
21 (-200.0 to 300.0°C)	0 to 200	0 to 200	0.0 to 200.0
23 (-200 to 1370°C)	0.0 to 800.0	0.0 to 800.0	0 to 800

3) When "Range/Printing range" is changed, the last scale value becomes ineffective and is replaced with the new printing range.

4) Channel for subtract printing

Different range programming procedure is required. Read Section 11.4 (Programming Subtract Printing).

5) Programming a same range to other channels

The [copy] function is useful. Read Section 11.14.

6) Scaling

Printing range reflects to the scale value. For scale programming to the channel with voltage input, read Section 11.2.

8. BASIC PROGRAMMING 8.2 Range/Printing Range

3 Programming Flow Chart

<Example> Range No. for channel 3: 22, RJ: Enable, Printing range: -50 to 450°C

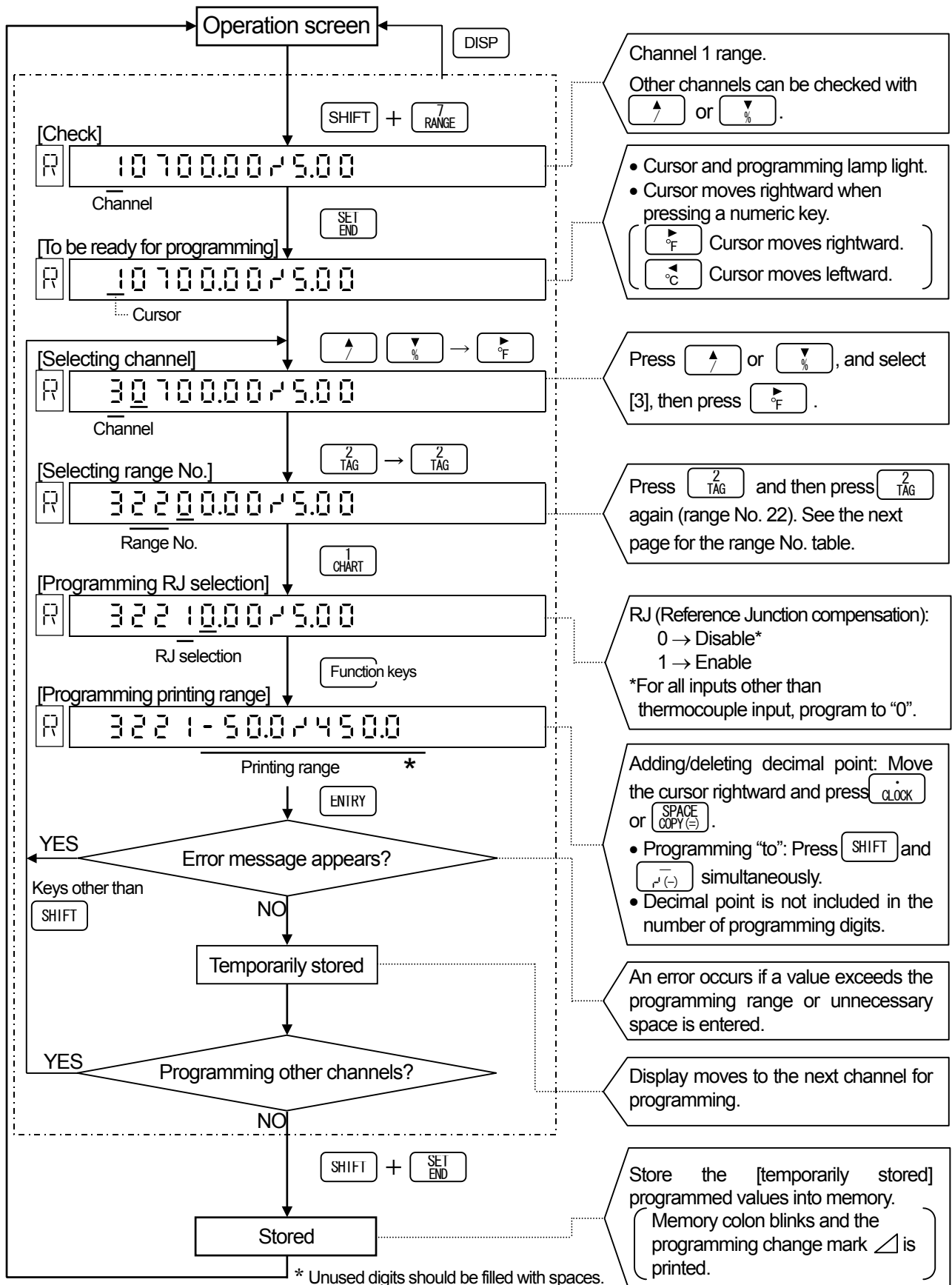

8. BASIC PROGRAMMING 8.2 Range/Printing Range

4 Range No. Tables

1) Voltage input

No.	Input type	Measuring range	Remarks
01	DC (mV)	-13.80 to 13.80 mV	For current input, see Item 16.2.
02		-27.60 to 27.60 mV	
03		-69.00 to 69.00 mV	
04		-200.0 to 200.0 mV	
05		-500.0 to 500.0 mV	
06	DC (V)	-2.000 to 2.000 V	
07		-5.000 to 5.000 V	
08		-10.00 to 10.00 V	
09		-20.00 to 20.00 V	
10		-50.00 to 50.00 V	

No.	Input type	Measuring range	
		°C	°F
40	W-WRe26	0 to 2315	32 to 4200
41	WRe5-WRe26	0 to 2315	32 to 4200
43	PtRh40-PtRh20	0 to 1888	32 to 3400
44	NiMo-Ni	-50.0 to 290.0	32.0 to 550.0
45		-50.0 to 600.0	32 to 1110
46		50 to 1310	32 to 2350
47	CR-AuFe	0.0 to 280.0K	0.0 to 300.0K
48	Platinel II	0.0 to 350.0	-140.0 to 660.0
49		0.0 to 650.0	-140 to 1200
50		0 to 1390	-140 to 2530
51	U	-200.0 to 250.0	-320.0 to 480.0
52		-200.0 to 500.0	-320.0 to 930.0
53		-200.0 to 600.0	-320 to 1110
54	L	-200.0 to 250.0	-320.0 to 480.0
55		-200.0 to 500.0	-320.0 to 930.0
56		-200 to 900	-320 to 1650

2) Thermocouple input (*1)

No.	Input type	Measuring range	
		°C	°F
21	K	-200.0 to 300.0	-320.0 to 570.0
22		-200.0 to 600.0	-320 to 1110
23		-200 to 1370	-320 to 2490
24	E	-200.0 to 200.0	-320.0 to 390.0
25		-200.0 to 350.0	-320.0 to 660.0
26		-200 to 900	-320 to 1650
27	J	-200.0 to 250.0	-320.0 to 480.0
28		-200.0 to 500.0	-320.0 to 930.0
29		-200 to 1200	-320 to 2190
30	T	-200.0 to 250.0	-320.0 to 480.0
31		-200.0 to 400.0	-320.0 to 750.0
32	R	0 to 1200	32 to 2190
33		0 to 1760	32 to 3200
34	S	0 to 1300	32 to 2370
35		0 to 1760	32 to 3200
36	B	0 to 1820	32 to 3300
37	N	-200.0 to 400.0	-320.0 to 750.0
38		-200.0 to 750.0	-320 to 1380
39		-200 to 1300	-320 to 2370

3) Resistance thermometer input (*2)

No.	Input type	Measuring range	
		°C	°F
70	Pt100 (JIS'97)	-140.0 to 150.0	-220.0 to 300.0
71		-200.0 to 300.0	-320.0 to 550.0
72		-200.0 to 850.0	-320 to 1560
73	Pt100 (QPt100 JIS'89)	-140.0 to 150.0	-220.0 to 300.0
74		-200.0 to 300.0	-320.0 to 550.0
75		-200.0 to 649.0	-320 to 1200
76	JPt100	-140.0 to 150.0	-220.0 to 300.0
77		-200.0 to 300.0	-320.0 to 550.0
78		-200.0 to 649.0	-320 to 1200
79	Pt50	-200.0 to 649.0	-320 to 1200
80	Pt-Co	4.0 to 374.0K	4.0 to 374.0K

*1: (1) No.21 to 39: IEC584, JIS C 1602-1995
 (2) No.40 to 50: ASTM
 (3) No.51 to 56: DIN43710

*2: (1) No.70 to 72: IEC751(1995), JIS C 1604-1997
 (2) No.73 to 75: IEC751(1983), JIS C 1604-1989
 JIS C 1606-1989
 (3) No.76 to 78: JIS C 1604-1981
 JIS C 1606-1989
 (4) No.79: JIS C 1604-1981

Remarks

Decimal point position and engineering units

Decimal point position: Even if the decimal point position is programmed in the printing range, the actual display/printing position is shown as described in the table above depending on the range No. For changing the decimal point position, see Section 11.2 "Scale programming".

Engineering units: Engineering unit is shown as described in the table above depending on range No. (Temperature unit is fixed to "°C" except No. 47 and 80). For changing the engineering unit, see Section 11.8 "Unit programming".

8. BASIC PROGRAMMING 8.3 °C/°F Computation Selection

This programming is to select a “°C” or “°F” computation for a temperature range (thermocouple or resistance thermometer). The default setting is “°C”. Press **[SHIFT]** and **[°F]** simultaneously 3 seconds or more in the operation screen to display the “°C/°F computation” selection screen. Select “°F” if necessary.

1 Programming Mode

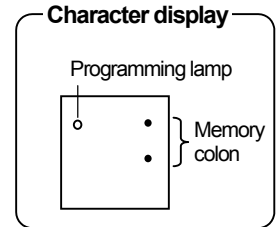
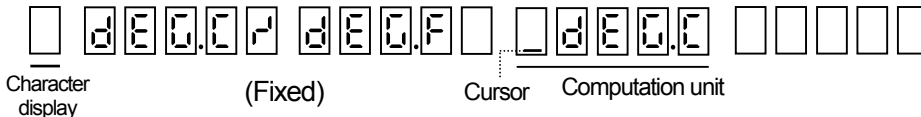

2 Programming Flow Chart

<Example> From “°C” computation to “°F” computation

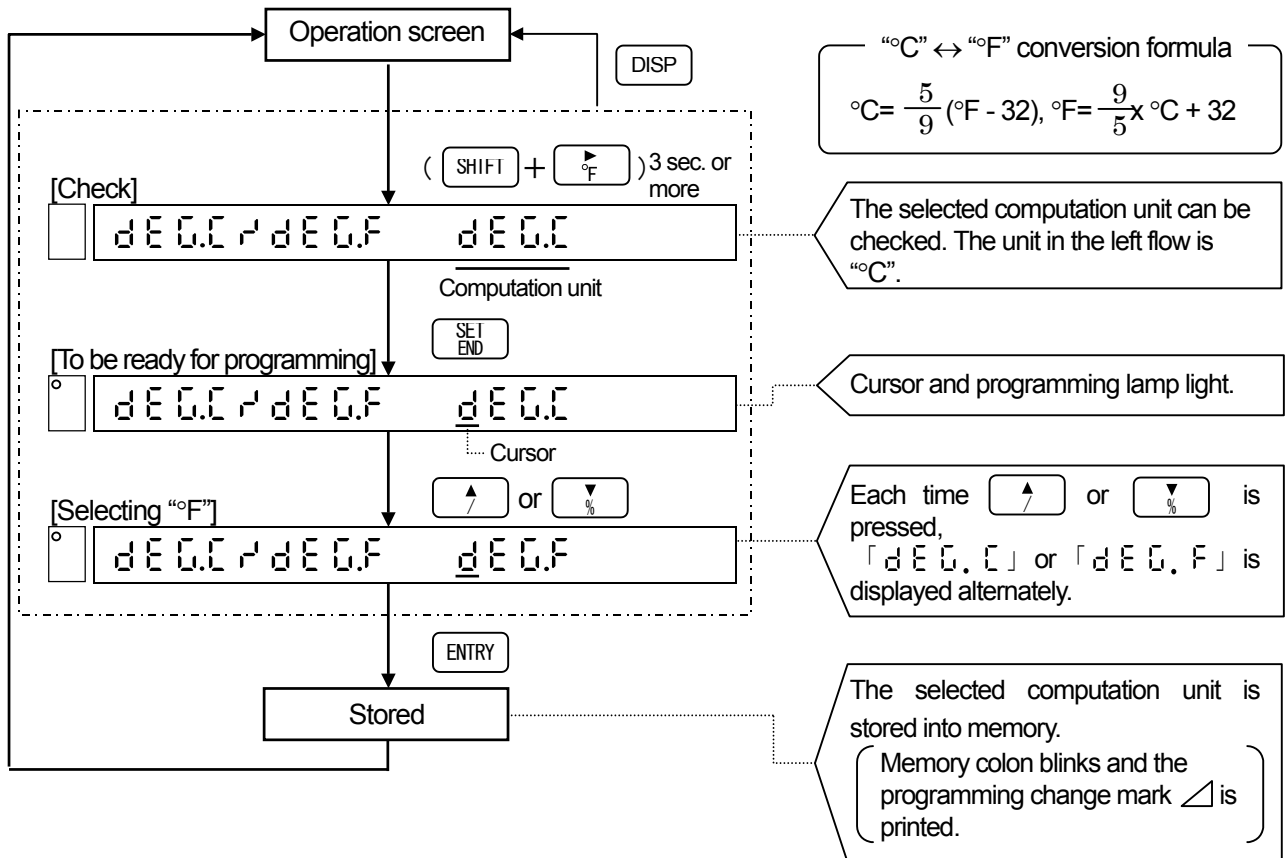

Remarks Relation with other programming items

1) In case of temperature unit “K”

The temperature unit for the range No.47 (AuFe-CR) and 80 (Pt-Co) is “K”. It does not affect this programming.

2) Influence onto other programmed parameters

The programmed parameters for “Range/Printing range”, “Scale” and “Alarm setpoint” are not changed automatically. If the programmed parameters cannot be used for the selected computation unit, reprogram them again. Even if “°C” or “°F” is programmed at the “Engineering unit programming”, it does not change the computation.

8. BASIC PROGRAMMING 8.4 Chart Speed Programming

Program the chart speed before operation.

- Press **[SHIFT]** and **[CHART]** simultaneously in the operation screen to display the [Chart speed] programming screen.
- For the remote contacts (option), read Section 13.3.
- 0000mm/h can be set for AH3000. When 0000mm/h is set, chart is fed at the speed of 12.5mm/h.

Programming range
 0001 to 0600 (mm/h)
 or
 0001 to 0200 (mm/h)

1 Programming Mode

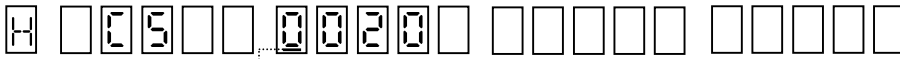

Speed unit (Fixed) (H/M) Cursor Chart speed (4 digits programming)

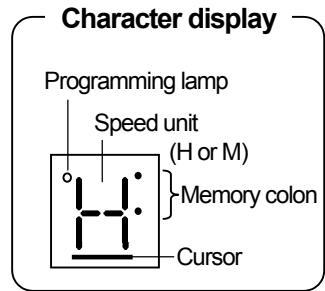

2 Programming Flow Chart

<Example> From 20 mm/h to 50 mm/h

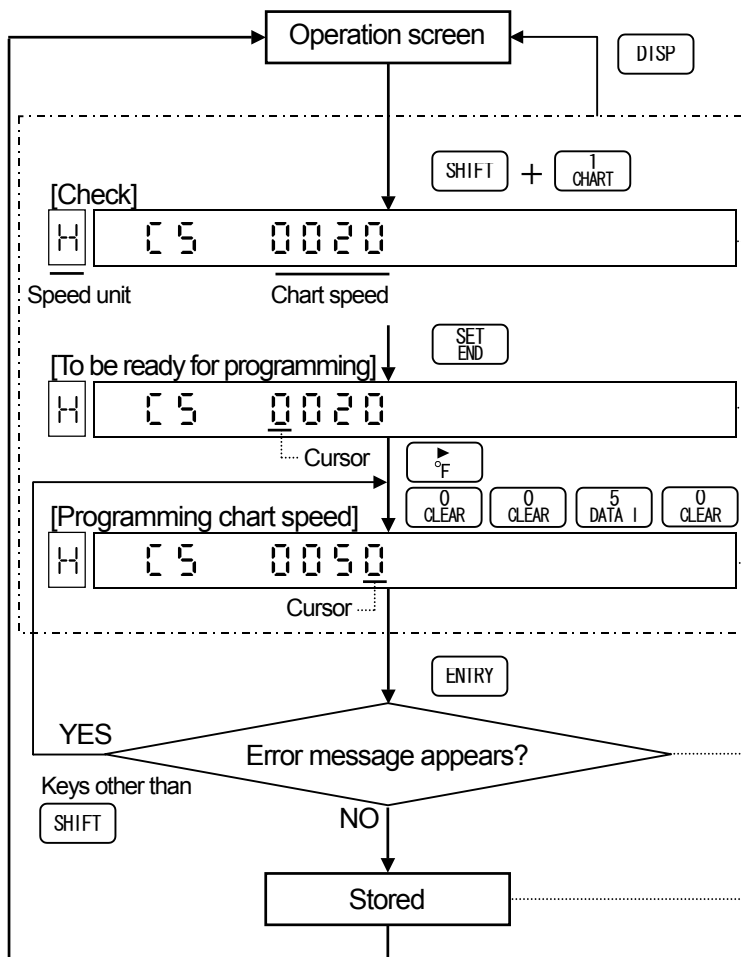

Changing the speed unit (h/m)
 Move the cursor to the character display (a digit on the left) then press **[↑]** or **[↓]** to switch “M” and “H” alternatively.

Programmed chart speed

- Cursor and programming lamp light.
 - Cursor moves rightward when pressing a numeric key.
- [→]** Cursor moves rightward.
[←] Cursor moves leftward.

Program the chart speed within 0001 to 0600 mm/h or 0001 to 0200 mm/min.

An error occurs if a value exceeds the programming range or any space or decimal point is entered.

The new programmed value is stored into memory.
 Memory colon blinks and the programming change mark **△** is printed.

Remarks 1 **If 150 mm/h or more is programmed for the chart speed**
 No printing, except time line, data printing and programming change mark, is executed.

Remarks 2 **Influence to periodic data printing**
 When changing the chart speed, the programmed parameters for [periodic data printing] (Section 11.7) is cleared. (Default: Not programmed)

9. PRINTINGS

9.1 Printing Types and the Details

Printing comprises trace printing and digital printing. The fixed-time printing and trace printing are executed even if any operation is not programmed.

1 Printing Types and the Details

Printing type	Printing details	Remarks						
Trace printing (Cartridge pen)	Trend printing is executed for each pen (channel)	_____						
	<table border="1"> <tr> <td>1st pen</td> <td>2nd pen</td> <td>3rd pen</td> <td>4th pen</td> </tr> <tr> <td>Red</td> <td>Green</td> <td>Blue</td> <td>Brown</td> </tr> </table>		1st pen	2nd pen	3rd pen	4th pen	Red	Green
1st pen	2nd pen	3rd pen	4th pen					
Red	Green	Blue	Brown					
Digital Data Printing (Plotter pen)	Fixed-time printing	The following details are printed on the fixed time. (1) Year/Month/Day (2) Time (3) Time line (4) Chart speed (5) Scale, Engineering unit, Tag	10-1					
	Periodic data printing	Measured values are printed on the trace printing with programmed intervals. The printing starts from the programmed start time line. The printing mode is different depending on chart speed.	11-7					
	Digital data printing	Measured values are printed on the trace printing. The printing mode is different depending on chart speed.	9-2					
	List 1 printing	Major parameters (Range/Printing range, Scale, Subtract printing, Periodic data printing) are printed as a table.	9-3					
	List 2 printing	The parameters (such as time axis synchronizing, message, items relating to options) other than those involved in List 1 are printed as a table.	9-3					
	List 3 printing	All parameters (List 1 + List 2) are printed as a table.	9-3					
	Message printing	Message is printed on the right side of the chart paper by selecting the programmed message No.	9-4					
	Alarm printing	Alarm details (time, alarm points, alarm type) are printed on the right side of the chart paper when an alarm activates or an alarm is reset.	10-4					
	Time axis sync. mark printing	(1) When the time axis synchronization (POC) is switched on or off, its time, mark (*), and ON or OFF are printed on the right side of the chart paper. (2) When it is ON, a mark (*) is printed to the right of the time print of fixed-time printing.	9-6 10-1					
	Power-on printing	Year/Month/Day and time are printed on the left side of the chart paper when the power is turned on.	6-1					
	Operation printing line and Operation printing No.	For the remote contacts (option), it is required to program the "Operation printing position" and select one of Act 1 to 4 in the "Remote contacts" programming. (1) Printing line: When a contact signal (on) is applied to the allocated terminal, the line is printed by 5 mm to the right of the programmed printing line position. (2) Operation printing No.: Operation printing No. (A to D) is printed at constant intervals to the left of the programmed printing line position.	13-4					
Printer check printing	When hardware check is executed by selecting the printer (plotter pen) characters are printed for checking purpose.	19-2						

9. PRINTINGS | **9.1 Printing Types and the Details**

2 Printing Examples

1) AL3000 (Printing width: 100 mm)

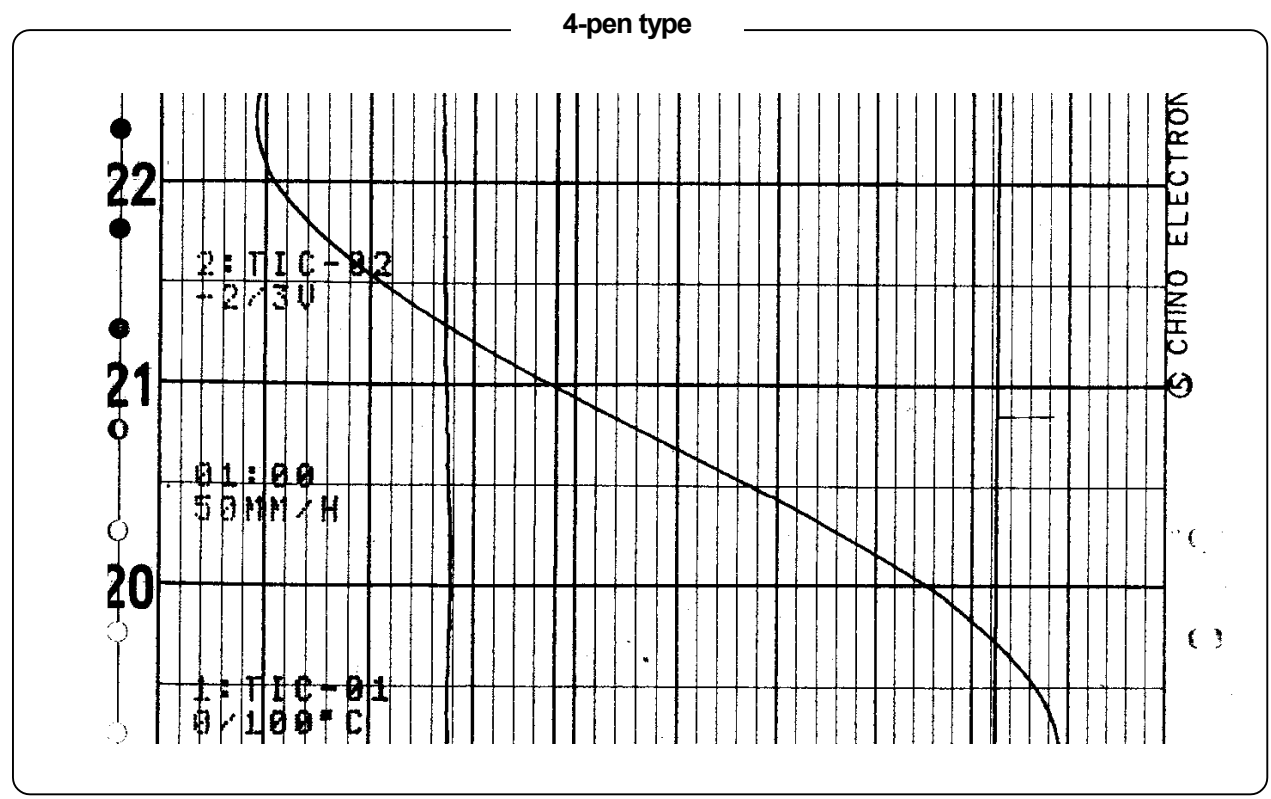

2) AH3000 (printing width: 180 mm)

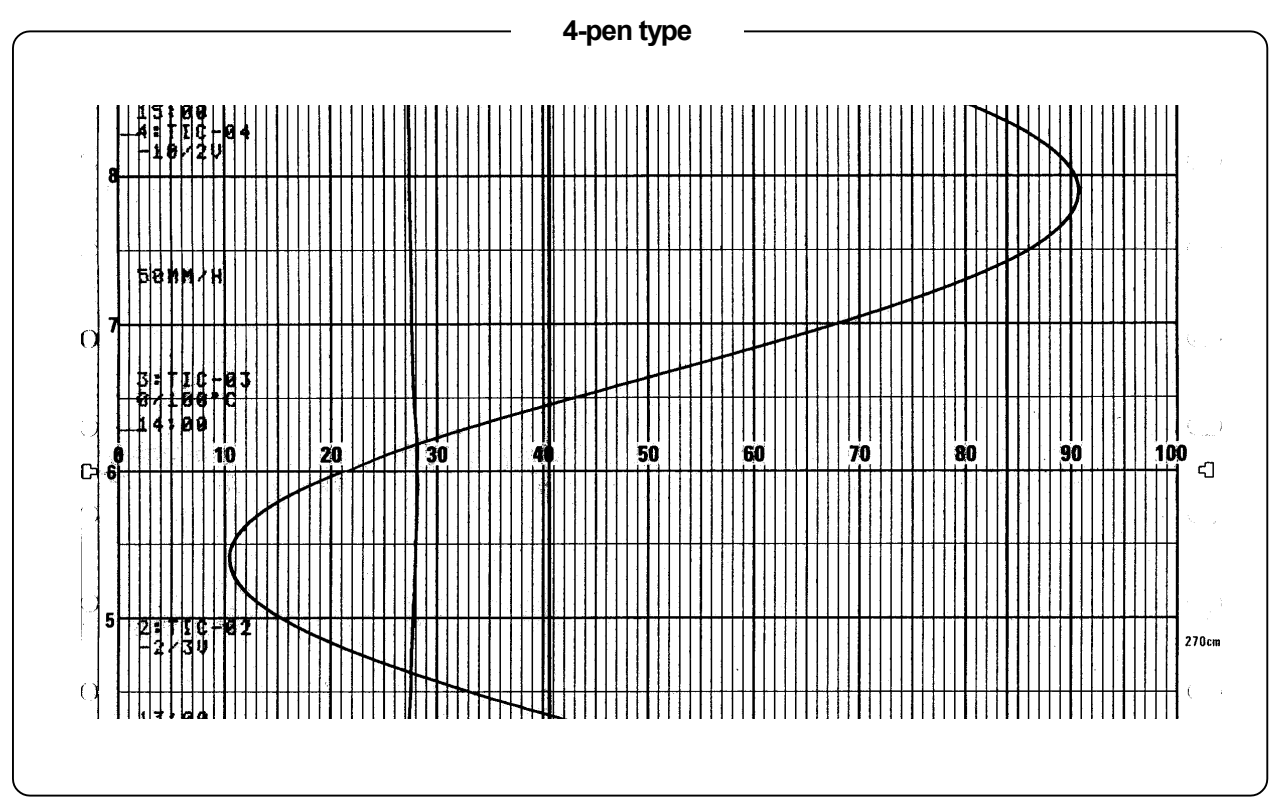

9. PRINTINGS

9.2 Digital Data Printing

The measured value at the moment **DATA PRINT** pressed is digitally printed with the plotter pen.

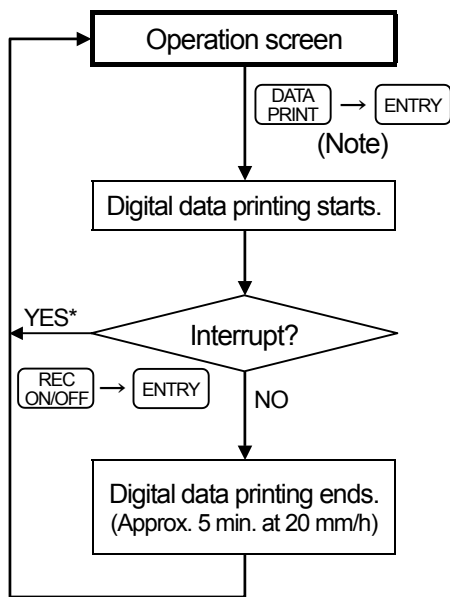

* With this procedure, the printing operation turns off.
Press **REC ON/OFF** and **ENTRY** again to turn it on.

- Press **DATA PRINT** and then press **ENTRY**. Digital printing of measured value at the moment **DATA PRINT** pressed starts.
(Note) When **DATA PRINT** is pressed, **PUSH ENTRY** appears for about 5 sec. Press **ENTRY** while this message appears.
 - Printing mode is different depending on the chart speed.

Chart speed	Printing mode
0 to 499mm/h	Analog printing is continued without interruption.
500 mm/h or more	Analog printing is interrupted and data printing is started.

- For interrupting the printing, press **REC ON/OFF** and then press **ENTRY**. Your recorder returns to the normal operation but the printing operation is turned off. For turning on the printing operation, press **REC ON/OFF** and then press **ENTRY** again.
- When the digital data printing completes, your recorder returns to the normal operation.

Remarks

Digital data printing cannot be executed in the following conditions.

- RECORD ON** status lamp is not lit.
- KEY LOCK** status lamp lights.

Example of Digital data printing (4-pen type)

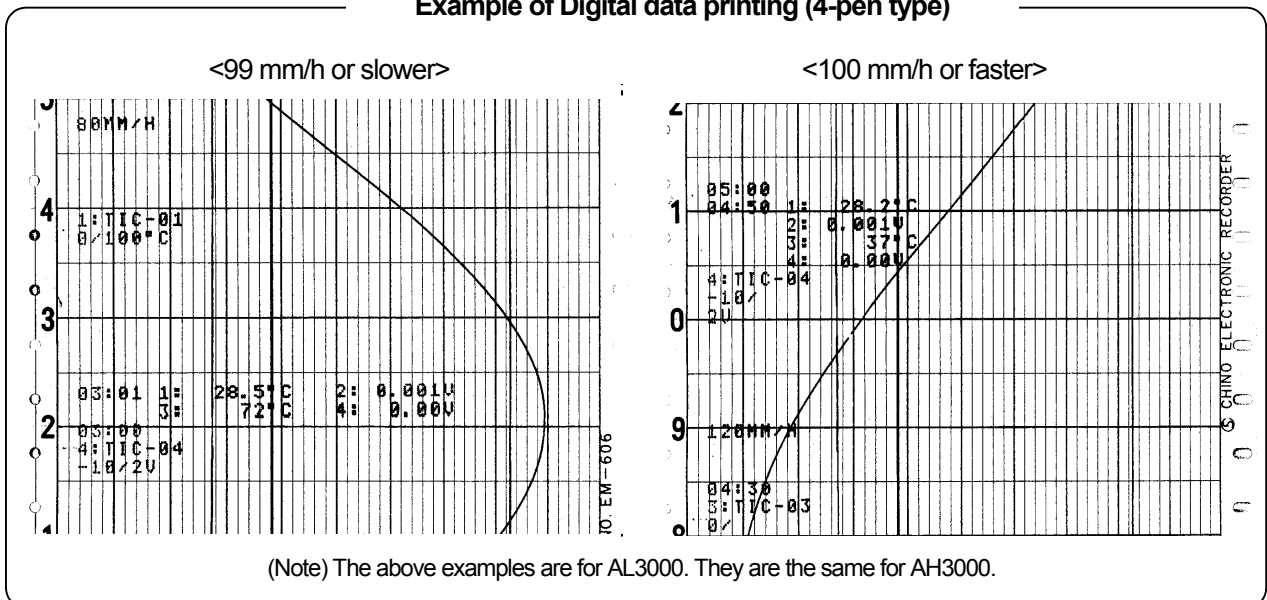

9. PRINTINGS

9.3 List Printing

The details of programming such as "Range/Printing range" and "Scale" can be printed as a list with the plotter pen. As this includes large amount of data and takes time, it enables to divide the data into two and select printing of "List 1" or "List 2".

List 1: Major parameters "Range/Printing range", "Chart speed", "Printing format", etc.

List 2: Parameters other than the above "Message", "Time axis synchronization." and "option-related-items"

List 3: All parameters "List 1" + "List 2"

1 List 1 Printing

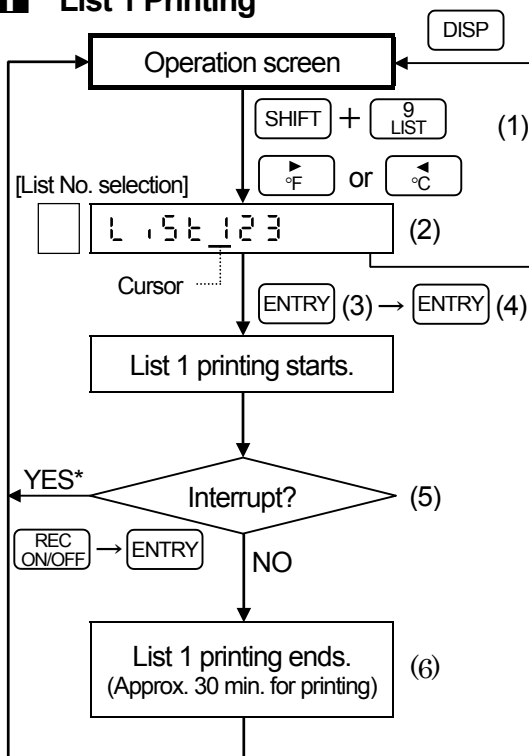

* With this procedure, the printing operation turns off. Press **REC ON/OFF** and then press **ENTRY** again to turn it on.

Remarks

List 1 printing cannot be executed in the following conditions.

- (1) **RECORD ON** status lamp is not lit.
- (2) **KEY LOCK** status lamp lights.

Chart speed does not affect to this operation.
Chart paper forwards at a fixed speed.

Reference

Operation during printing

- (1) Trace printing with a cartridge pen is interrupted. Other functions are continued without being interrupted.
- (2) Programming any parameters (Range/Printing range, Scale, Alarm, etc.) cannot be executed during printing. Program them after the printing ends.

- (1) Press **SHIFT** and **9 LIST** simultaneously, and then press **ENTRY**.
- (2) The selection screen from [List 1] to [List 3] appears. Move the cursor to "1".
- (3) When **ENTRY** is pressed, **PUSH ENTRY** appears for about 5 sec. For execution, go to procedure (4). For no execution, press **DISP**.
- (4) Press **ENTRY** to start "List 1" printing. The cartridge pen moves to the end of the left side and the chart paper forwards slightly.
- (5) For interrupting the printing, press **REC ON/OFF** and **ENTRY** simultaneously. Your recorder returns to the normal operation but the printing operation is turned off. For turning on the printing operation, press **REC ON/OFF** and then press **ENTRY** again.
- (6) When the list printing completes, your recorder returns to the normal operation.

List 1 printing details

- | | |
|--------------------------|----------------------------|
| (1) Year/month/day, Time | (2) Chart speed (Note) |
| (3) Range/Printing range | (4) Scale |
| (5) Subtract printing | (6) Periodic data printing |
| (7) Printing format | (8) Alarm |
- (Note) When the remote contacts (option), which can program 3 speeds (No.1 to No.3), is added, the presently selected speed is printed.

Example of the List 1 printing

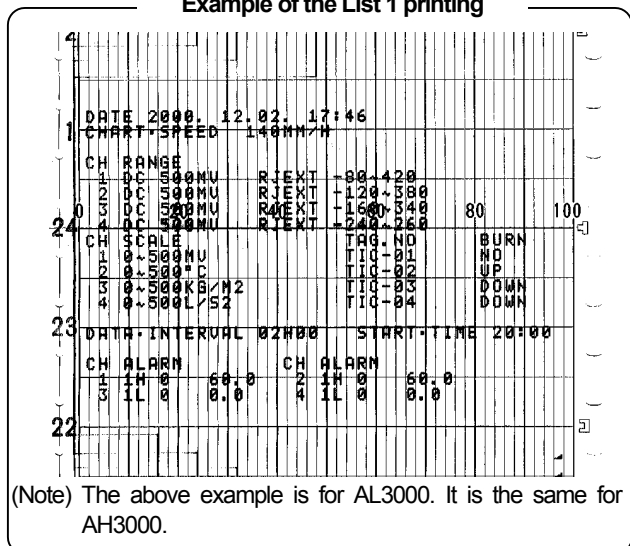

2 List 2 Printing

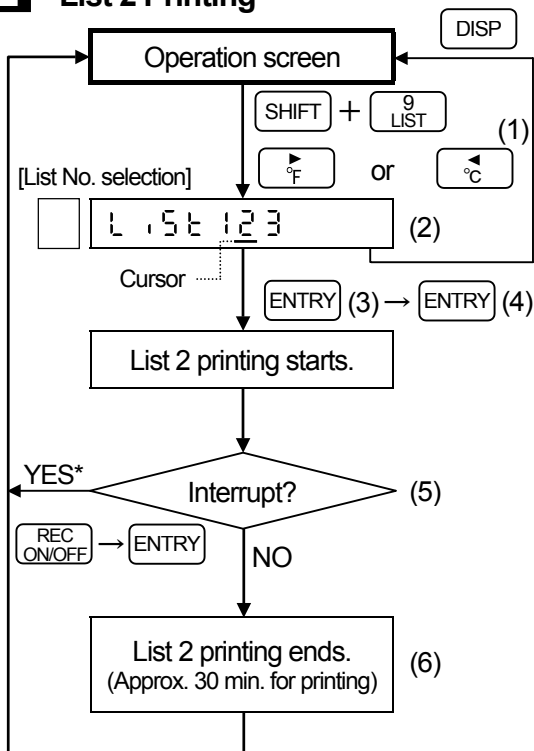

* With this procedure, the printing operation turns off. Press **REC ON/OFF** and then press **ENTRY** again to turn it on.

Remarks

List 2 printing cannot be executed in the following conditions.

- (1) **RECORD ON** status lamp is not lit.
 - (2) **KEY LOCK** status lamp lights.
- Chart speed does not affect this operation.
Chart paper forwards at a fixed speed.

Reference

Operation during printing

Trace printing with a cartridge pen is not interrupted. Other functions are continued without being interrupted.

- (1) Press **SHIFT** and **9 LIST** simultaneously, and then press **ENTRY**.
- (2) The selection screen from [List 1] to [List 3] appears. Move the cursor to "2".
- (3) When **ENTRY** is pressed, **PUSH ENTRY** appears for about 5 sec. For execution, go to procedure (4). For no execution, press **DISP**.
- (4) Press **ENTRY** to start "List 2" printing. The cartridge pen moves to the end of the left side and the chart paper forwards slightly.
- (5) For interrupting the printing, press **REC ON/OFF** and **ENTRY** simultaneously. Your recorder returns to the normal operation but the printing operation is turned off. For turning on the printing operation, press **REC ON/OFF** and then press **ENTRY** again.
- (6) When the list printing completes, your recorder returns to the normal operation.

List 2 printing details

- | | |
|--------------------------|------------------------|
| (1) Year/month/day, Time | (2) Chart speed (Note) |
| (3) Alarm outputs | (4) Time axis sync |
| (5) Message | (6) Operation record |
| (7) Remote contacts | (8) Mathematics |
- (Note) For the remote contacts (option), which can program 3 speeds (No.1 to No.3), is added, all programmed 3 speeds are printed.

Example of the List 2 printing

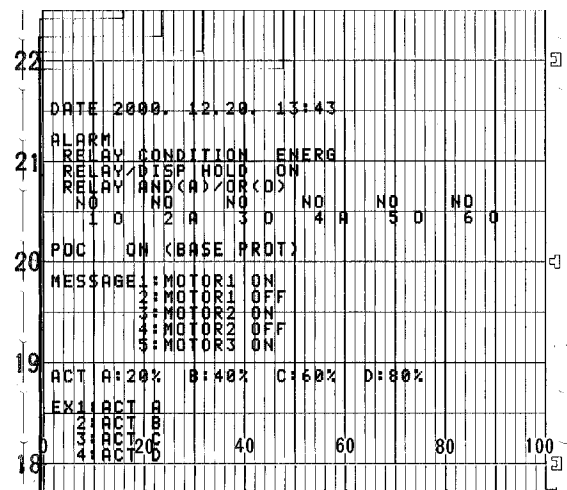

(Note) The above example is for AL3000. It is the same for AH3000.

3 List 3 Printing

Move the cursor to "3" at the [List No. selection] and execute the same procedure as item **2**. All of the programmed parameters are printed.

9. PRINTING

9.4 Message Printing

For printing of a pre-programmed message, select the message No. and press **ENTRY**.

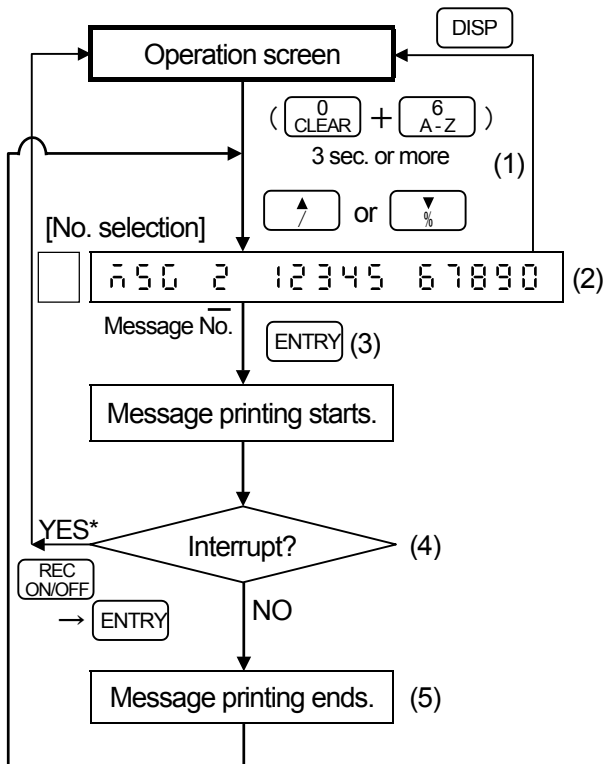

- (1) Press **0 CLEAR** and **6 A-Z** simultaneously for 3 seconds or more.
- (2) Select the message No. (1 to 5) to be printed with **7** or **8**.
- (Note) Refer to Section 11.10 for programming of message.
- (3) Press **ENTRY** to start "Message" printing with a plotter pen on the right side of the chart paper.
- (Note) The "message" will not be printed completely until the chart paper forwards several lines.
- (4) For interrupting the printing, press **REC ON/OFF** and then press **ENTRY**. The printing operation is turned off and your recorder returns to the normal operation. For turning on the printing operation, press **REC ON/OFF** and **ENTRY** simultaneously again.
- (5) When the message printing completes, your recorder returns to the normal operation.

* With this procedure, the printing operation turns off. Press **REC ON/OFF** and then press **ENTRY** again to turn it on.

Remarks

Message printing cannot be executed in the following conditions.

- (1) **RECORD ON** status lamp is not lit.
- (2) **KEY LOCK** status lamp lights.
- (3) For the chart speed programmed at 150 mm/h or faster

Reference

Execution with external contact signal

When the remote contacts (option) is added, message printing can also be executed by a contact signal. However, this requires the programming of the "terminal allocation". See Section 13.2 for details.

Example of message printing

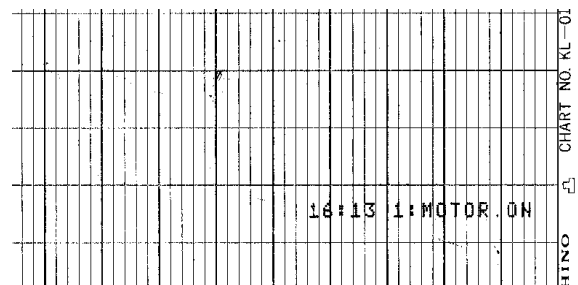

(Note) The above example is for AL3000. It is the same for AH3000.

9. PRINTING

9.5 Printing Format Selection

This selection is only applicable to the printing format function (option). Four types of analog printing format are available.

1 Types of Printing Format

Before the selection, the programming of the desired format is required. See Section 14.
The default is the standard format (S d).

Types of format and programming

Types	Programming
(1) Standard (S d)	Not required
(2) Automatic range shift (R r)	Section 14.1
(3) Compressed/expanded (S P)	Section 14.2
(4) Zone (P L)	Section 14.3

2 Selection Flow Chart

<Example> From Standard printing to Zone printing

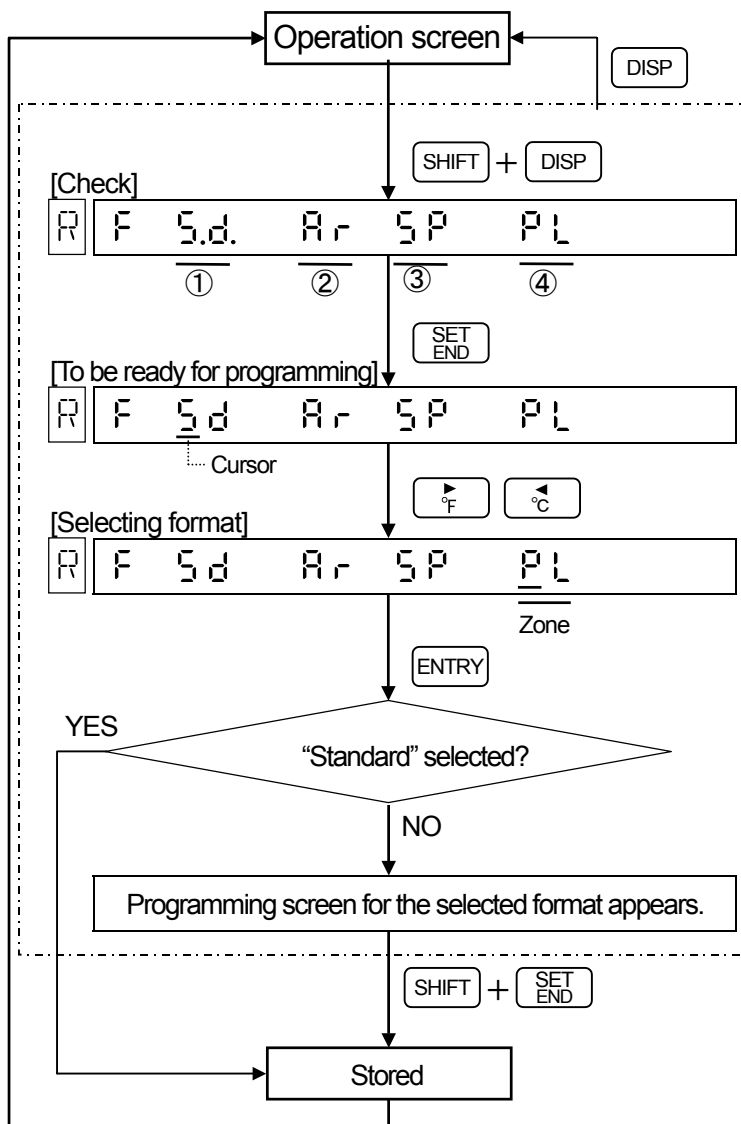

Reference 1 Printing format check

Decimal point appears in the current format.

- (1) S d : Standard
- (2) R r : Automatic range shift
- (3) S P : Compressed/expanded
- (4) P L : Zone

Reference 2 Storing procedure

1. To store the standard format; Press **ENTRY** key.
2. To store the format other than the standard: Press **ENTRY** and then press **SHIFT** and **SET END** simultaneously.

Reference 3 Storing

The selected format is stored into memory. The trace printing is executed in the stored format. (Programming change mark \triangle is printed.)

1 Time Axis Synchronization (POC)

- (1) This function is applicable to 2-pen, 3-pen and 4-pen types. In the standard printings, data at the same moment are printed on the chart paper with time axis gaps due to the difference in pen positions between 1st pen and 2nd to 4th pens. (When POC = OFF)
- (2) The time axis synchronization functions to store the data of 2nd to 4th pens for the gaps and to print the stored data after the chart paper is fed to the printing start point of the 1st pen. (When POC = ON)
- (3) The time axis synchronization is not available in 1-pen types.

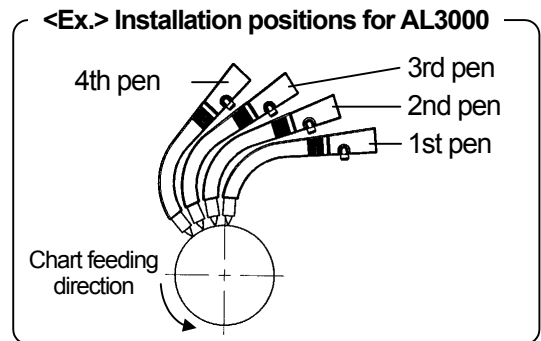

2 Flow Chart for Selecting Time Axis Synchronization

<Example> From time axis synchronization Off to On

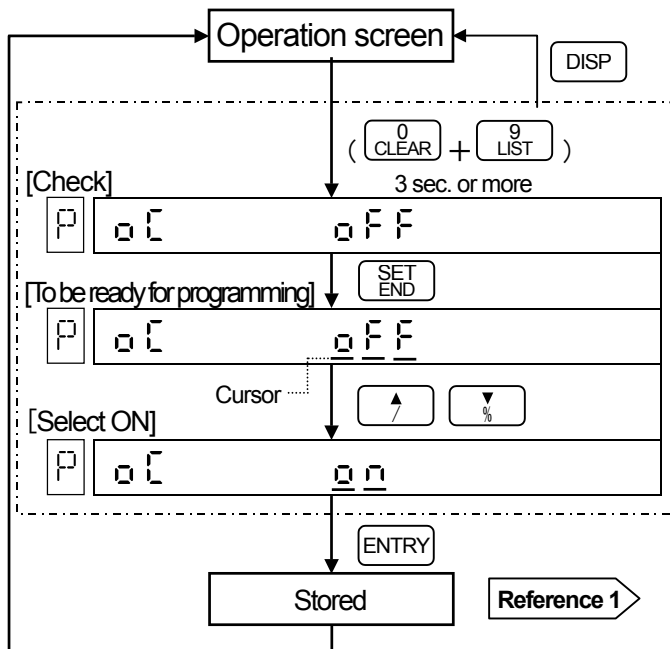

Reference 1 Storing

Selected time axis synchronization (on or off) is stored into memory. (Programming change mark \triangle is printed.)

Reference 2 Time axis synchronization mark

A marking as shown below is printed when the time axis synchronization is switched to on or off.

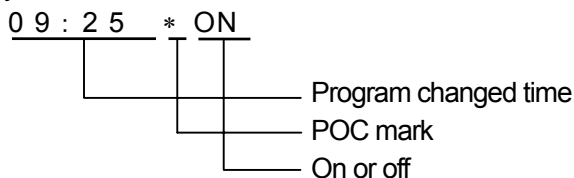

<Printing EX. 1> Time axis synchronization not executed

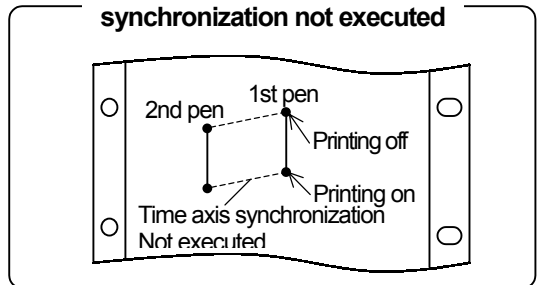

<Printing EX. 2> Time axis synchronization executed

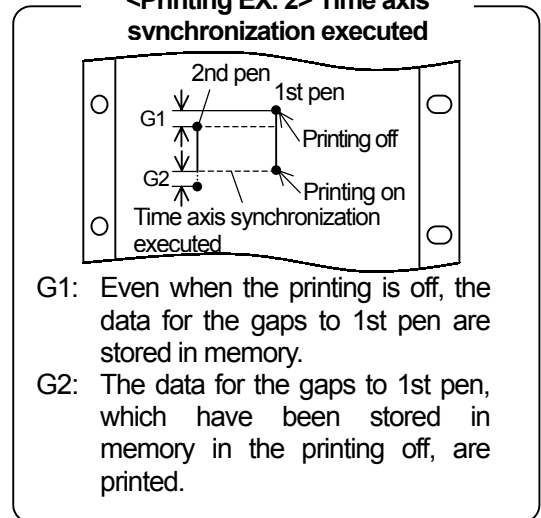

<Printing EX. 3> Power supply on/off

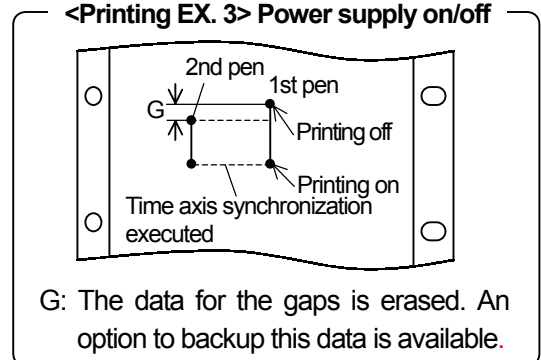

10. OPERATIONS

10.1 Fixed-Time Printing and Intervals

After your recorder is turned on, parameters including time, chart speed and scale are printed at specified intervals. The place of printing is in principle on the left side of the chart paper.

Printing items	Printing intervals, etc.																								
1. Year/Month/Day, Time	When power or printing is switched on <Ex.> 2000.10.03.14:25* (*: Only when time axis synchronization is on)																								
2. Year/Month/Day	24-hour period (Printing every 00 hour 00 minute) <Ex.> 2000.10.04																								
3. Chart speed	Approx. 84 mm intervals <Ex.> 20 mm/h																								
4. Scale 5. Engineering unit 6. Tag (Note) (Note) For only channels being programmed	<p>Approx. 42 mm intervals, in order of channel No. When the printing format (option) is added, the printing contents vary depending on the selected format as shown in the following examples. When the printing format is not added (standard), the printing is as shown in (1).</p> <table border="1"> <tr> <td>(1) Standard (Sd)</td> <td>(2) Automatic range shift (Ar)</td> </tr> <tr> <td> <p>Channel 1:TIC1 Tag 0.0/500.0°C Engineering unit Scale</p> </td> <td> <p>1: TIC1 0.0/500.0°C (Note) In 5 ranges (R1 to R5), the range when the printing is being executed is printed as the scale.</p> </td> </tr> <tr> <td>(3) Compressed/expanded (SP)</td> <td>(4) Zone record (PL)</td> </tr> <tr> <td> <p>1:TIC1 0.0/200.0/400.0/500.0°C Zero 1st break point 2nd break point Span</p> </td> <td> <p>1:TIC1 0.0/500.0°C *: The "+" marking identifying zones is printed at its boundary.</p> </td> </tr> </table> <p>* The "+" mark is printed at the positions of break points 1 and 2.</p>	(1) Standard (Sd)	(2) Automatic range shift (Ar)	<p>Channel 1:TIC1 Tag 0.0/500.0°C Engineering unit Scale</p>	<p>1: TIC1 0.0/500.0°C (Note) In 5 ranges (R1 to R5), the range when the printing is being executed is printed as the scale.</p>	(3) Compressed/expanded (SP)	(4) Zone record (PL)	<p>1:TIC1 0.0/200.0/400.0/500.0°C Zero 1st break point 2nd break point Span</p>	<p>1:TIC1 0.0/500.0°C *: The "+" marking identifying zones is printed at its boundary.</p>																
(1) Standard (Sd)	(2) Automatic range shift (Ar)																								
<p>Channel 1:TIC1 Tag 0.0/500.0°C Engineering unit Scale</p>	<p>1: TIC1 0.0/500.0°C (Note) In 5 ranges (R1 to R5), the range when the printing is being executed is printed as the scale.</p>																								
(3) Compressed/expanded (SP)	(4) Zone record (PL)																								
<p>1:TIC1 0.0/200.0/400.0/500.0°C Zero 1st break point 2nd break point Span</p>	<p>1:TIC1 0.0/500.0°C *: The "+" marking identifying zones is printed at its boundary.</p>																								
7. Time line 8. Time	<p>Printing of "time line" and "time" is interlocked with chart speed and is executed at the following intervals. The start point of intervals is 00:00 hours.</p> <table border="1"> <thead> <tr> <th>Chart speed (mm/h)</th> <th>Time line</th> <th>Time</th> </tr> </thead> <tbody> <tr> <td>1 to 9</td> <td>6 hours</td> <td>12:00 only</td> </tr> <tr> <td>10 to 15</td> <td>2 hours</td> <td>4 hours</td> </tr> <tr> <td>16 to 30</td> <td>1 hour</td> <td>2 hours</td> </tr> <tr> <td>31 to 60</td> <td>1 hour</td> <td>1 hour</td> </tr> <tr> <td>61 to 119</td> <td>30 minutes</td> <td>1 hour</td> </tr> <tr> <td>120 to 149</td> <td>30 minutes</td> <td>30 minutes</td> </tr> <tr> <td>150 or faster</td> <td>30 minutes</td> <td>No printing</td> </tr> </tbody> </table> <p><Example> ① Time line ② Time ③ POC mark (Note: Printed only when the time axis synchronization is on)</p> <p>(Note) See Section 9.6 for details.</p>	Chart speed (mm/h)	Time line	Time	1 to 9	6 hours	12:00 only	10 to 15	2 hours	4 hours	16 to 30	1 hour	2 hours	31 to 60	1 hour	1 hour	61 to 119	30 minutes	1 hour	120 to 149	30 minutes	30 minutes	150 or faster	30 minutes	No printing
Chart speed (mm/h)	Time line	Time																							
1 to 9	6 hours	12:00 only																							
10 to 15	2 hours	4 hours																							
16 to 30	1 hour	2 hours																							
31 to 60	1 hour	1 hour																							
61 to 119	30 minutes	1 hour																							
120 to 149	30 minutes	30 minutes																							
150 or faster	30 minutes	No printing																							

Reference

When the chart speed is 150 mm/h or faster

No printing is executed except time line, data and programming change mark.

10. OPERATIONS

10.2 Operations at Abnormal Inputs

1 Over-range input

The following table shows displays and printings for input exceeding a printing range or a measuring range.

- Measuring range:
Determined by the range No. programmed in "Range/Printing range". See Section 8.2.
- Printing range:
Trace printing range programmed in "Range/Printing range".

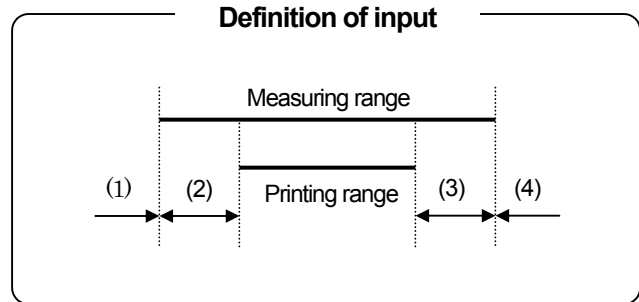

区分	Input	Display		Printing	
		Digital	Bar graph	Digital	Analog
(1)	Lower than minimum measuring range*	— — — — —	□□□·……·□□□ (All go off.)	— — — — —	Overshooting to minimum limit
(2)	Lower than minimum printing range	Normal	□□□·……·□□□ (All go off.)	Normal	
(3)	Higher than maximum printing range	Normal	■ ■ ■ ·……· ■ ■ ■ (All light.)	Normal	Overshooting to maximum limit
(4)	Higher than maximum measuring range*	— — — — —	■ ■ ■ ·……· ■ ■ ■ (All light.)	+ — — — —	

* For the digital display and printing, the measured values can be displayed and printed up to about $\pm 10\%$ of the span even when the values are outside the measuring range.

2 Input Disconnection

The display and printing, when the input is disconnected, differ depending on the "Burnout enable/disable" programming. However, for channels of a voltage (mV or V) range, the burnout function is "disable (non)" even when "Burnout Enable/Disable" is programmed. Program "Burnout enable/disable" to each channel. See Section 11.11.

Programming burnout	Display		Printing	
	Digital	Bar graph	Digital	Analog
Disable (non)	Undefined	Undefined	Undefined	Undefined
Enable - downscale (doWn bUm)	b U r n	□□□·……·□□□ (All go off.)	BURN	Overshooting to minimum limit
Enable - upscale (UP bUm)	b U r n	■ ■ ■ ·……· ■ ■ ■ (All lights.)	BURN	Overshooting to maximum limit

10. OPERATIONS

10.3 Alarm Display and Printing

1 Display of Alarm Activation

The alarm activation information can be checked in the operation screen.

1) Measured value display screen

<Ex.> Alarm activated at CH 1 in 3-pen type

(1) ALARM

(2)

(Note) The above example is for AL3000. It is the same for AH3000.

Display in case alarm activated

- (1) **ALARM** status lamp lights.
- (2) The measured value of the channel in alarm blinks.

(To cancel blinking)
Press **ENTRY**. The measured value is displayed steadily.

2) Alarm display screen

<Ex.> Alarm activated at CH 1 in 3-pen type

(1) A H

(2)

(3) ALARM

(Note) The above example is for AL3000. It is the same for AH3000.

Display in case of alarm activated

- (1) The character display shows "A".
- (2) The alarm type at the level, of which the alarm is activated, is displayed for each channel.
- (3) **ALARM** status lamp lights.

(Note) If no alarm activates, the alarm display screen is not displayed even when **DISP** is pressed.

2 Alarm Activation/Reset Printing

Alarm activation and reset are printed on the right side of the chart paper.

1) Printing format when an alarm activates

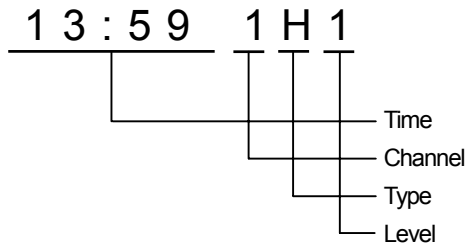

2) Printing format when an alarm is reset

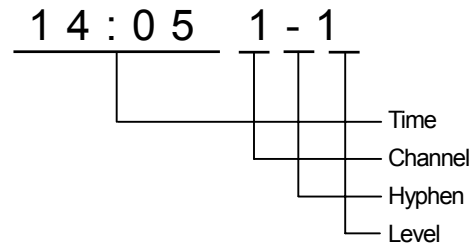

Printing example of alarm activation

Printing example of alarm reset

11. OTHER PROGRAMMING

11.1 Time

For programming date and time, press **SHIFT** and **CLOCK** simultaneously to display the "Clock" programming screen. The default is Japanese time.

1 Programming Mode

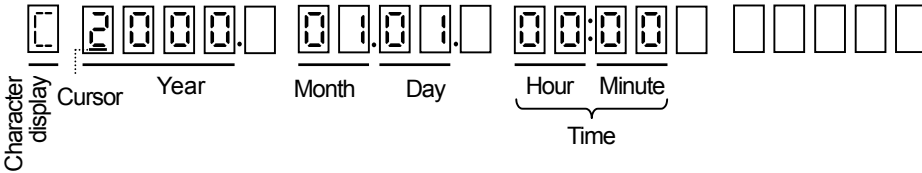

2 Programming Flow Chart

<Example> From 00:00 hours on January 1st, 2000 to 15:40 hours on October 19th, 2000

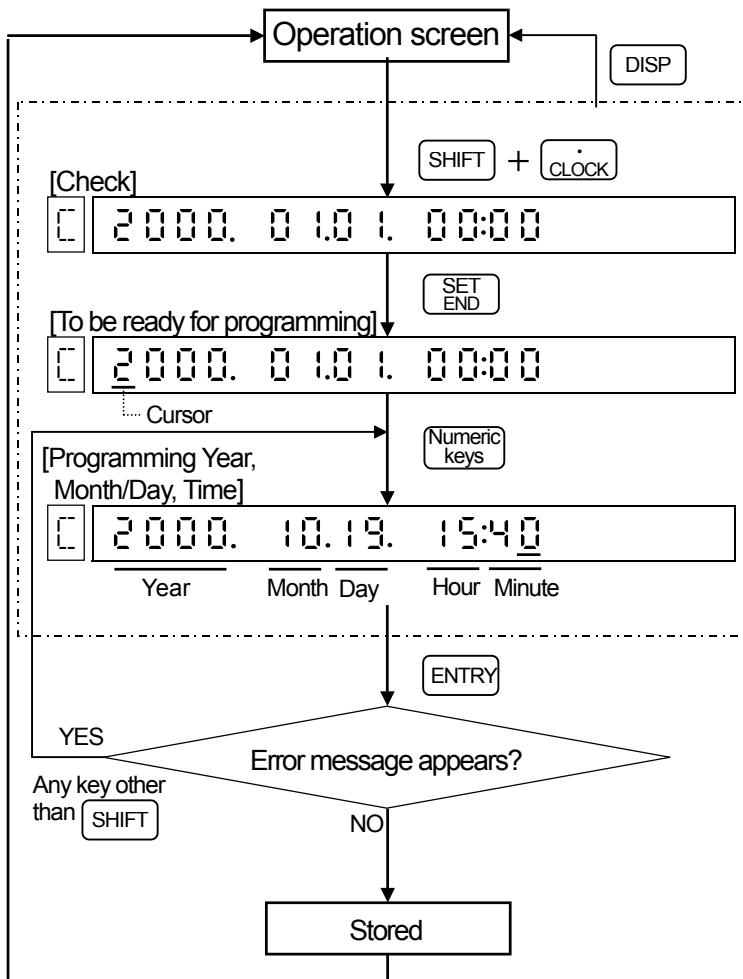

Clock circuit

Clock data is maintained with a lithium battery. The clock keeps on working during the time that the power supply is off or if the power supply is interrupted. The service life of the battery is for eight years under the condition of eight hours operation in a day.

Reference 1 Time display during programming

Time display stops during programming. Press **ENTRY** to start the display again.

Reference 2 Programming time

The time is programmed with a 24-hour display, which means that the programming range is 00:00 to 23:59.

11. OTHER PROGRAMMING

11.2 Scale

“Scale” programming is necessary to display a voltage input from a converter, etc. with an actual scale. However, the scale is programmed with the same characteristic scale (not linearized scale) as the voltage input. This programming is also necessary when the decimal point position is changed in thermocouple or resistance thermometer input channels. Press **SHIFT** and **SCALE** simultaneously in the operation screen to display the “scale” programming.

1 Programming Scale

This is the actual scale (physical quantity) programming for the printing range being programmed in the [Range/Printing range].

2 Printing range will be copied

When programming the [Range/Printing range], the printing range is copied to the programming value of the scale.

If the scale copied from the printing range is used, the decimal point positions programmed by the printing range are neglected and the measured values with decimal point positions fixed by range number are displayed. The following table shows the cautions to be observed according to the input types.

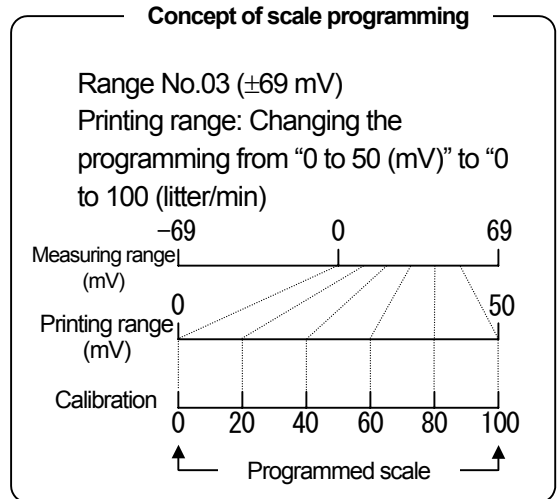

Voltage ranges	Temperature ranges
Scale programming is not required when the scale is equal to the printing range. They are copied to scale programming, but be careful with the decimal point positions for the scale. See item 3 .	Since the printing range is copied to the scale, no programming scale is necessary, but the decimal point position of the measured value is fixed by the range number. For changing the decimal places, refer to 3 .

3 Example of Decimal Point Programming

Voltage range	Temperature ranges																																					
<p>(1) When the printing range is equal to the scale;</p> <table border="1"> <thead> <tr> <th>Range/Printing range</th> <th>Scale programming</th> <th>An example of measured values</th> <th>Notes</th> </tr> </thead> <tbody> <tr> <td rowspan="2">03/0.0 to 50.0</td> <td>0.0 to 50.0</td> <td>5.00</td> <td>1</td> </tr> <tr> <td>0 to 50</td> <td>5</td> <td rowspan="2">2</td> </tr> <tr> <td>03/0 to 50</td> <td>0.0 to 50.0</td> <td>5.0</td> </tr> </tbody> </table> <p>Note 1: Decimal point position of the measured value is fixed by range number when the printing range is equal to the scale. Note 2: Decimal point positions of the programmed scale become effective because different decimal place are programmed on printing range and scale. See item (2).</p> <p>(2) When the scale is programmed with a different value from the printing range. The decimal point position of the programmed scale becomes effective.</p>	Range/Printing range	Scale programming	An example of measured values	Notes	03/0.0 to 50.0	0.0 to 50.0	5.00	1	0 to 50	5	2	03/0 to 50	0.0 to 50.0	5.0	<p>(1) To move the decimal point to higher digit</p> <table border="1"> <thead> <tr> <th>Range/Printing range</th> <th>Scale programming</th> <th>An example of measured values</th> <th>Notes</th> </tr> </thead> <tbody> <tr> <td>23/0 to 1200</td> <td>0.0 to 1200.0</td> <td>850.0</td> <td></td> </tr> <tr> <td>230.0 to 1200.0</td> <td>0.0 to 1200.0</td> <td>850</td> <td>1</td> </tr> </tbody> </table> <p>Note 1: Decimal point position of the measured value is fixed by range number when the printing range is equal to the scale.</p> <p>(2) To move the decimal point to lower digit</p> <table border="1"> <thead> <tr> <th>Range/Printing range</th> <th>Scale programming</th> <th>An example of measured values</th> <th>Notes</th> </tr> </thead> <tbody> <tr> <td rowspan="2">25/0 to 200</td> <td>0 to 200</td> <td>120.0</td> <td></td> </tr> <tr> <td>0 to 200.0</td> <td>120</td> <td>1</td> </tr> </tbody> </table> <p>Note 1: Due to the decimal point position rule. Remarks</p>	Range/Printing range	Scale programming	An example of measured values	Notes	23/0 to 1200	0.0 to 1200.0	850.0		230.0 to 1200.0	0.0 to 1200.0	850	1	Range/Printing range	Scale programming	An example of measured values	Notes	25/0 to 200	0 to 200	120.0		0 to 200.0	120	1
Range/Printing range	Scale programming	An example of measured values	Notes																																			
03/0.0 to 50.0	0.0 to 50.0	5.00	1																																			
	0 to 50	5	2																																			
03/0 to 50	0.0 to 50.0	5.0																																				
Range/Printing range	Scale programming	An example of measured values	Notes																																			
23/0 to 1200	0.0 to 1200.0	850.0																																				
230.0 to 1200.0	0.0 to 1200.0	850	1																																			
Range/Printing range	Scale programming	An example of measured values	Notes																																			
25/0 to 200	0 to 200	120.0																																				
	0 to 200.0	120	1																																			

Remarks **Decimal point position rule.**
 If the decimal point positions of the lower-limit and higher-limit values are different, the lower decimal point position is adopted. <Example> 0.00 to 100.0 \Rightarrow 0.0 to 100.0

Remarks **For programming the same scale to the other channels;**
 The [Copy] function is convenient. See Section 11.14.

11. OTHER PROGRAMMING | 11.2 Scale

4 Programming Mode

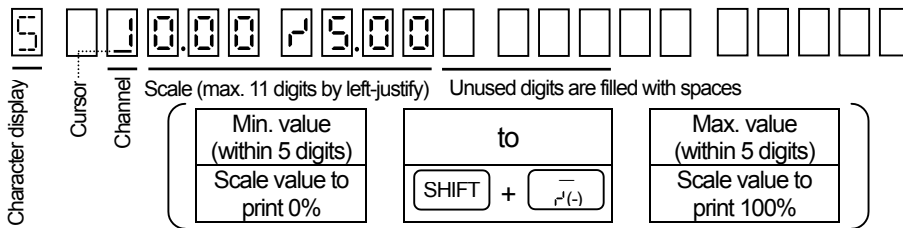

5 Programming Flow Chart

<Example> -100 to +100 for CH 3

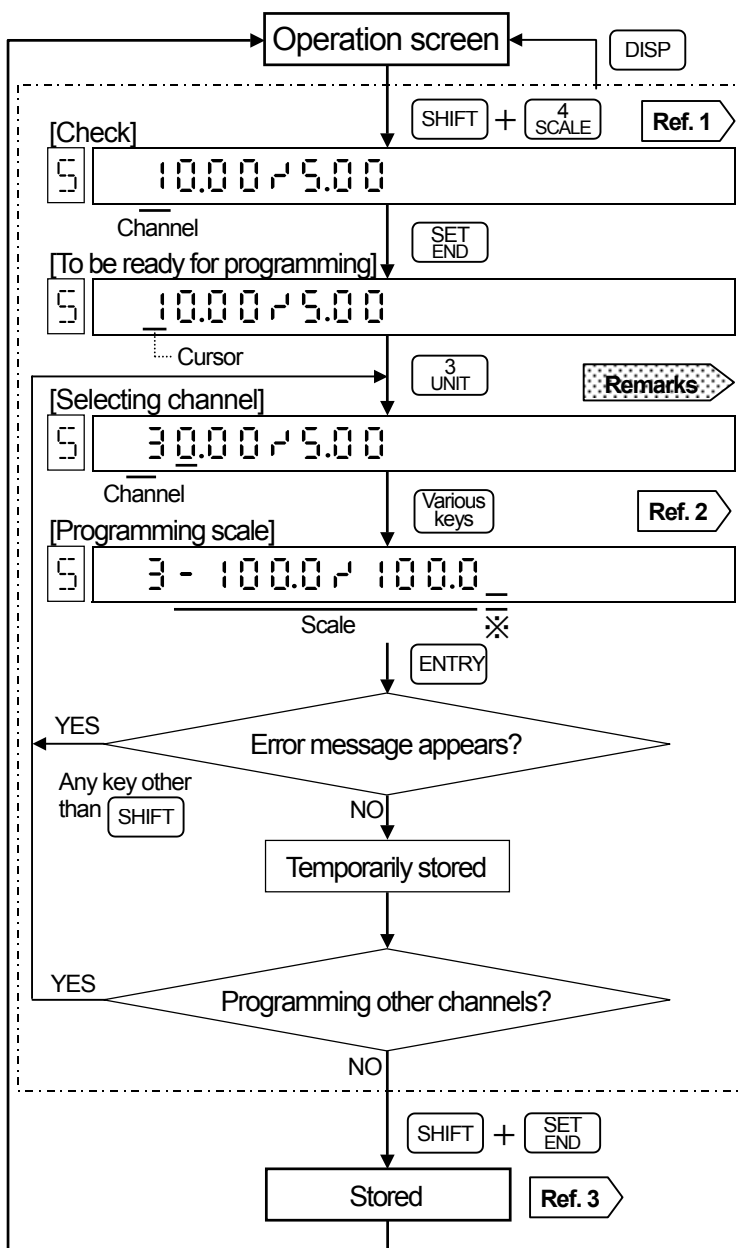

Remarks To clear (none) the scale programmed

- (1) Select the channel to program to "none" with \uparrow or \downarrow .*
- (2) Press **SHIFT** and **0 CLEAR** simultaneously to clear and execute [temporarily storing] and [storing].

* If a channel is programmed by a numeric value, not by up and down keys, and cleared, the channel before programming change is programmed to scale "none".

Note) The scale of the channel, of which scale was programmed to "none", is reflected by the printing range being programmed in the [Range/Printing range]. Tag and alarms are cleared (not programmed).

Reference 1 Other channels check

Press \uparrow or \downarrow to check the programmed scale of other channels.

Reference 2 Various keys

- Adding/deleting decimal point
Move the cursor to the right:
 $\dot{\text{CLOCK}}$ or $\frac{\text{SPACE}}{\text{COPY(=)}} \rightarrow$ Numeric keys
- Programming "to": **SHIFT** + $\dot{\text{(-)}}$
- Space: $\frac{\text{SPACE}}{\text{COPY(=)}}$

Reference 3 Storing

Store the [temporarily stored] parameters into the memory. (A programming change mark is printed.)

* Fill unused digits with spaces.

11. OTHER PROGRAMMING 11.3 Skip (Channel Deletion)

When "CLEAR" (non-programming condition) is stored in the [Range/Printing range] programming, printing and display of specific channels are skipped. Press **SHIFT** and **7 RANGE** in the operation screen to display the [Range/Printing range] programming screen. The default is no skip function programmed to any channel.

1 Skipping

If the skip function is programmed to the specified channel, programmed parameters of [scale], [alarm], [engineering unit] and [tag] of this channel are also cleared. Program the parameters again if the channels are restored to no-skipped status.

Operation of skipped channels

Your recorder functions assuming that these channels do not exist.

- (1) Measured value: Disappear
- (2) Bargraph: Disappear
- (3) Data printing: Disable
- (4) Trace printing: Overshooting to the minimum limit.

2 Programming Skip Flow Chart

<Example> Skipping CH 3 (3rd pen)

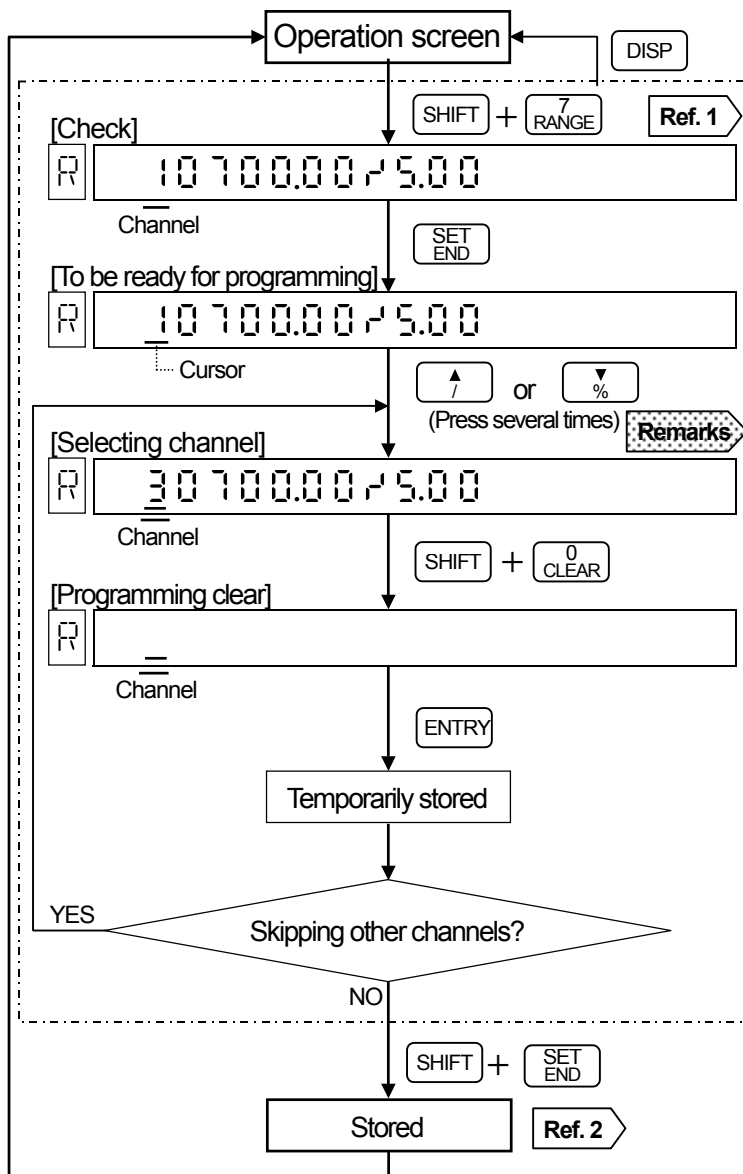

Remarks To select channels

Select a channel with **↑** or **↓**.
If a channel is selected with a numeric key and the "CLEAR" is executed, the channel being displayed before changing programming ([1] in the flow chart) is deleted.

Reference 1 Other channel check

You can check the range programming of other channels. Press **↑** or **↓** to change channels. The skipped channels are not displayed.

Reference 2 Storing

Store the [temporarily stored] skip into the memory. (A programming change mark is printed.)

3 New Programming Flow Chart of Skipped Channel

<Example> To the range of 0 to 1200 °C (K) for skipped channel (CH 3)

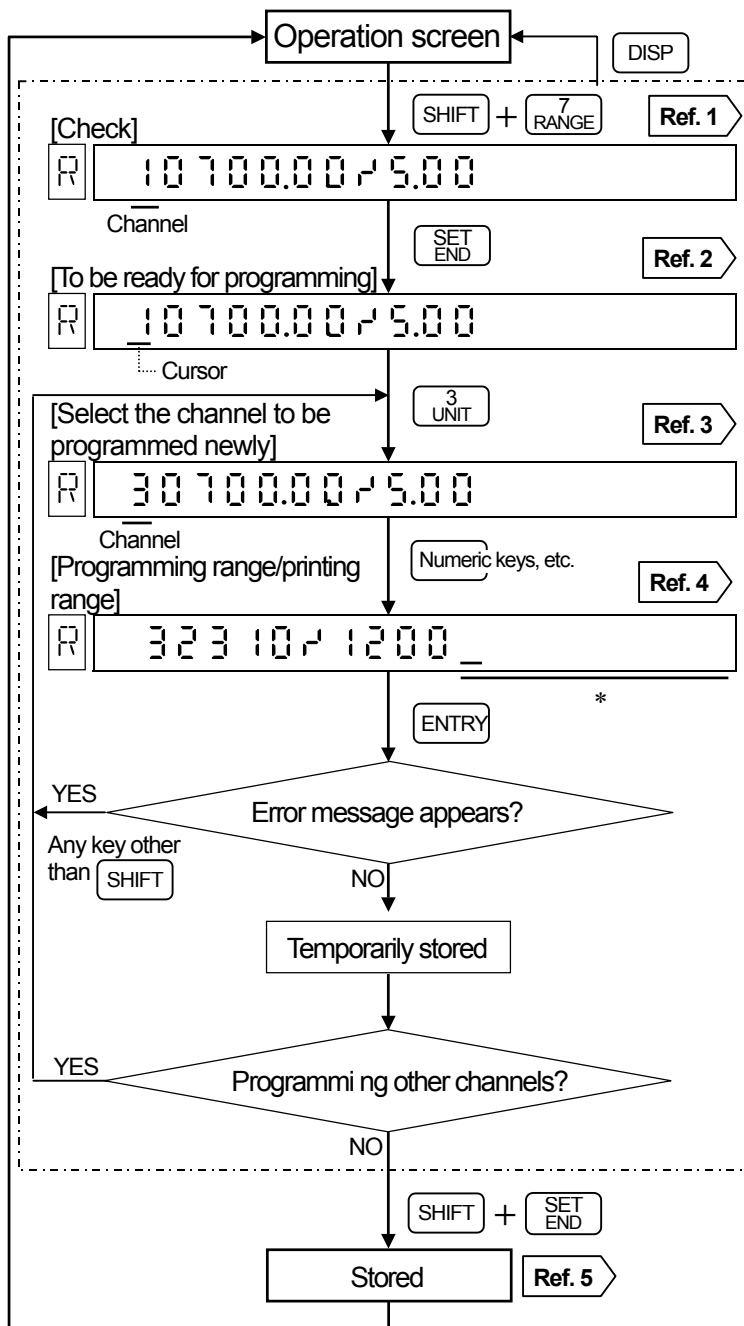

Other programming parameters

The programmed parameters of [scale], [alarm], [engineering unit] and [tag] are cleared at the skipped channels.

- 1) Select a computing unit in the [°C/°F computing selection] if the channels are newly programmed to temperature range.
- 2) Program the required [scale] if the channels are newly programmed to voltage range.
- 3) Program [alarm], [engineering unit] and [tag] if necessary.

Reference 1 Skipped channel check

You can check the range programming of other channels. Press or to change channels. The skipped channels are not displayed.

Reference 2 Starting channel

This programming can be started at any channel. With the example flow chart, the programming starts from CH 1. As the programmed parameters of CH 1 are not changed, they are same as original parameters.

Reference 3 Channel No. for new programming

In the example, CH 3 is a channel to be newly programmed. If CH 3 has not been programmed as a skip channel, new range/printing range is displayed.

Reference 4 Range/Printing range programming

Refer to Section 8.2.

Reference 5 Storing

Store the [temporarily stored] parameters into the memory. (A programming change mark is printed.)

* Fill used digits with spaces.

11. OTHER PROGRAMMING

11.4 Subtract Printing

This programming is for printing a difference between channels or between a channel and a reference value. Press **[SHIFT]** and **[RANGE]** simultaneously to display the [Range/Printing range] programming screen to program the subtract printing.

1 Subtract Printing Types

Two types of subtract printings are provided.

- (1) Printing a difference between a reference channel and a subtraction channel
- (2) Printing a difference between a reference channel and a specified subtraction value (reference value).

Remarks 1 Programming reference channel and subtraction channel

Be sure to program [Range/Printing range] of both the reference channel and the subtraction channel in advance.

Remarks 2 Place a decimal point to the reference value

Program the reference value with the scale programmed value within 5 digits. For identifying the reference value to a channel No., be sure to place a decimal point to the reference value having no decimal point.

<Ex. 2 → 2.0>

Subtract printing channel

Subtract printing can be specified to any channel. For example, [CH 1 minus CH 2] can be specified to [CH 2]. In this case, the difference between channels are displayed and printed at CH 2.

Concept of subtract printing

<Example> Printing the difference between CH 1 and CH 2 at CH 3

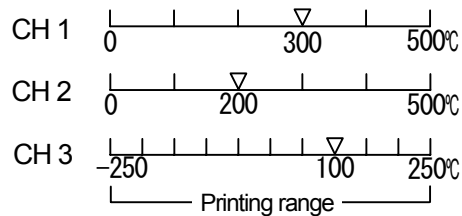

2 Programming Modes

1) Mode 1

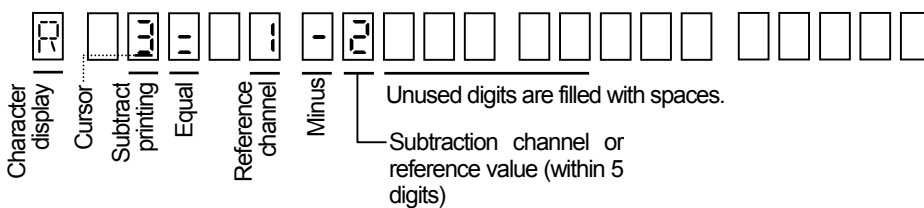

Character display

Programming lamp
"R" stands for the subtract printing mode 1.

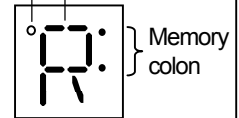

2) Mode 2 (To move from Mode 1 to Mode 2, press **[ENTRY]** after completing the programming for the Mode 1.)

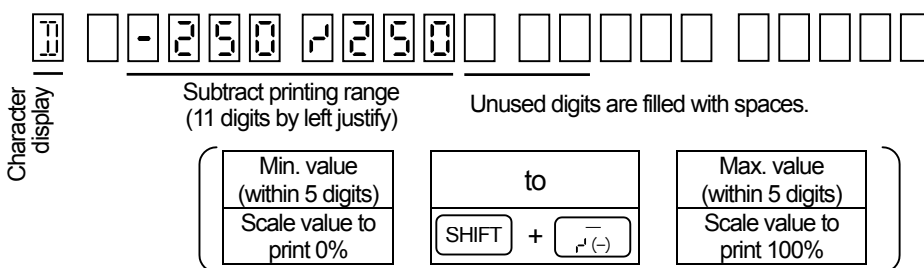

Character display

Programming lamp
"D" stands for the subtract printing mode 2.

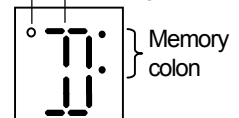

3 Programming Flow Chart

<Example> Printing [Channel 1 – Channel 2] at Channel 3 within a printing range of ±250

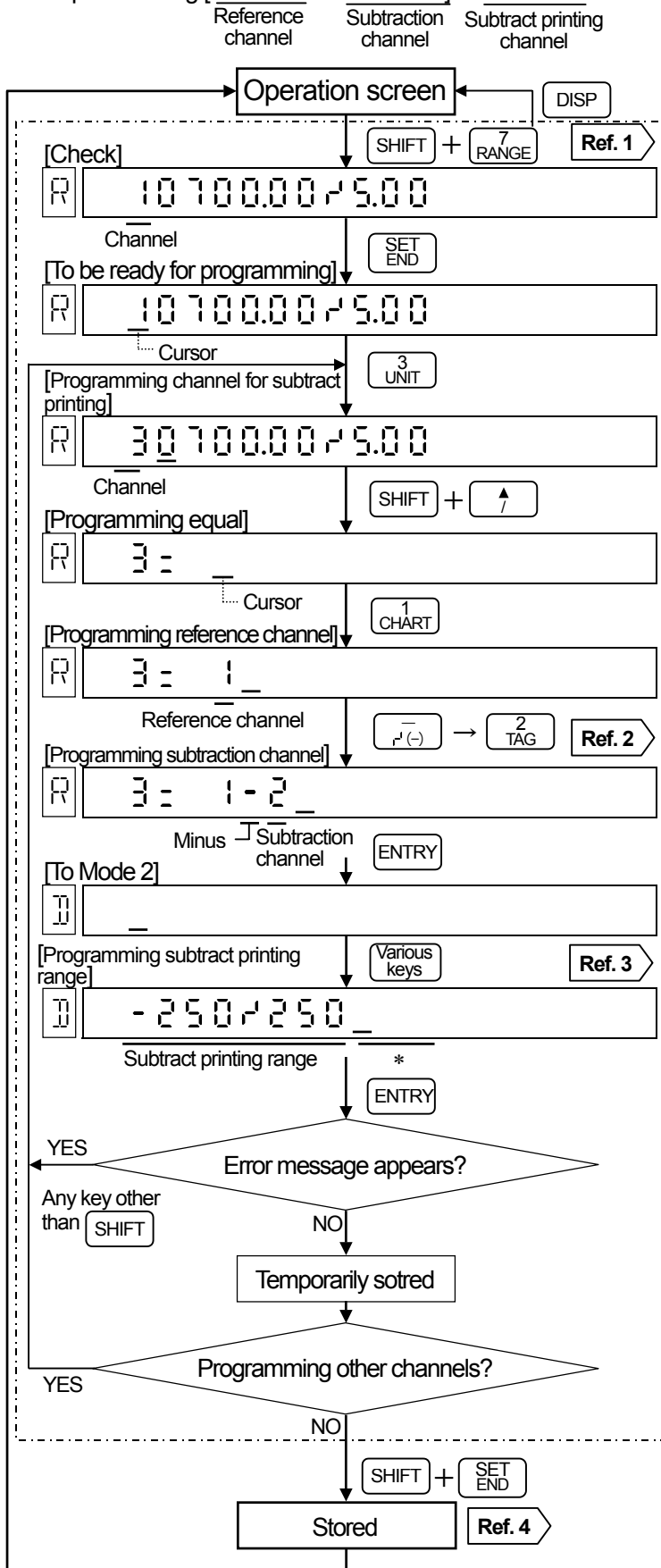

Reference 1 Other channels check

You can check the range programming (including subtract printing) of other channels. Press \uparrow or \downarrow to change channels..

Reference 2 Programming reference channel and subtraction channel

If a specified value (reference value) is programmed instead of the subtraction channel in the flow chart, the difference with the reference value will be printed. Add a decimal point to the reference value.

Reference 3 Various keys

- Programming "to": $\text{SHIFT} + \text{r}(-)$
- Decimal point: CLOCK in the next digit
- Deletion of decimal point: $\text{SPACE COPY}(=)$ in the next digit

Reference 3 Storing

Store the [temporarily stored] parameters into the memory. (A programming change mark is printed.)

* Fill unused digits with spaces.

11. OTHER PROGRAMMING

11.5 Alarm

Alarm parameters (alarm types, alarm value, etc.) can be programmed for each alarm point (channel, level). By programming the alarm parameters, alarm activation can be displayed and also the activation and reset can be printed. See Section 10.3. Press **[SHIFT]** and **[ALARM]** simultaneously to display the [Alarm] programming screen. Alarm output is an option. The alarm outputs for "FAiL (failure)" and "C. End (chart paper end)" are available in addition to measured values.

1 Alarm Parameters

The default is no alarm programmed.

1) Alarm points (Channel, level)

Alarm point can be programmed up to level 4 for each channel. "FAiL" and "C. End" can be programmed instead of the channels.

FAiL...Alarm when the hardware except servo-circuit/mechanism is abnormal
In this condition, the status lamp is not lit.

C. End...Alarm at just before when the chart paper ends.

2) Alarm types

10 different alarm types can be selected for each alarm point.

Absolute value	H: High alarm	L: Low alarm
	E: High alarm with standby	F: Low alarm with standby
Rate-of-change	U: Increase limit	D: Decrease limit
Differential	b: Differential high alarm	c: Differential low alarm
	v: Differential high alarm with standby	w: Differential low alarm with standby

3) Alarm value

Value for alarm activation

2 Alarm Types

The high alarm for the absolute value activates when the measured value equals to or is higher than the alarm value. The low alarm activates when the measured value equals to or is lower than the alarm value.

For the rate-of-change alarm and the differential alarm, refer to the followings.

Rate-of-change alarm

Increase limit alarm: Change width (PV2 to PV1) per unit time (Δt) is plus.

Decrease limit alarm: Change width (PV2 to PV1) per unit time (Δt) is minus.

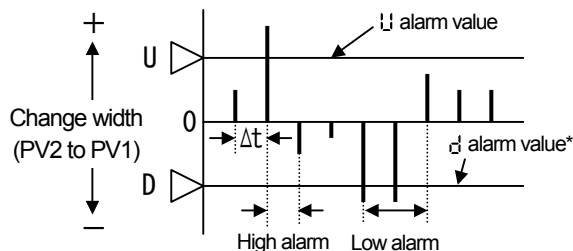

Unit time (Δt) = Measuring interval (about 0.1 sec.) x Measuring count (1 to 20)

* Do not apply a "minus" symbol to the alarm value of the decrease limit alarm (Δ).

4) Others

Rate-of-change alarm: Program measuring count (1 to 20)

Differential alarm: Program channels to be compared.

Relations between alarm parameters and alarm activation

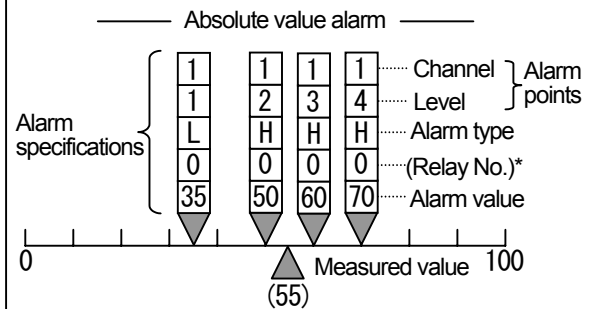

(1) The above figure shows programming alarm point up to level 4 on CH 1.

(2) Alarm is in active at level 2 (high alarm) as the measured value (55) is higher than the alarm value (50).

*No alarm output is provided to the standard specifications and the relay No. is fixed to "0". Refer to Section 12.2 for the programming of relay No.

Alarm with standby

This is the function not to activate an alarm until the alarm becomes in reset condition, even if the alarm is in active condition. This function is only available when the power supply is turned on. When changing parameters, this function is only available by reprogramming it after clearing once.

Differential alarm

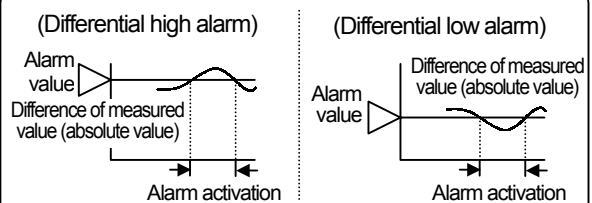

Difference of measured value (absolute value) equals to or is higher than alarm value: Differential high alarm activation
Difference of measured value (absolute value) equals to or is lower than alarm value: Differential low alarm activation

3 Programming Mode

1) Absolute value alarms (H, L, E, F)

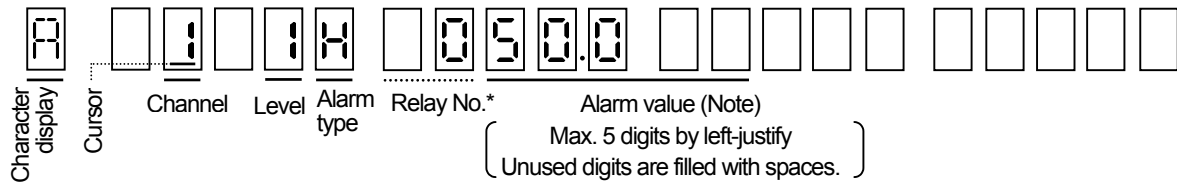

(Note) Program the alarm value within the scale range.

2) Range-of-change alarm (U, d)

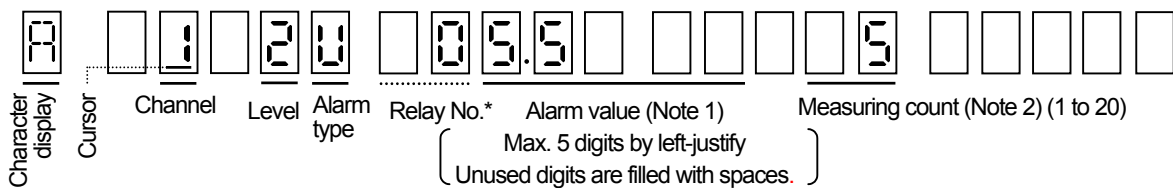

(Note 1) Program the alarm value with the change width (without sign) per unit time.

(Note 2) Unit time = measuring interval (about 0.1 sec.) x measuring count
 Program this measuring count (1 to 20).

3) Differential alarm (b, S, J, R)

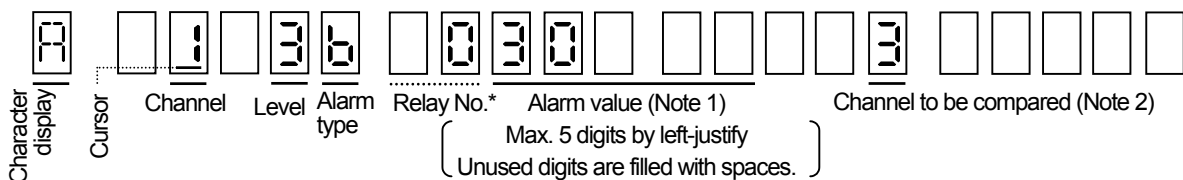

(Note 1) Program an alarm value with a difference (without sign) between measured values of channels.

(Note 2) Program another channel to be compared.

* In the standard specifications, the relay No. is fixed to "0" and the cursor does not appear. Program the relay No. for the alarm output (option) only. See Section 12.2.

4 Programming Flow Chart

1) Without alarm output (option)

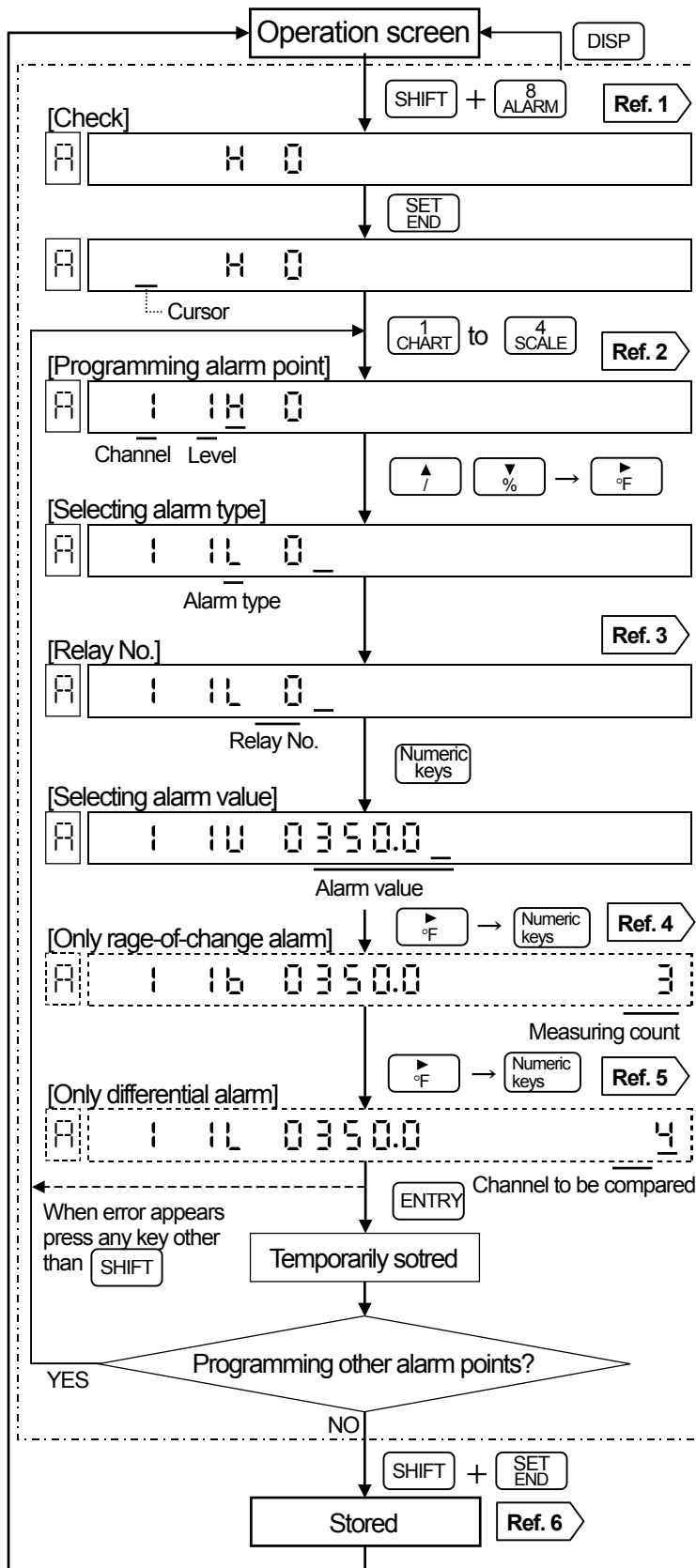

To delete an alarm point

Follow the [Programming alarm point] procedure and select the alarm point to be deleted with **↑**. Clear it by pressing **SHIFT** and **CLEAR** (0) simultaneously and perform [temporarily stored] and [stored] operation.

Reference 1 Other alarm point check

By pressing **↑**, the level advances from 1 to 4 and the channel advances to the next channel and then the level of the next channel advances. Press **↓** for reverse operation.

Reference 2 Programming alarm point

- Channel can be selected also with **↑** or **↓**.
- Channel advances by pressing **↑**. Then "Fail" and "C.End" appear but these functions are only available in the alarm output (option).

Reference 3 Relay No.

Relay No. is fixed to "0" and no cursor appears as the alarm output (option) is not added. The relay No. for AH is displayed with 2 digits of "00".

Cursor appears only for rate-of-change alarm.

Reference 4

Programming range is 1 to 20.

Cursor appears only for differential alarm.

Reference 5

Reference channel to be compared is programmed in 1 to 4. (The differential alarm cannot be selected in a 1-pen type recorder because no channel to be compared is existed.)

Reference 6 Storing

Store the [temporarily stored] parameters into the memory. (A programming change mark is printed.)

2) With alarm output (option)

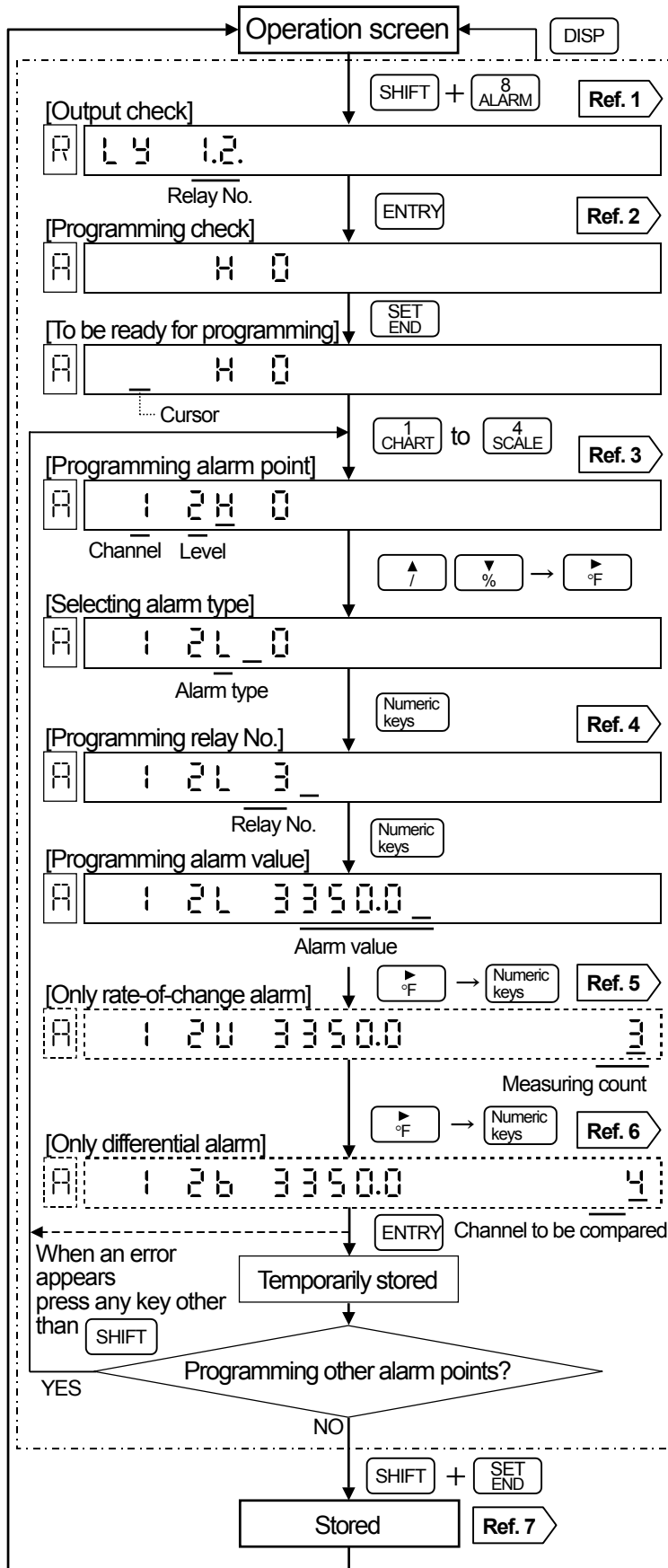

To delete alarm point

Follow the [Programming alarm point] procedure and select the alarm point to be deleted with . Clear it by pressing and simultaneously and perform [temporarily stored] and [stored] operation.

Reference 1 Output check

The relay Nos. in alarm output are displayed. This will be blank unless all of the relays are operated.

Reference 2 Other alarm point check

By pressing , the level advances from 1 to 4 and the channel advances to the next channel and then the level of the next channel advances. Press for reverse operation.

Reference 3 Programming alarm point

1. Channel can be selected also with or .
2. Channel advances by pressing . Then "Fail" and "C.End" appear. If these functions are selected, program relay Nos. only.

Reference 4 Relay No.

This is for specifying terminal Nos. for alarm output. The relay No. for AH is displayed with 2 digits such as "00". See Section 12.2. When programming "1" to "9", two entering methods of 1 to 9 or 01 to 09 are available. (: space)

Reference 5 Cursor appears only for rate-of-change alarm.

Programming range is 1 to 20.

Reference 6 Cursor appears only for differential alarm.

Reference channel to be compared is programmed in 1 to 4. (The differential alarm cannot be selected in a 1-pen type recorder because no channel to be compared is existed.)

Reference 7 Storing

Store the [temporarily stored] programmed values into the memory. (A programming change mark is printed.)

A deadband can be programmed between alarm-activation and alarm-reset.

Press **[SHIFT]** and **[°C]** simultaneously in the operation screen for 3 seconds or more to display the [Alarm deadband] programming screen. This programming is common to all alarm points.

1 Alarm Deadband

- An alarm activates when a measured value exceeds the alarm value. The alarm reset is executed at a value that is lower than the alarm value. This difference is called the deadband and is specified with a scale width (%).
- The programming range is 0.1 to 9.9% and can be programmed in 0.1% increments. The default is 0.1%.

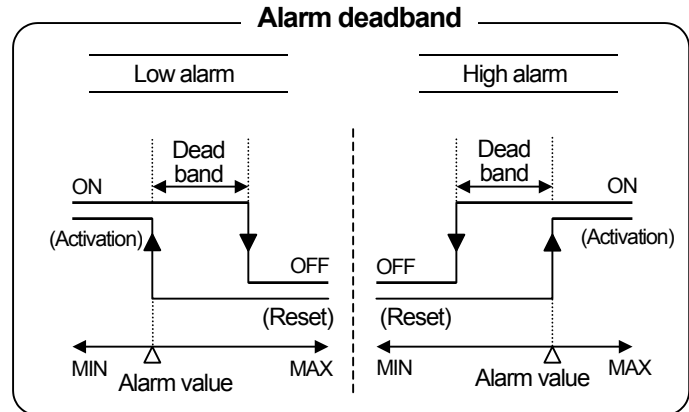

2 Programming Flow Chart

<Example> From 0.1% to 0.5%

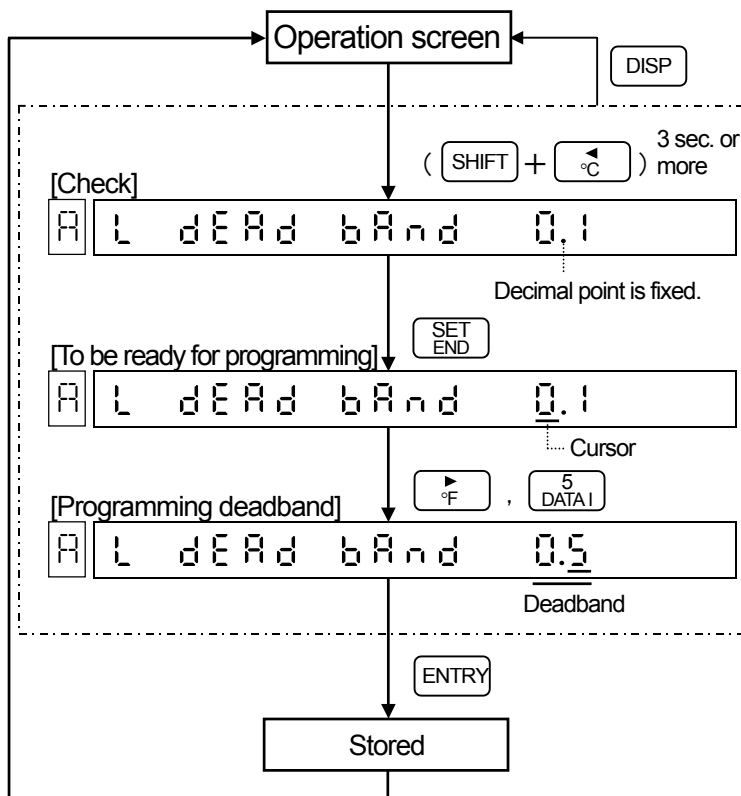

11. OTHER PROGRAMMING

11.7 Periodic Data Printing

This programming is for digital printing (data printing) at fixed intervals. The printing overlaps with trace printing. Press **SHIFT** and **DATA 5** simultaneously to display [Periodic data printing] screen. As the default is no programming of parameters for the periodic data printing, the periodic data printing is not executed.

1 Periodic Data Printing

- (1) Program start time and interval time.
- (2) The printing format with a chart speed of 99 mm/h or slower is shown below.

<Example> 18:30 1: 225°C 2: 316°C
Time

An example of periodic data printing (AL3000)

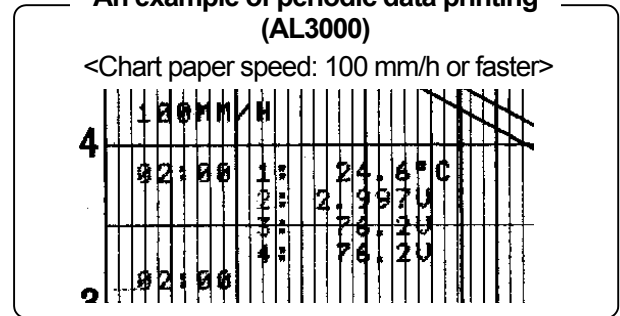

2 Programming Mode

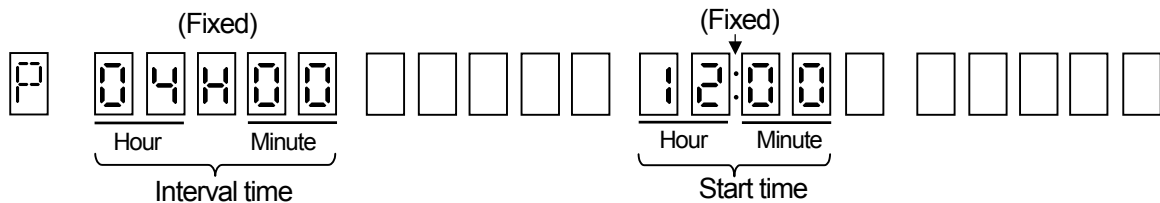

3 Programming Flow Chart

<Example> Periodic data printing with a start time of 12:00 and interval time of 4 hours

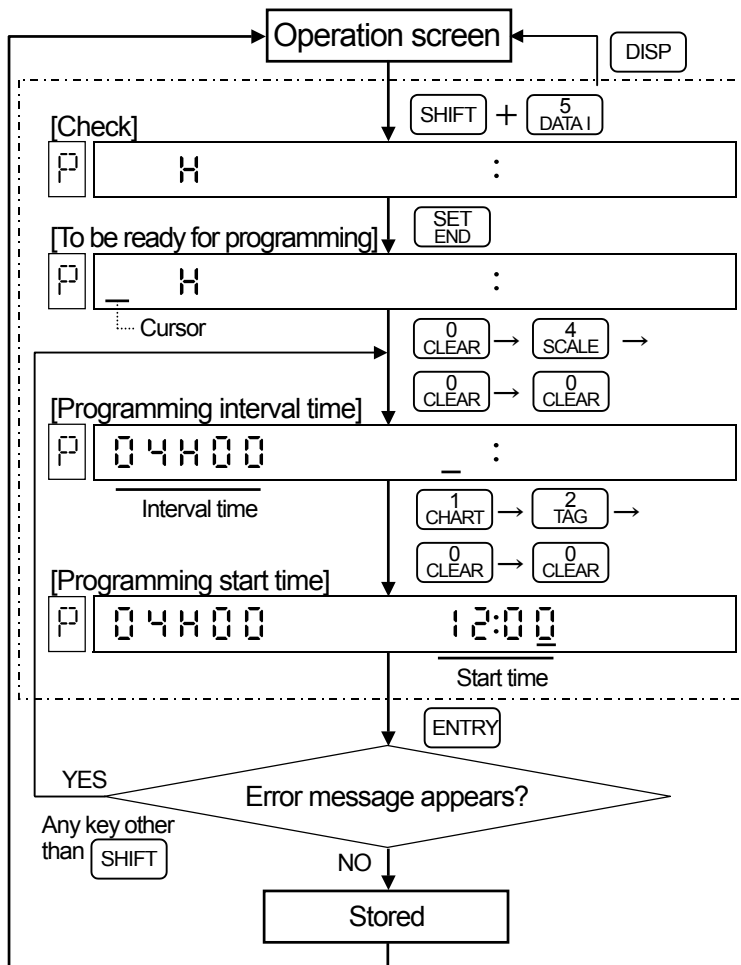

Remarks 1 Shortest time of interval time (T)

It depends on the chart speed and number of printing lines.

$$T (\text{Min.}) \geq \frac{180 \times \text{number of printing lines}^*}{\text{Chart speed} \times 1}$$

(Note) However, T is 5 minutes or more.

*1: When 3-speed is programmed by the remote contacts (option), the slowest speed is applied.

*2: Depending on the chart speed and number of channels.

Chart speed	CH1	CH2	CH3	CH4
99 mm/h or slower	1 line	2 lines		
100 mm/h or faster	1 line	2 lines	3 lines	4 lines

Remarks 2 To program periodic data printing to "none"

Press **SHIFT** and **CLEAR 0** simultaneously to clear and carry out [store].

Remarks 3 When the chart speed is changed;

The programmed values in the [Periodic data printing] are cleared and the periodic data printing stops. Reprogram it if necessary.

Remarks 4 From power off to on

In case electric power failure occurs and the power is turned on in the following day, reprogramming is required if $\frac{24}{T}$ is not an integer. (T: Interval time)

11. OTHER PROGRAMMING

11.8 Engineering Units

Engineering units up to 5 digits can be assigned for digital data printing and scale printing.
 Press **SHIFT** and **UNIT** simultaneously to display [Engineering unit] programming screen.

Examples of engineering unit printing

(Digital data printing)	(Scale printing)	(List printing)

1 In case no engineering unit is programmed;

An engineering unit is decided by the range number programmed in the [Range/Printing range] programming.

Voltage range		Temperature range	
mV (01 to 05)	V (06 to 10)	°C (Nos. other than ones shown on the right)	K (47, 80)

2 Programming Mode

Engineering unit character (Fixed) Cursor Channel

Digit No. of engineering unit character *2 (Up to 5 digits.)

(Numeric numbers (1 to 5) appear for the digit not programmed by pressing .)

*1: Engineering unit character

The character at the digit where the digit number is pointed by the cursor is displayed.

*2: Digit No. of engineering unit character

A digit No. 1 to 5 is displayed by pressing .

<To decrease the digit No.>

Press **SHIFT** and **CLEAR** simultaneously to clear the digit No. and press for reprogramming a new digit No.

If the range No. is changed;

A programmed engineering unit is deleted and the engineering unit determined by the range No. is displayed

If clear is stored at scale programming;

If the scale is cleared in a channel; the engineering unit of this channel is deleted, and it becomes the engineering unit determined by range No.

3 Programming Flow Chart

<Example> From PPM to G/MIN in CH 3

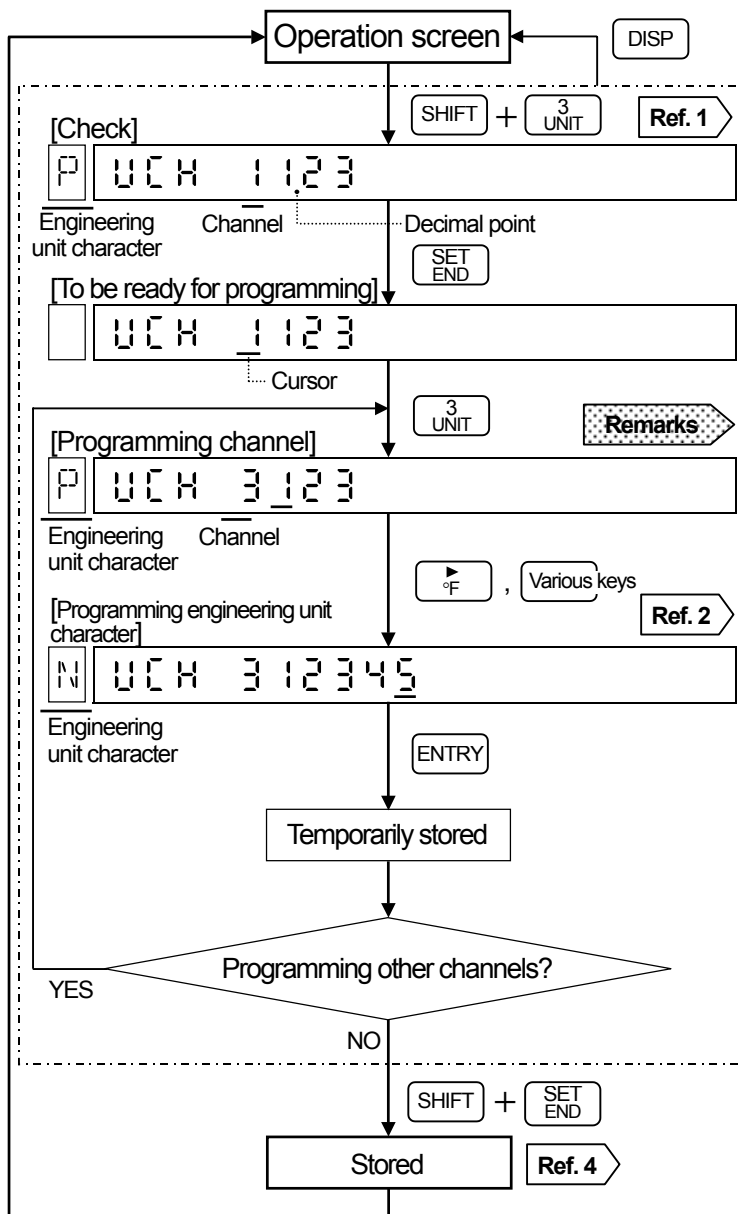

Remarks To program engineering unit to "none"

- (1) Select the channel to be "none" with \uparrow or $\%$.*
 - (2) Press **SHIFT** and 0 CLEAR simultaneously to clear and perform [temporarily stored] and then [stored].
- * If the channel is programmed by a numeric value and cleared, the engineering unit of channel before programming change is programmed to be "none".

Reference 1 To check all programmed digits

- Press \uparrow or $\%$ to change channels.
- The digit displaying an engineering unit character (digit No. with decimal point) shifts with °F or °C .

Reference 2 Programmable characters and key operation

- Numeric value (0 to 9): 0 CLEAR to 9 LIST , and r' (-)
- Alphabetic characters (A to Z): Press **SHIFT** and A-Z simultaneously and select a character by pressing \uparrow or $\%$.
- Special characters (% , / , °C , °F)
 - $\%$ (**SHIFT** + $\%$)
 - $/$ (**SHIFT** + \uparrow)
 - °C (**SHIFT** + °C)*
 - °F (**SHIFT** + °F)*

*A space corresponding to 2 digits is used.

- SPACE COPY(=) (space): A space is treated as a character.

Reference 3 °C, °F engineering unit

These engineering units are treated as a printing unit only. They are not treated as computing units.

Reference 4 Storing

Store the [temporarily stored] parameters into the memory. (A programming change mark is printed.)

Tags up to 9 digits can be assigned for digital data printing and scale printing.

Press **SHIFT** and **TAG** simultaneously to display the [Tag] programming screen. The default is no programming of tags.

Example of tag printing (AL3000)

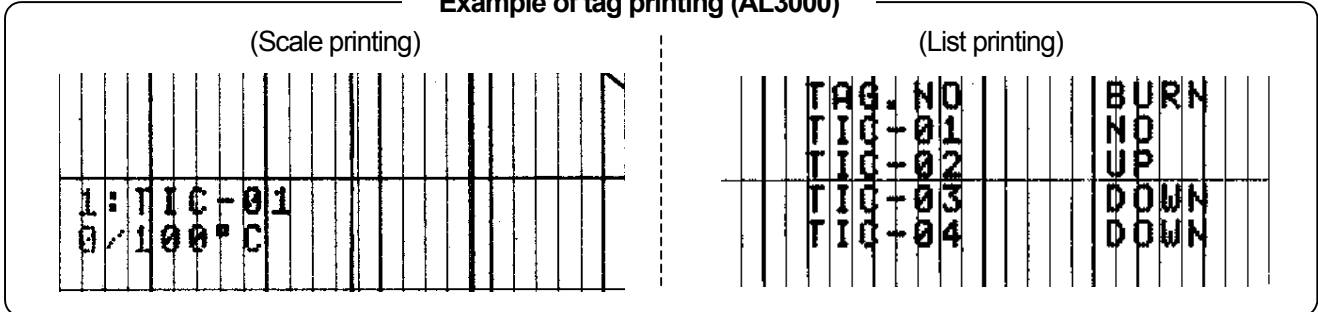

1 Programming Mode

Note) The default is no programming of tags. The following figure is an example of 9-digit tag programmed.

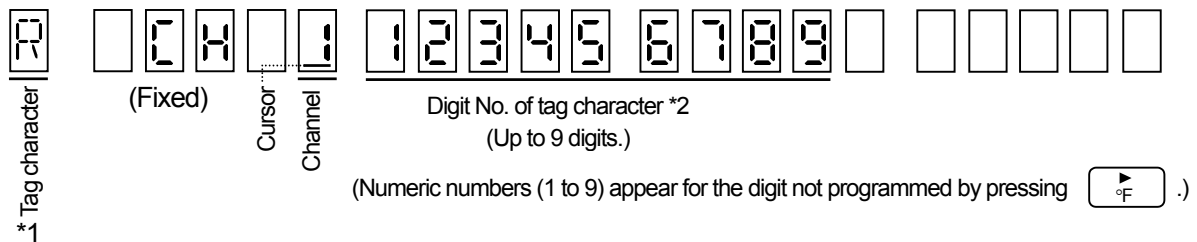

*1: Tag character

The character at the digit where the digit number is pointed by the cursor is displayed.

*2: Digit No. of tag character

A digit No. 1 to 9 is displayed by pressing **F**.

<To decrease the digit No.>

Press **SHIFT** and **CLEAR** simultaneously to clear the digit No. and press **F** for reprogramming a new digit No.

If clear is stored in the scale mode;

If the scale is cleared in a channel; the tag of this channel is deleted. Reprogram it if necessary.

2 Programming Flow Chart

<Example> From TIC to 10 in CH 3

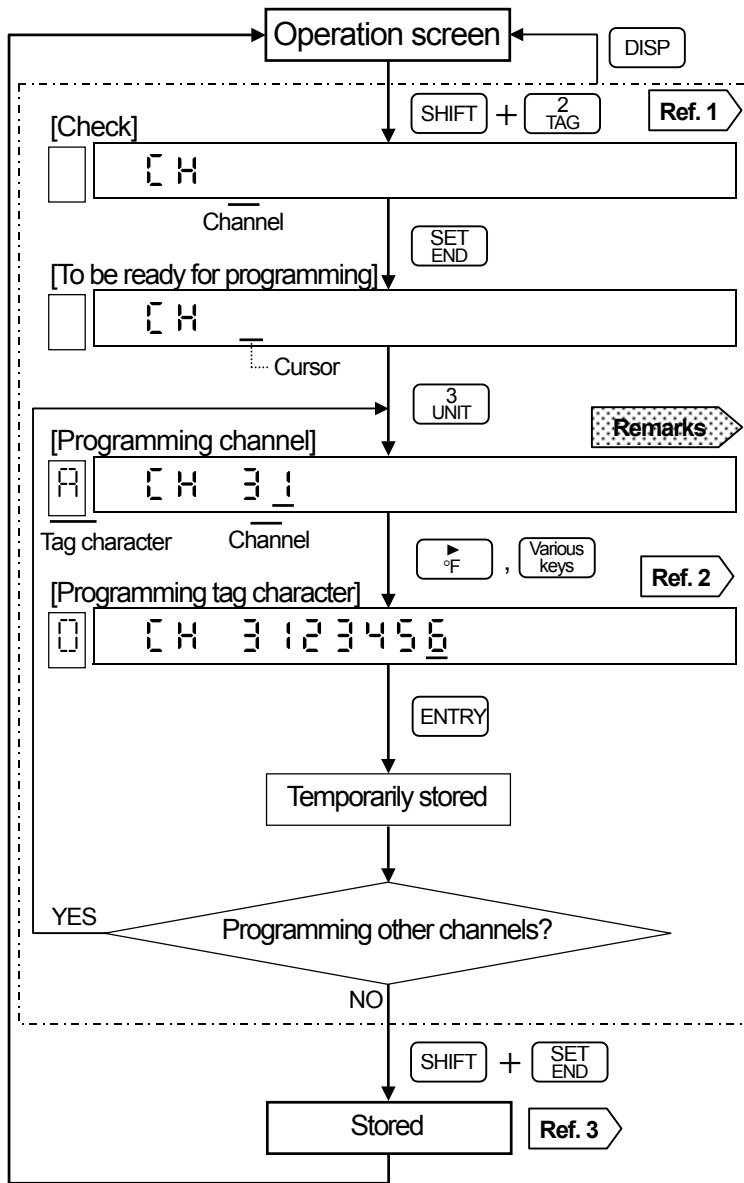

Remarks To program tag to "none"

- (1) Select the channel to be "none" with \uparrow or $\%$.*
 - (2) Press **SHIFT** and CLEAR^0 simultaneously to clear and perform [temporarily stored] and then [stored].
- * If the channel is programmed by a numeric value and cleared, the engineering unit of channel before programming change is programmed to be "none".

Reference 1 To check all programmed digits

- Tag characters are displayed only for the programmed channels (Digit Nos. appear.).
- Press \uparrow or $\%$ to change channels.
 - The digit displaying a tag character (digit No. with decimal point) shifts with °F or °C .

Reference 2 Programmable characters and key operation

- Numeric value (0 to 9): CLEAR^0 to LIST^9 , and $\text{r}^{\text{(-)}}$
- Alphabetical characters (A to Z): Press **SHIFT** and A-Z^6 simultaneously and select a character by pressing \uparrow or $\%$.
- Special characters ($\%$, $/$, °C , °F)
 - $\%$ (**SHIFT** + $\%$)
 - $/$ (**SHIFT** + \uparrow)
 - °C (**SHIFT** + °C)*
 - °F (**SHIFT** + °F)*

*A space corresponding to 2 digits is used.

- $\text{SPACE COPY}^{\text{(=)}}$ (space): A space is treated as a character.

Reference 3 Storing

Store the [temporarily stored] parameters into the memory. (A programming change mark is printed.)

11. OTHER PROGRAMMING

11.10 Message

Messages are printed from (1) key operation or (2) remote contacts signal*. A message up to 15 digits and 5 different messages (No.1 to No. 5) can be programmed. Press and simultaneously for 3 seconds or more to display the [Message] programming screen.

* This function is only available in the remote contacts (option). See Section 13.1.

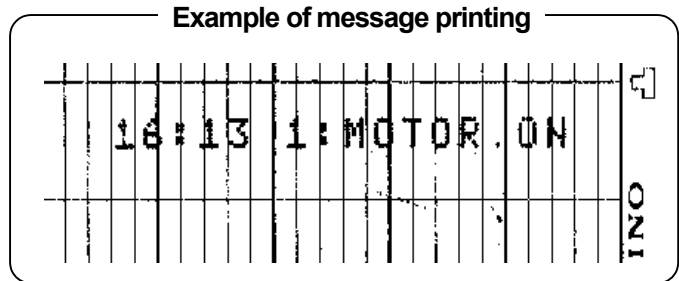

1 Programming Mode

Note) The default is no programming of messages. The following figure is an example of 8-digit message programmed for No.1.

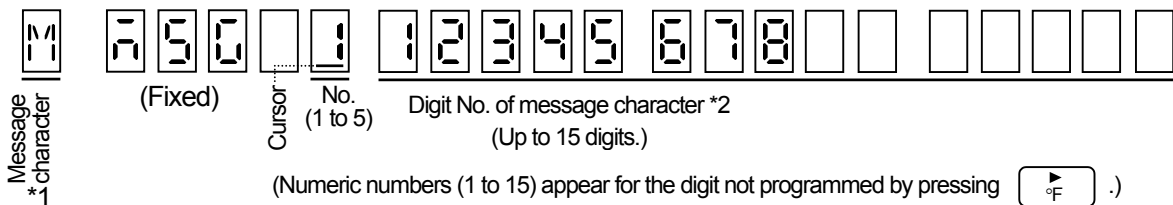

*1: Message character

The character at the digit where the digit number is pointed by the cursor is displayed.

*2: Digit No. of message character

A digit No. 1 to 15 is displayed by pressing .

<To decrease the digit No.>

Press and simultaneously to clear the digit No. and press for reprogramming a new digit No.

2 Programming Flow Chart

<Example> From "none" to "MOTOR ON".

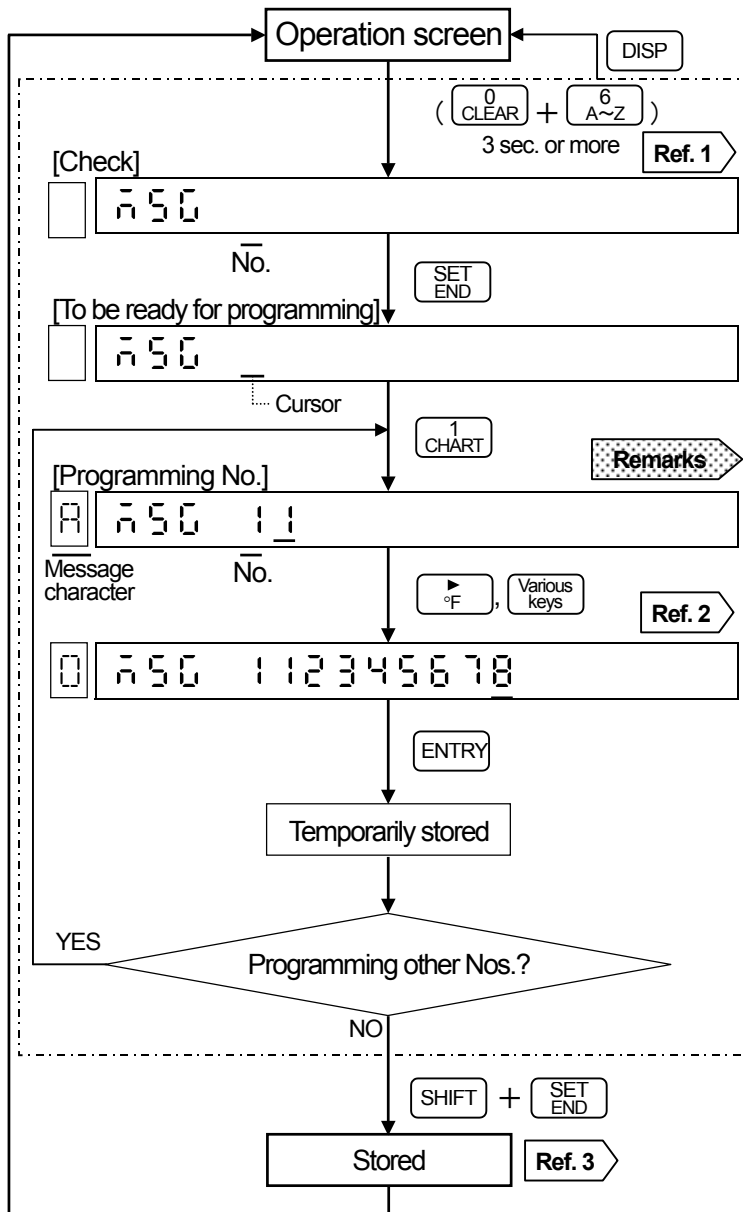

Remarks To program message to "none"

- Select the channel to be "none" with **↑** or **↓** or **%**.*
 - Press **SHIFT** and **0 CLEAR** simultaneously to clear and perform [temporarily stored] and then [stored].
- * If the channel is programmed by a numeric value and cleared, the engineering unit of channel before programming change is programmed to be "none".

Reference 1 To check all programmed digits

- Message characters are displayed only for the programmed channels. (Digit Nos. appear.)
- Press **↑** or **↓** to change channels.
 - The digit displaying a tag character (digit No. with decimal point) shifts with **°F** or **°C**.

Reference 2 Programmable characters and key operation

- Numeric value (0 to 9): **0 CLEAR** to **9 LIST**, and **° (-)**
 - Alphabetical characters (A to Z): Press **SHIFT** and **6 A~Z** simultaneously and select a character by pressing **↑** or **↓**.
 - Special characters (% , / °C °F)
 - %** (**SHIFT** + **↓ %**)
 - /** (**SHIFT** + **↑ /**)
 - °C** (**SHIFT** + **°C**)*
 - °F** (**SHIFT** + **°F**)*
- *A space corresponding to 2 digits is used.
- SPACE COPY (=)** (space): A space is treated as a character.

Reference 3 Storing

Store the [temporarily stored] parameters into the memory. (A programming change mark is printed.)

The channel where the temperature range is programmed becomes effective. Press **[SHIFT]** and **[▼ %]** simultaneously in the operation screen for 3 seconds or more to display the [Burnout] programming screen. This programming is necessary for each channel.

1 Burnout

- If a sensor (thermocouple or resistance thermometer) is disconnected, trace printing overshoots maximum or minimum limit.
- The default parameter of burnout is “disable” (non) in all channels.

Burnout selection menu

Burnout can be selected for each channel out of 3 types shown below.

non (Non)	: Burnout disable
UP burn (UP burn)	: Up scale burnout
down burn (down burn)	: Down scale burnout

2 Programmed Flow Chart

<Example> From burnout “disable” to “up scale burnout”

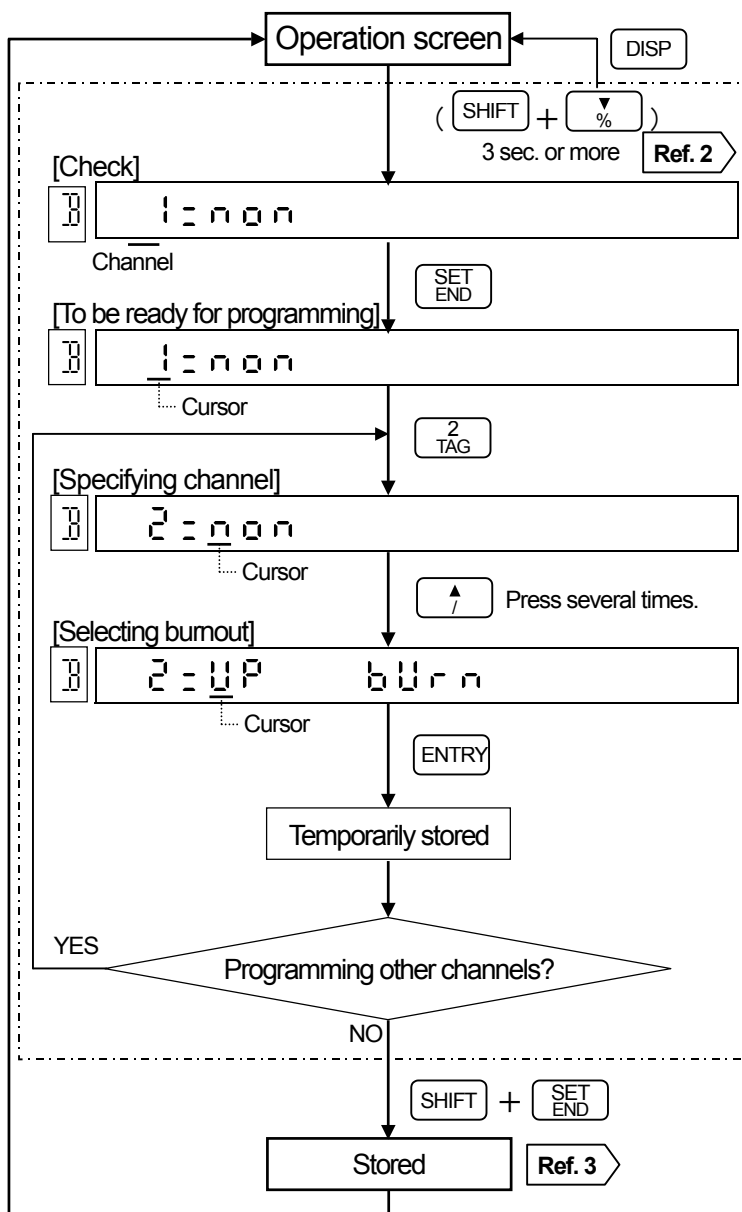

Remarks 1 “non” programming on parallel operation

A parallel connection of a thermocouple with other instrument causes a problem. Select (non) if your recorder uses the thermocouple being connected with other instrument.

Remarks 2 Voltage range is ineffective

Even if the burnout is programmed to a channel where the voltage range (No. 01 to 07) is programmed, this programming becomes ineffective (burnout disable).

Reference 1 Burnout operation

For the burnout operation (display and printing), read Section 10.2.

Reference 2 Other channels check

Press **[↑]** or **[▼ %]** to change channels. The programmed burnout of other channels can be checked.

Reference 3 Storing

Store the [temporarily stored] parameters into memory. (Programming change mark is printed.)

11. OTHER PROGRAMMING

11.12 Passcode/Key Lock

The procedure for [Key lock] programming differs depending on whether a passcode is programmed or not.

Press [SHIFT] and [↑] simultaneously in the operation screen for 3 seconds or more to display the [Passcode programmed/not programmed] check screen. If a passcode has been already programmed, it is not allowed to go to the [Key lock] programming screen unless entering the correct passcode.

1 Passcode

- [Key lock] programming cannot be allowed unless entering the correct passcode.
- As the default is no passcode programmed, you can program [Key lock].

Passcode programming range

Program a passcode with a 4-digit numeric value.
Programming range: 0001 to 9999
If "0000" is programmed, a programming error occurs.

Remarks Keep your passcode in mind

Keep the passcode programmed in mind or somewhere safe. If you lose the passcode, no [Key lock] operation will be available.

2 Key Lock

When [Key lock] is programmed to "LOCKED", no key operation for the following functions is accepted.

- (1) Reprogramming of various parameters
- (2) Operations (printing ON/OFF, chart paper feeding, digital data printing, printing format selection, and time axis synchronization selection)

The following operations are exceptional.

- (1) Checking various parameters
- (2) Programming the key lock to be ineffective (UNLOCKED)
- (3) Selection of operation screens

Reference In key lock

The status [KEY LOCK] (blue) lights when the key lock is effective.

3 Programming Flow Chart

The flow differs depending on whether a passcode is programmed or not. See next page for details.

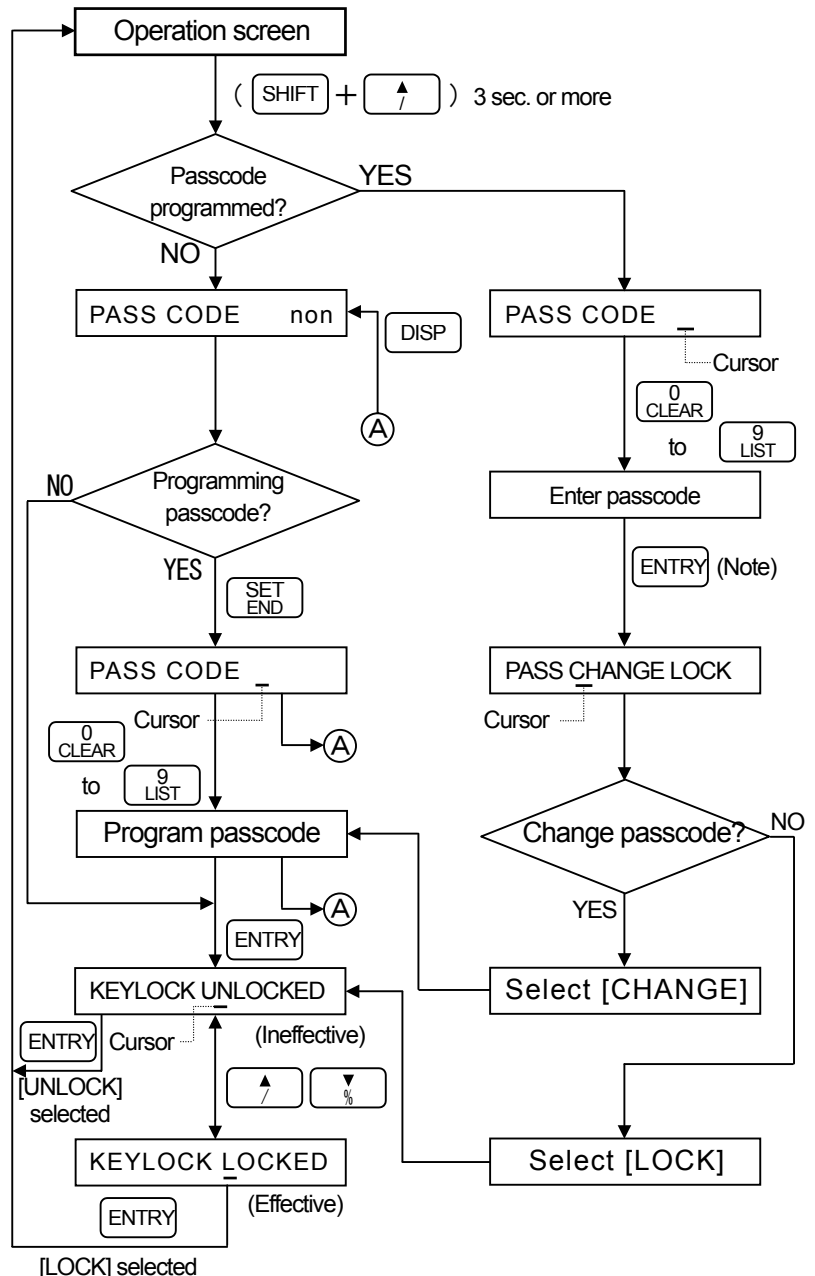

(Note) In case an error message appears, press any key other than [SHIFT] and reprogram.

4 When a passcode has not been programmed

<Example> Program the passcode and [key lock] effective

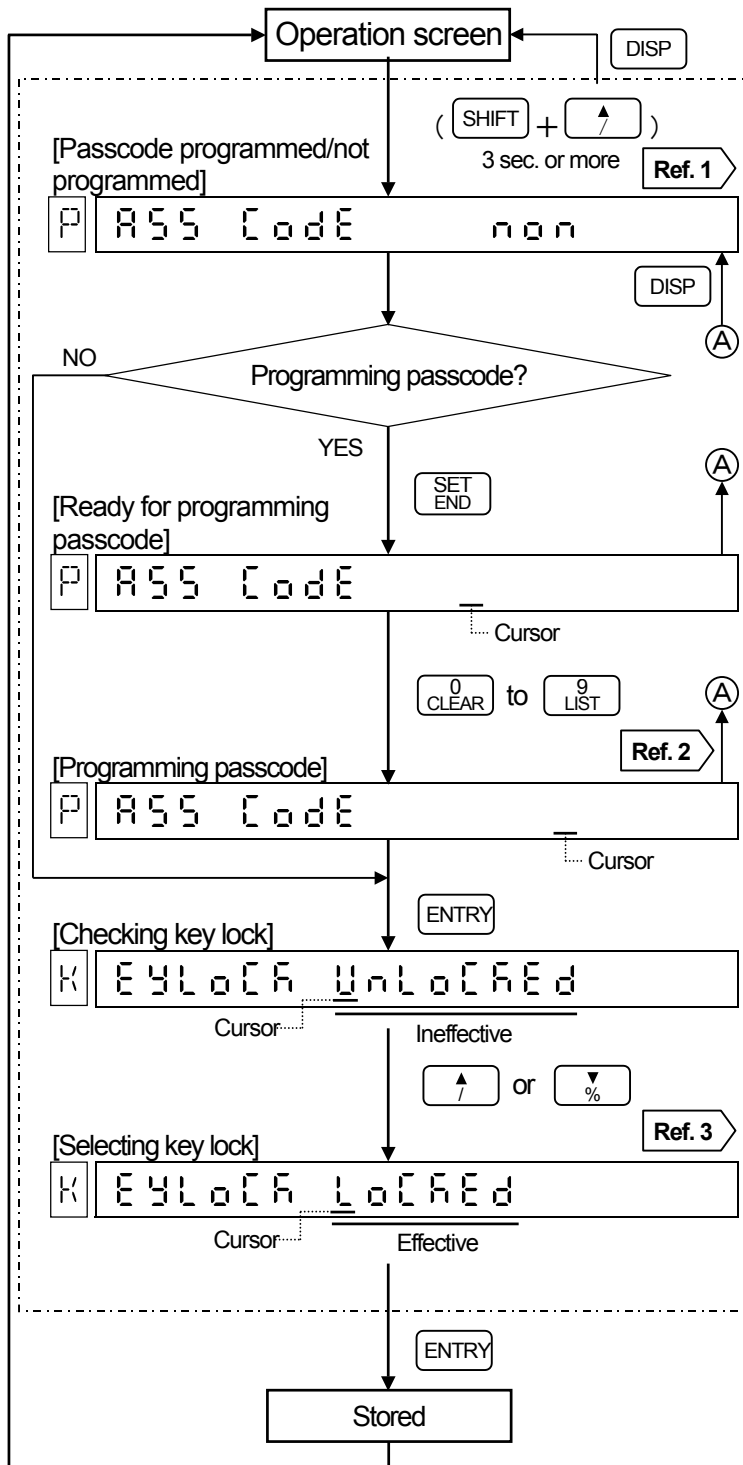

Reference 1 Passcode programmed/not programmed

nnn: Passcode has not been programmed.

—: Passcode has been programmed. See Section 5 on the next page.

Reference 2 When a passcode programmed

- (1) The numeric figures for the passcode will not appear.
- (2) If a passcode has been programmed, the [Key lock] selection is not available without entering the correct passcode. The flow chart shown in 5 is for the procedure of [Key lock] selection when a passcode has been programmed.

Reference 3 Selection of key lock ineffective or effective

Press ↑ or ↓ to select the key lock to be effective or ineffective.

5 When a passcode has been programmed

<Example> Key lock to be effective when the passcode is changed or unchanged

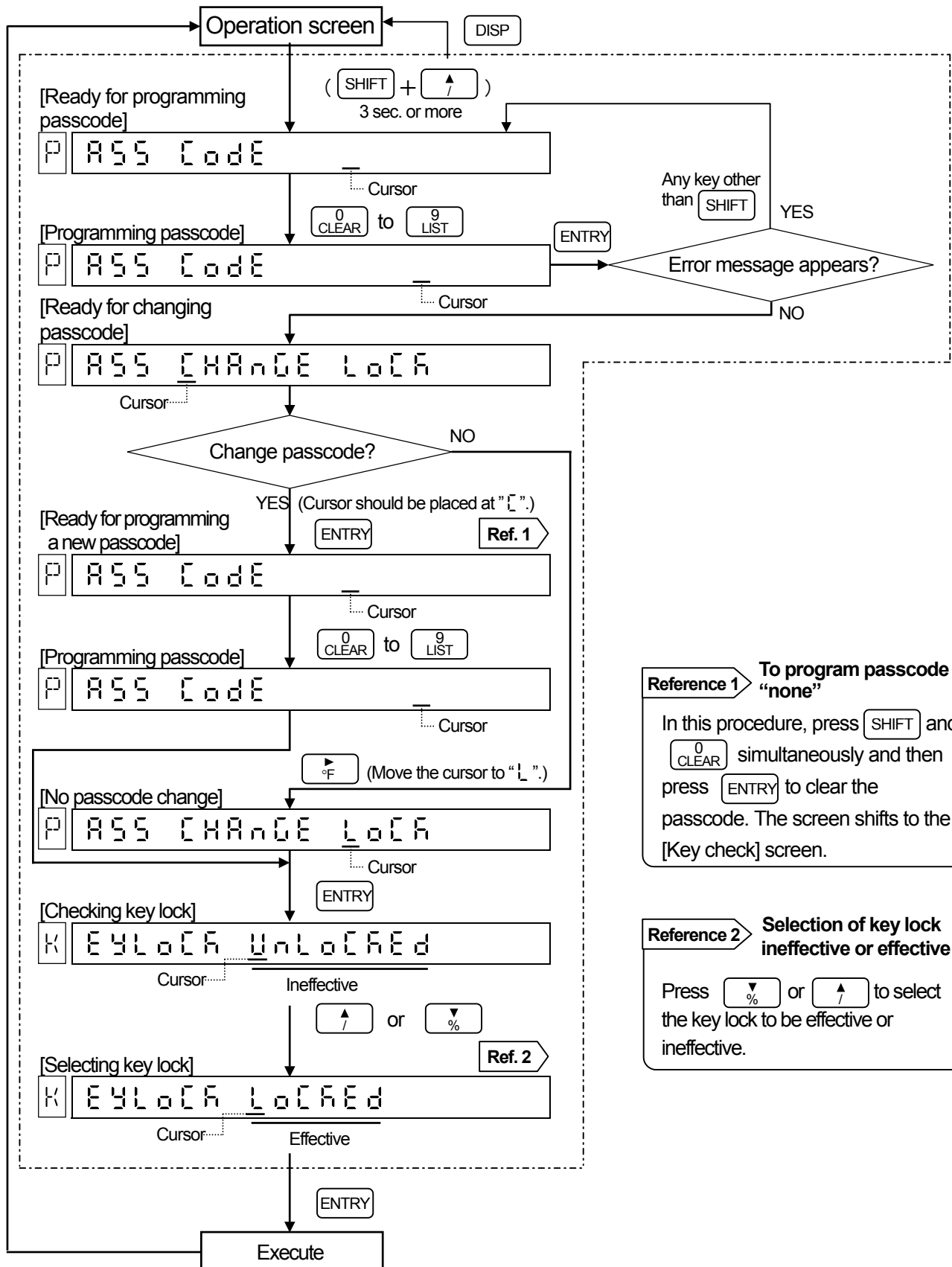

Reference 1 To program passcode to "none"

In this procedure, press (SHIFT) and (0 CLEAR) simultaneously and then press (ENTRY) to clear the passcode. The screen shifts to the [Key check] screen.

Reference 2 Selection of key lock ineffective or effective

Press (DOWN) or (UP) to select the key lock to be effective or ineffective.

The input filter has a function to stabilize the measuring input. This function can be programmed for each channel. Press **0** **CLEAR** and **8** **ALARM** simultaneously for 3 seconds or more to display the [Input filter] programming screen.

1 Input Filter

A CR filter is mounted in the measuring circuit. In addition, a software filter (called as "input filter") for the "primary delay computation" is also installed to smooth slight variations of the measuring input. The value for the programming is corresponding to "Time constant: T".

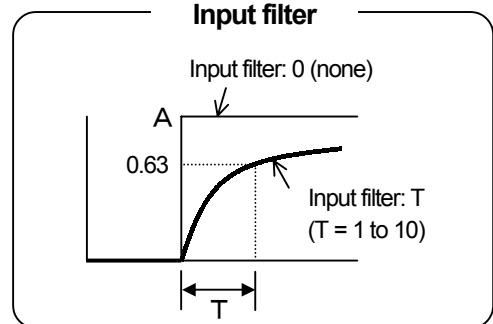

2 Programming Flow Chart

<Example> To the time constant 5 seconds in CH2

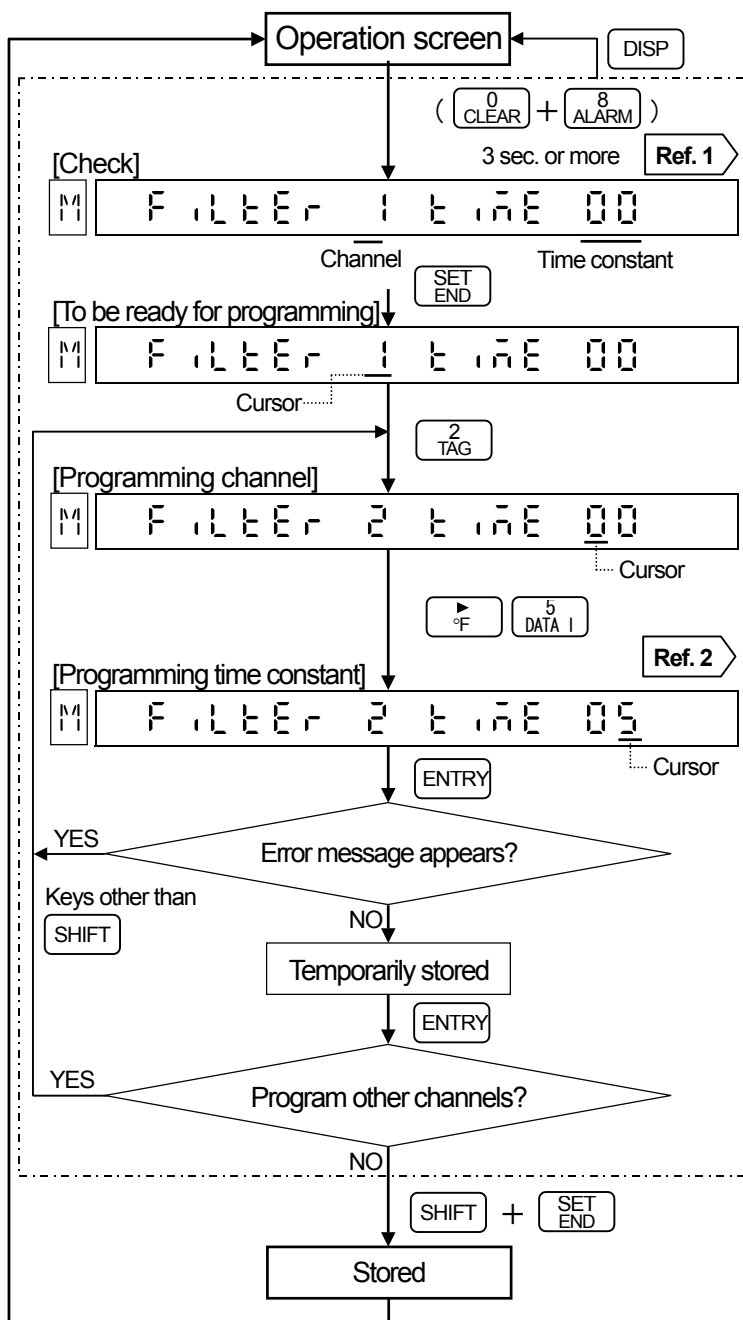

Reference 1 Other channels check

Press **▼** **%** or **▲** **/** to change channels. The input filter time constant of other channels can be checked.

Reference 2 Programming range of time constant

0, 1 to 10
If "0" is programmed, the input filter is disabled.

Reference 3 Storing

Store the [temporarily stored] parameters into memory. (A programming change mark is printed.)

11. OTHER PROGRAMMING

11.14 Copying to Other channels

For the parameters, such as [range/printing range], [scale], [engineering unit] and [tag], which are needed to be programmed in each channel, the parameters of the specific channel as a reference channel can be copied to a desired channel.

1 Programming Mode ...Example of [range/printing range]

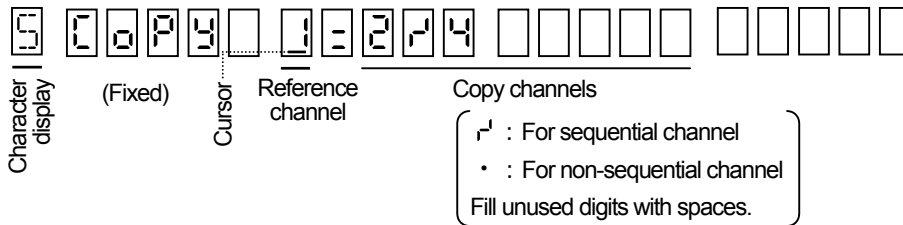

Character display

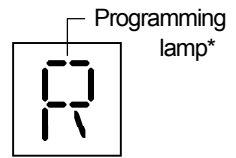

* R: Range/Printing range
S: Scale
U: Engineering unit
T: Tag

2 Programming Flow Chart

<Example> Copying of parameters for [range/printing range] in CH 1 to CH 2 to 4.

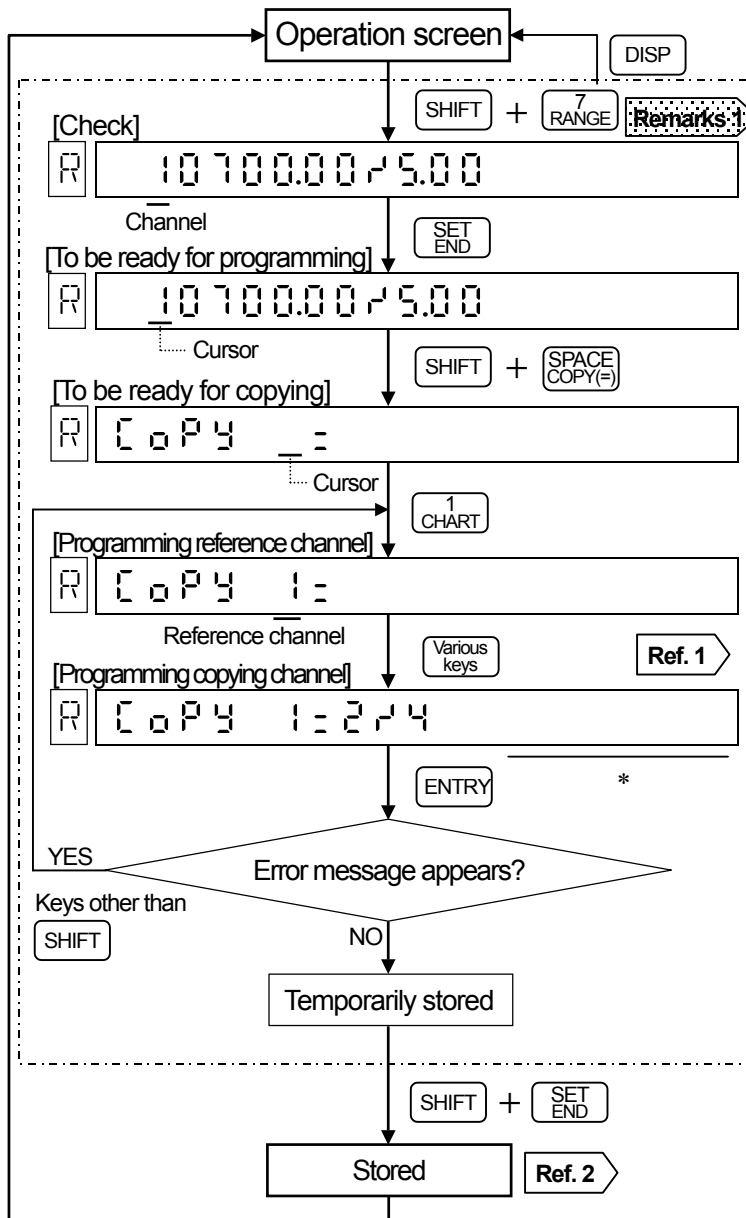

Remarks 1 Check if any skip channel is programmed

Press \uparrow or $\%$ to check if any skip channel is programmed.

Reference 1 Various keys

- Programming "to": SHIFT + $r(-)$
- Decimal point: $\dot{\text{CLOCK}}$ in the next digit
- Deletion of decimal point: SPACE COPY(=) in the next digit

Reference 2 Storing

Store the [temporarily stored] parameters into memory. (A programming change mark is printed.)

* Fill unused digits with spaces.

12. ALARM OUTPUT | 12.1 Alarm Output Programming Items

This explanation is only for the alarm output (option). The alarm output programming is necessary after programming the “alarm”.

1 Programming Items for Alarm Output

1) Relay No.	Setting of the relay No. where the alarm information (activation/reset) of each alarm point is to be output. Set them to each alarm point.
2) Output wiring	Setting to AND or OR for each relay No.. When one relay is used by multiple alarm points, you can select AND or OR for the output wiring.
3) Output mode	(1) Relay coil phase: Setting whether N and O terminals are shorted (Energized) or opened (Non-energized) when an alarm activates.
	(2) Relay output latch: Setting whether the alarm status is to be continued until <input type="checkbox"/> ENTRY is pressed (Hold) even if the alarm becomes reset condition, or it is reset (Not hold) at the same time as resetting of the alarm.
	(3) Alarm display* latch: Setting whether the alarm display is kept displayed until <input type="checkbox"/> ENTRY is pressed (Hold) even if the alarm becomes reset condition or turned off (Not hold) at the same time as resetting of the alarm. * Alarm display: <input type="checkbox"/> ALARM status lamp

2 Details of Programming Items

1) Relay No. and default values

Alarm *		
Alarm point	Alarm type	Relay No.
CH 1	Level 1	0
	Level 2	0
	Level 3	0
	Level 4	0
CH 2 (2 to 4-pen types only)	Level 1	0
	Level 2	0
	Level 3	0
	Level 4	0
CH 3 (3 and 4-pen types only)	Level 1	0
	Level 2	0
	Level 3	0
	Level 4	0
CH 4 (4-pen type only)	Level 1	0
	Level 2	0
	Level 3	0
	Level 4	0
FAiL		0
C. End		0

2) AND/OR, output mode and default values

Relay No.	AND/OR	Output Mode		
		Relay coil phase	Relay output latch	Alarm display latch
RLy1	or	Energized (Common to all relays)	Not hold (Common to all relays)	Not hold (Common to all displays)
RLy2	or			
RLy3	or			
RLy4	or			
RLy5	or			
RLy6	or			
RLy7	or			
RLy8	or			
RLy9	or			
RLy10	or			
RLy11	or			
RLy12	or			

* AL3000: Relay No. is 1 to 6.

AH3000: it is variable depending on the number of output points (Rel;ay No. is 1 to 12 for 12-point outputs.).

*This is the “Alarm” programming. The relay No. is fixed at 0 in the standard specifications (AH is fixed at 00). 1 to n (Note) should be set only when alarm output (option) is added. (0 means no output.)

(Note) n: 6 or 12 depending on the number of output points.

AL3000: 6 only

12. ALARM OUTPUT | 12.2 Programming of Relay No.

This explanation is only for the alarm output (option). Program the relay No. for each alarm point by referring the "Programming relay No." screen in "Section 11.5 Alarm, 4 Programming flow chart, 2) With alarm output (option)".

1 Alarm Output Terminals and the Status

When an alarm is in active at an alarm point, the relay No. (alarm output terminal No.) specified for the point is activated.*

*The terminal activation differs depending on the programming of the relay coil to "Energize" or "Non energize". => See Section 12.4.

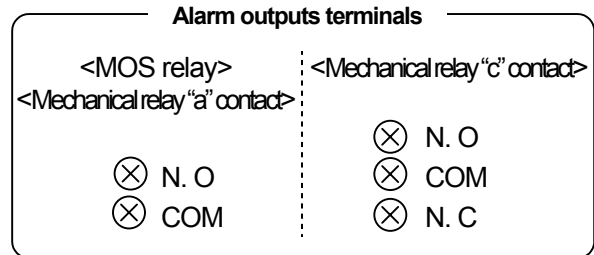

2 Programming Relay No.

For programming [Relay No.], refer to the programming flow chart in "Section 11.5 Alarm, 4 Programming flow chart, 2) With alarm output (option)". The default is "0" and no alarm output is available. Select an alarm type and press . The cursor moves to the relay No. to specify relay Nos. for each alarm point.

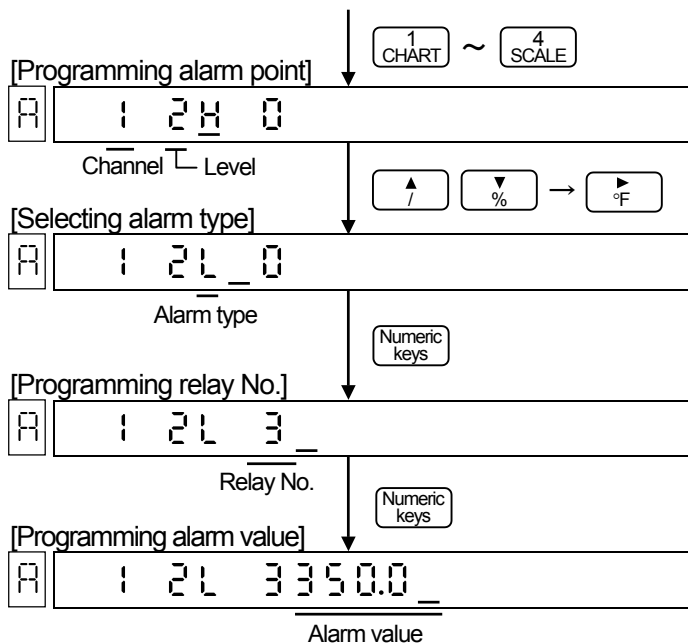

Number of relay No. digits
Each relay No. is composed of two digits. For relay Nos. 0 to 9, set or .

Select an alarm type and press to move the cursor to the relay No. screen. No output is available when the relay No. is programmed to "0". The relay No. for AH is displayed as "00".

Program a relay No. from "0" to "n". The example is for programming to "3". Program "0" if no output is necessary.

The programming after this step or before the alarm type selection, refer to the flow chart in Section 11.5. 4 2).

Remarks 1 **Number of alarm point and number of output point (n)**
The total numbers of alarm points are number of channels x number of levels (4) + 2 (FAiL and C. End). Number of output points is 6 or 12 points. (AL3000: 6 points only)

Remarks 2 **FAiL, C. End**
Place the cursor to the column of channel in "Selecting alarm type" and press until "Fail" or "C. End" is displayed. In this condition, select a relay No. to output when the corresponding phenomenon occurs.

12. ALARM OUTPUT | 12.3 Output Wiring (AND/OR) Setting

This explanation is only for the alarm output (option). Press CLEAR and °C simultaneously for 3 seconds or more to display the "Output Wiring (AND or OR)" programming screen. Program it for each relay No. The default is "OR" for all relay Nos.

1 AND/OR

Multiple alarm points can be allocated to one relay No.

- AND output: The relay turns on when all alarm points allocated are in active.
- OR output: The relay turns on when any of the alarm points allocated is in active.

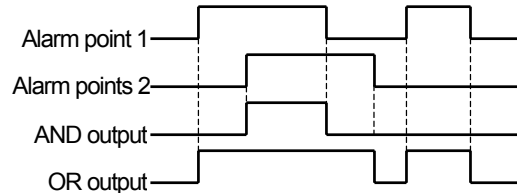

2 Selecting Flow Chart

<Example> From OR to AND in relay No. 3

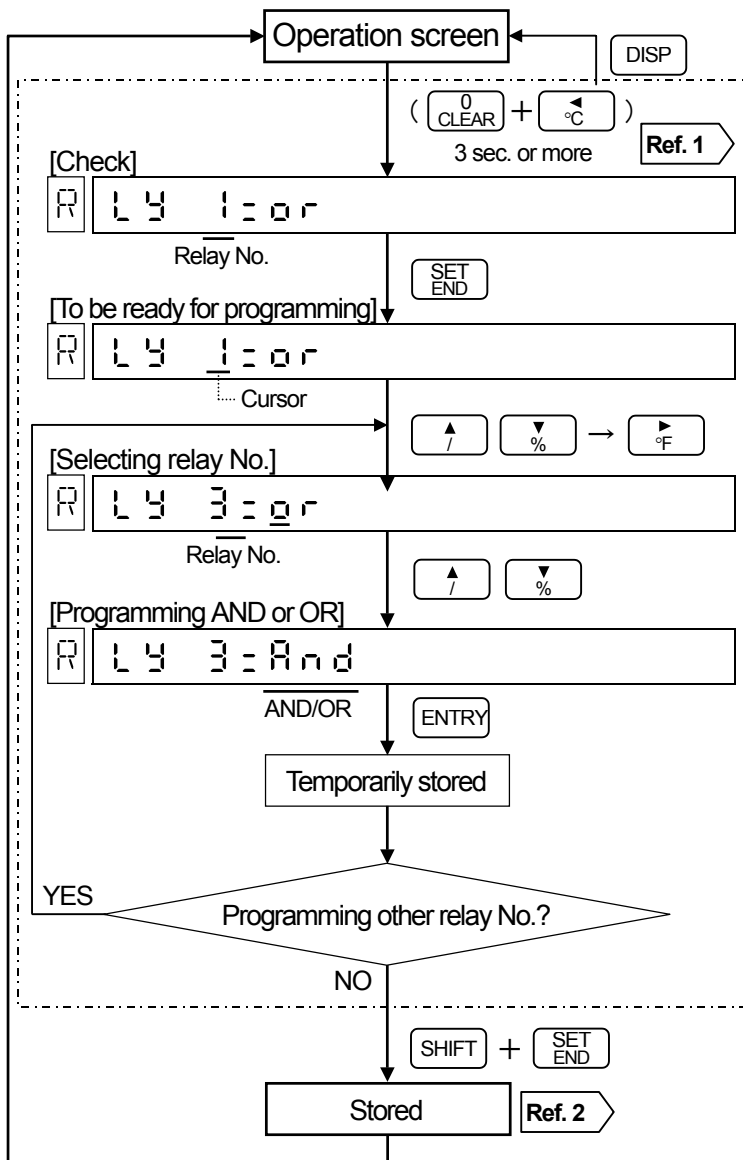

Reference 1 Checking other relay No.

Press \uparrow or \downarrow to change relay No. AND/OR status of other channels can be checked.

Reference 2 Storing

Store the [temporarily stored] parameters into memory. (Programming change mark is printed.)

12. ALARM OUTPUT | 12.4 Programming Output Mode

This explanation is only for the alarm output (option). Press **DISP** and **↶** simultaneously for 3 seconds or more to display the “Output mode” programming screen. Two output modes, 1) relay coil (energize/not energize), 2) latched alarm display/relay (hold/not hold), are available. The programming is common to all relay Nos..

1 Relay Coil Energize/Not energize

The default is “Energize”.

The terminal configuration differs depending on the type of relay.

1) MOS relay and mechanical relay “a” contact alarm output

Phase	Power off	Alarm reset	Alarm activation
Energized (E)			
Not energize (d)			

2) Mechanical relay “c” contact alarm output

Phase	Power off	Alarm reset	Alarm activation
Energize (E)			
Not energize (d)			

12. ALARM OUTPUT | 12.4 Programming Output Mode

2 Latched Alarm Display/Relay (Hold/Not hold)

The default is "Not hold".

The alarm display refers to the blinking of the measured value and the lighting of **ALARM** status lamp.

1) Not hold (N)

The output is not affected by **ENTRY**.

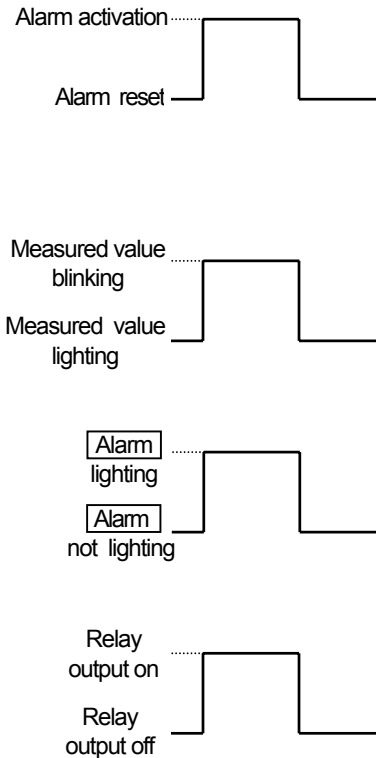

2) Hold (H)

The output is held until **ENTRY** is pressed. The output differs depending on the timing of pressing **ENTRY**.

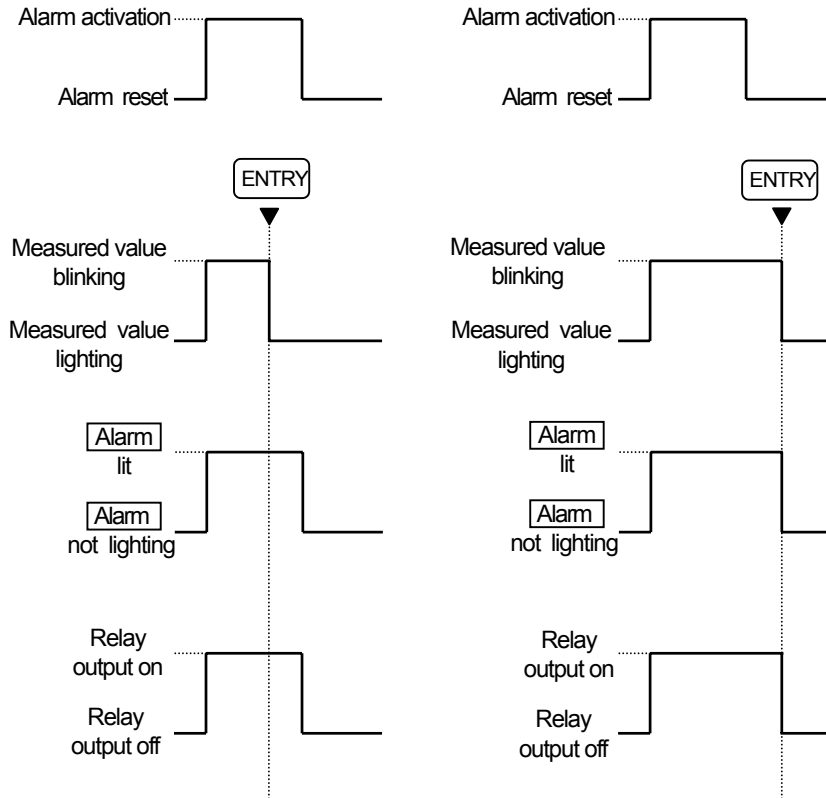

Reference

Blinking of measured value

The measured value blinks when an alarm activates and lights steadily when it is reset.

However, the blinking is continued when the alarm display/relay is hold.

The blinking is turned to steadily light by pressing **ENTRY** regardless of the programming of "Hold" or "Not hold".

12. ALARM OUTPUT | 12.4 Programming Output Mode

4 Programming Mode

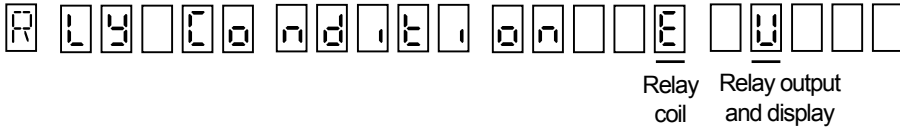

5 Programming Flow Chart

<Example> Programming the relay coil phase to Energize, relay output/display to Hold and alarm display to Hold:

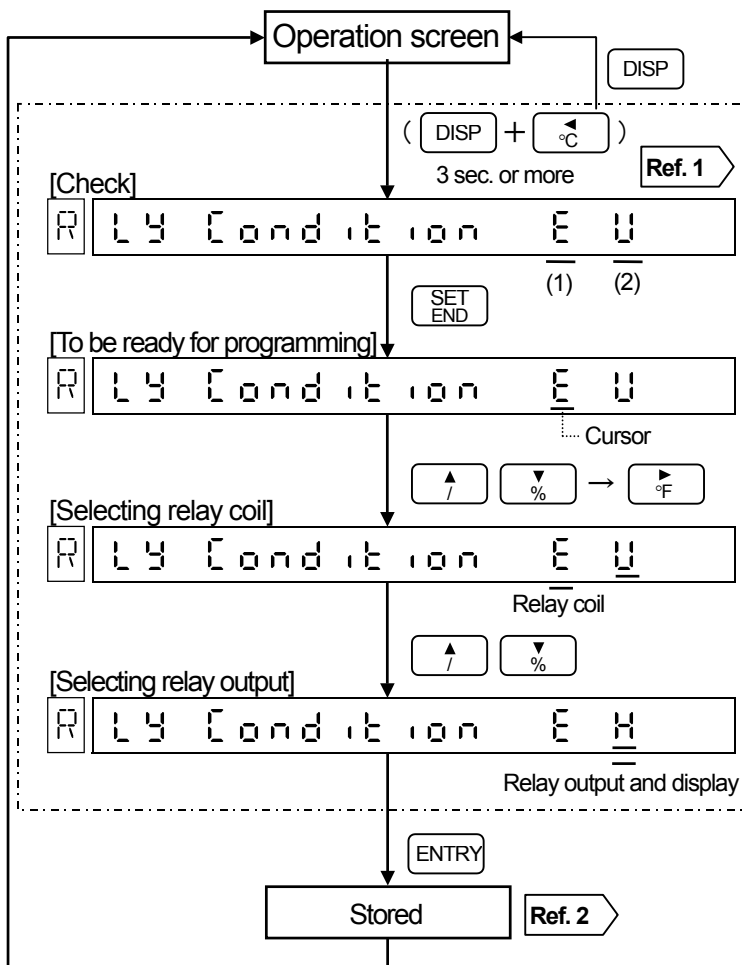

Reference 1 Checking

The parameters are displayed in order of (1) relay coil phase, (2) relay output and (3) alarm display.

Relay coil phase	E: Energize	Not energize
Relay output/display	H: Hold	U: Not hold

Reference 2 Stored

Store the parameters into memory. (Programming change mark is printed.)

13. REMOTE CONTACTS

13.1 Remote Contacts Function

This explanation is only for the remote contacts (option).

1 Remote Contacts

- (1) The following functions are available with the contact signals at remote contacts terminals (EX1 to 4). However, the functions are limited due to four terminals (EX1 to 4) provided. Moreover, some functions are automatically allocated to a certain terminal Nos.
- (2) Programming to allocate the functions to terminal Nos. is necessary.

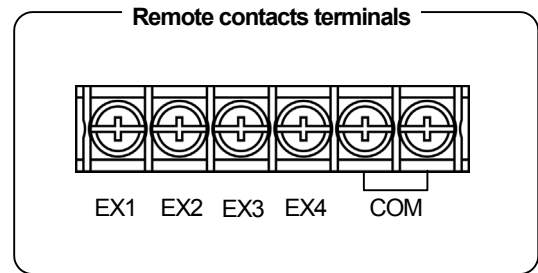

Functions	Terminals	Remarks
(1) Printing on/off and selection of three chart speeds	2 terminals (EX1, EX2)	Programming 3 speeds, See Section 13.3. (Note 1)
(2) Execution of message printing (No.1 to 5)	4 terminals (EX1 to EX4)	Programming message, See Section 11.10. (Note 2)
(3) Execution of message printing (No.1 and 2)	2 terminals (EX1, EX2)	Programming message, See Section 11.10. (Note 3)
(4) Execution of digital data printing	Any 1 terminal	
(5) Execution of list printing (list 1, 2, 3)	Any 3 terminals	
(6) Execution of operation record (No.A to D)	Any 4 terminals	Programming operation record, See Section 13.4.
(7) Reset of totalization	Any 1 terminal	Available in totalization (option)

(Note 1) Free terminals left are EX3 and EX4.

(Note 2) No free terminals are left.

(Note 3) Free terminals left are EX3 and EX4.

2 Functions and Terminal Contact Signals



ON: Short OFF: Open

Functions	Contact signal at terminal																														
(1) Printing on/off and selection of 3 chart speeds	<ul style="list-style-type: none"> • Program 3 chart speeds first. See Section 13.3. <table border="1"> <thead> <tr> <th rowspan="2">Printing on/off and selection of 3 chart speeds</th> <th colspan="2">With COM</th> </tr> <tr> <th>EX1</th> <th>EX2</th> </tr> </thead> <tbody> <tr> <td rowspan="3">Printing: On</td> <td>CS1</td> <td>OFF</td> <td>OFF</td> </tr> <tr> <td>CS2</td> <td>ON</td> <td>OFF</td> </tr> <tr> <td>CS3</td> <td>OFF</td> <td>ON</td> </tr> <tr> <td>Printing: Off</td> <td>ON</td> <td>ON</td> </tr> </tbody> </table>	Printing on/off and selection of 3 chart speeds	With COM		EX1	EX2	Printing: On	CS1	OFF	OFF	CS2	ON	OFF	CS3	OFF	ON	Printing: Off	ON	ON												
	Printing on/off and selection of 3 chart speeds		With COM																												
EX1		EX2																													
Printing: On	CS1	OFF	OFF																												
	CS2	ON	OFF																												
	CS3	OFF	ON																												
Printing: Off	ON	ON																													
(2) Execution of message printing (No. 1 to 5)	<ul style="list-style-type: none"> • Program messages first. See Section 11.10. <table border="1"> <thead> <tr> <th rowspan="2">Message</th> <th colspan="4">With COM</th> </tr> <tr> <th>EX1</th> <th>EX2</th> <th>EX3</th> <th>EX4*</th> </tr> </thead> <tbody> <tr> <td>No.1</td> <td>OFF</td> <td>OFF</td> <td>OFF</td> <td rowspan="5"> For triaccer </td> </tr> <tr> <td>No.2</td> <td>ON</td> <td>OFF</td> <td>OFF</td> </tr> <tr> <td>No.3</td> <td>OFF</td> <td>ON</td> <td>OFF</td> </tr> <tr> <td>No.4</td> <td>ON</td> <td>ON</td> <td>OFF</td> </tr> <tr> <td>No.5</td> <td>OFF</td> <td>OFF</td> <td>ON</td> </tr> </tbody> </table> <p>* When the trigger signals is sent (for 1 sec. or more) after selecting the message No., the printing of programmed message starts.</p> <p>(Note) Program "Printing on/off" to on with a key operation in advance. Execution of message printing with key operation is also available. See Section 9.4.</p>	Message	With COM				EX1	EX2	EX3	EX4*	No.1	OFF	OFF	OFF	For triaccer 	No.2	ON	OFF	OFF	No.3	OFF	ON	OFF	No.4	ON	ON	OFF	No.5	OFF	OFF	ON
Message	With COM																														
	EX1	EX2	EX3	EX4*																											
No.1	OFF	OFF	OFF	For triaccer 																											
No.2	ON	OFF	OFF																												
No.3	OFF	ON	OFF																												
No.4	ON	ON	OFF																												
No.5	OFF	OFF	ON																												

13. REMOTE CONTACTS

13.1 Remote Contacts Functions

ON: Short OFF: Open

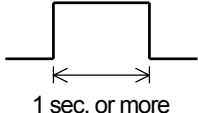
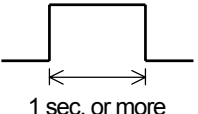
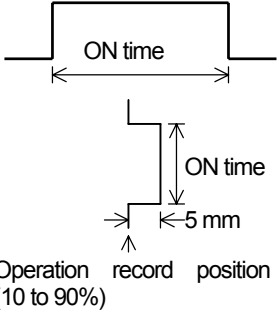
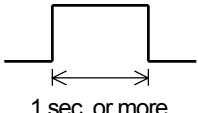
Functions	Contact signal at terminal										
<p>(3) Execution of message printing (No.1 and 2)</p>	<p>• Program messages first. See Section 11.10.</p> <table border="1" data-bbox="627 371 1291 573"> <thead> <tr> <th rowspan="2">Message</th> <th colspan="2">COM</th> </tr> <tr> <th>EX1</th> <th>EX2*</th> </tr> </thead> <tbody> <tr> <td>No.1</td> <td>OFF</td> <td rowspan="2"> For trigger  </td> </tr> <tr> <td>No.2</td> <td>ON</td> </tr> </tbody> </table> <p>* When the trigger signals is sent (for 1 sec. or more) after selecting the message No., the printing of programmed message starts. (Note) Program "Printing on/off" to on with a key operation in advance. Execution of message printing with key operation is also available. See section 9.4.</p>	Message	COM		EX1	EX2*	No.1	OFF	For trigger 	No.2	ON
Message	COM										
	EX1	EX2*									
No.1	OFF	For trigger 									
No.2	ON										
<p>(4) Execution of digital data printing</p>	<p>Turn on (for 1 second or more) the terminal No. which the digital data printing is allocated. (Note 1) Program "Printing on/off" to on with a key operation in advance. Execution of message printing with key operation is also available. See Section 9.2. (Note 2) During execution, retry of the execution can be accepted just once.</p> 										
<p>(5) Execution of list printing (List 1, 2, 3)</p>	<p>Turn on (for 1 sec. or more) the terminal No. which the printing of list 1, 2 or 3 is allocated. (Note) Program "Printing on/off" to on with a key operation in advance. Execution of message printing with key operation is also available. See Section 9.3.</p> 										
<p>(6) Execution of operation record (No. A to D)</p>	<p>Programming of the operation record position is necessary. See Section 13.4.</p> <p>Turn on (for 1 sec. or more) the terminal No. which the operation record (No. A to D) is allocated. During ON time, the recording position shifts to 5 mm to the right from the programmed operation record position. (Note) Program "Printing on/off" to on with a key operation in advance.</p> 										
<p>(7) Reset of totalization</p>	<p>Available in "Totalization" (option). The totalized value can be reset at an interval time programmed. It can be reset with a contact signal, too.</p> 										

Warning Contact signal to terminals

For the contact signal applied to the remote contacts terminals, use a switch or a relay driven at 30V AC or less or 60V DC or less or a manual contact for a very light load.

13. REMOTE CONTACTS

13.2 Terminal Allocation for Operation

This explanation is only for the remote contacts (option). Press **CLEAR** and **DATA1** simultaneously for 3 seconds or more to display the "Terminal Allocation for Operation" programming screen. This allows allocation of the desired functions to terminal Nos. 1 to 4 (EX 1 to 4).

1 Programming Mode

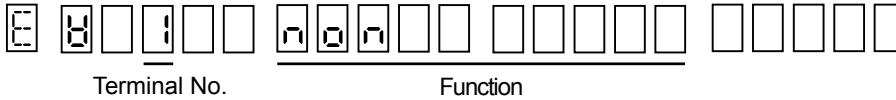

2 Programming Flow Chart

<Example> To allocate a chart speed of 3 and stop to terminal Nos. 1/2 and operation record A to terminal No. 3:

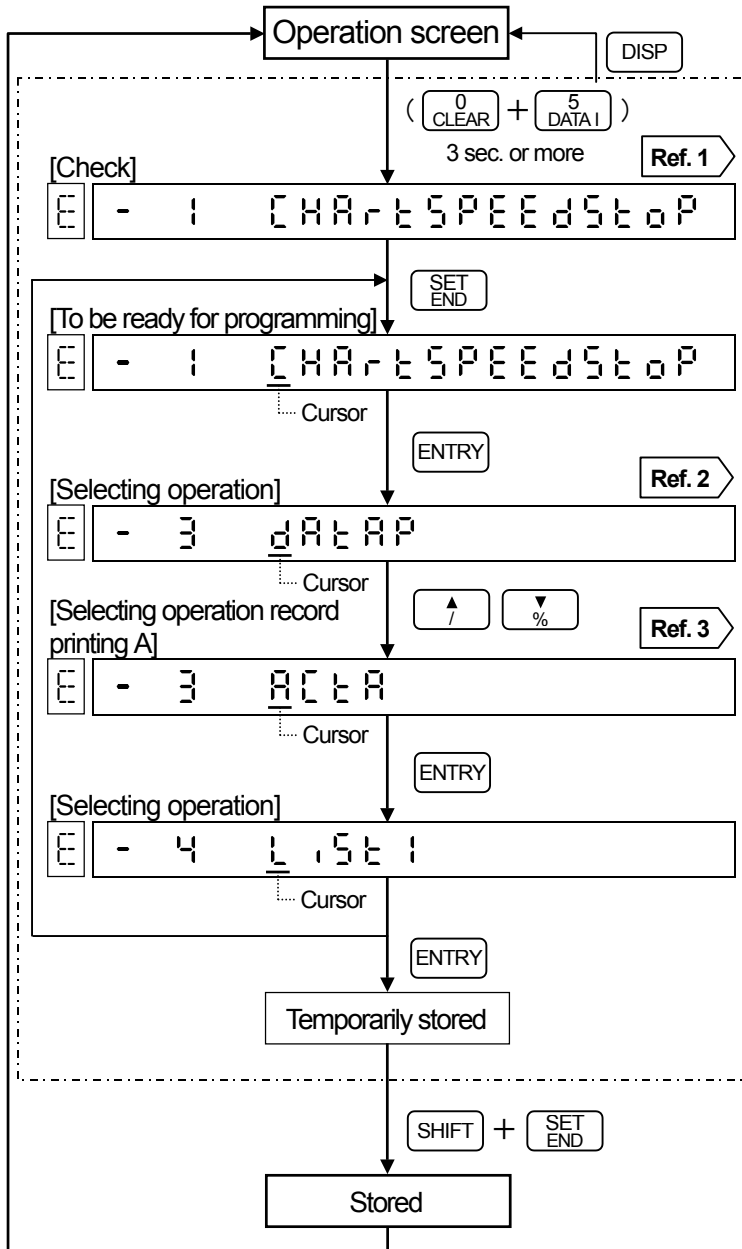

Reference 1 Checking other terminal Nos.

Press **UP** or **DOWN** to change terminal Nos. Functions allocated can be checked. The default allocation is as follows:

- Terminal No. 1: } Printing on/off and 3 chart
- Terminal No. 2: } speed selection
- Terminal No. 3: Digital data printing
- Terminal No. 4: List printing (List 1)

Reference 2 Terminal Nos. 2 to 4 are not displayed.

With **CHART SPEED**, **ASC 12** and **ASC 12.345**, the terminal Nos. are allocated automatically. Therefore, when one of these functions is selected, terminal Nos. 2 to 4 are not displayed. See Section 13.1. **1**.

Reference 3 Types of functions

Press **UP** or **DOWN** to change functions.

Displays	Details
① non	None
② CHART SPEED STOP	Printing on/off and 3 chart speed selection
③ ASC 12 ASC t r G	Message printing (No. 1 and 2)
④ ASC 12.345 ASC t r G	Message printing (No. 1 to 5)
⑤ ACtA	Operation printing A
⑥ ACtb	Operation printing B
⑦ ACtC	Operation printing C
⑧ ACtd	Operation printing D
⑨ dAtAP	Digital data printing
⑩ L iSt 1	List printing (List 1)
⑪ L iSt 2	List printing (List 2)
⑫ L iSt 3	List printing (List 3)
⑬ int rESEt	Totalization reset

13. REMOTE CONTACTS 13.3 Programming 3 Chart Speeds

The "3 chart speeds" programming screen appears only in the remote contacts (option). Press **[SHIFT]** and **[CHART]** simultaneously to display the "3 chart speeds" programming screen. Program 3 chart speeds (CS1 to 3) and select the desired speed with a contact signal. See section 13.1**2**.

3 Programming Mode

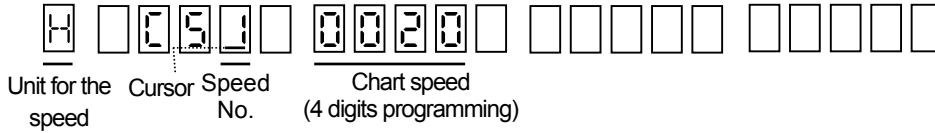

4 Programming Flow Chart

<Example> From 20 mm/h to 40 mm/h for CS2

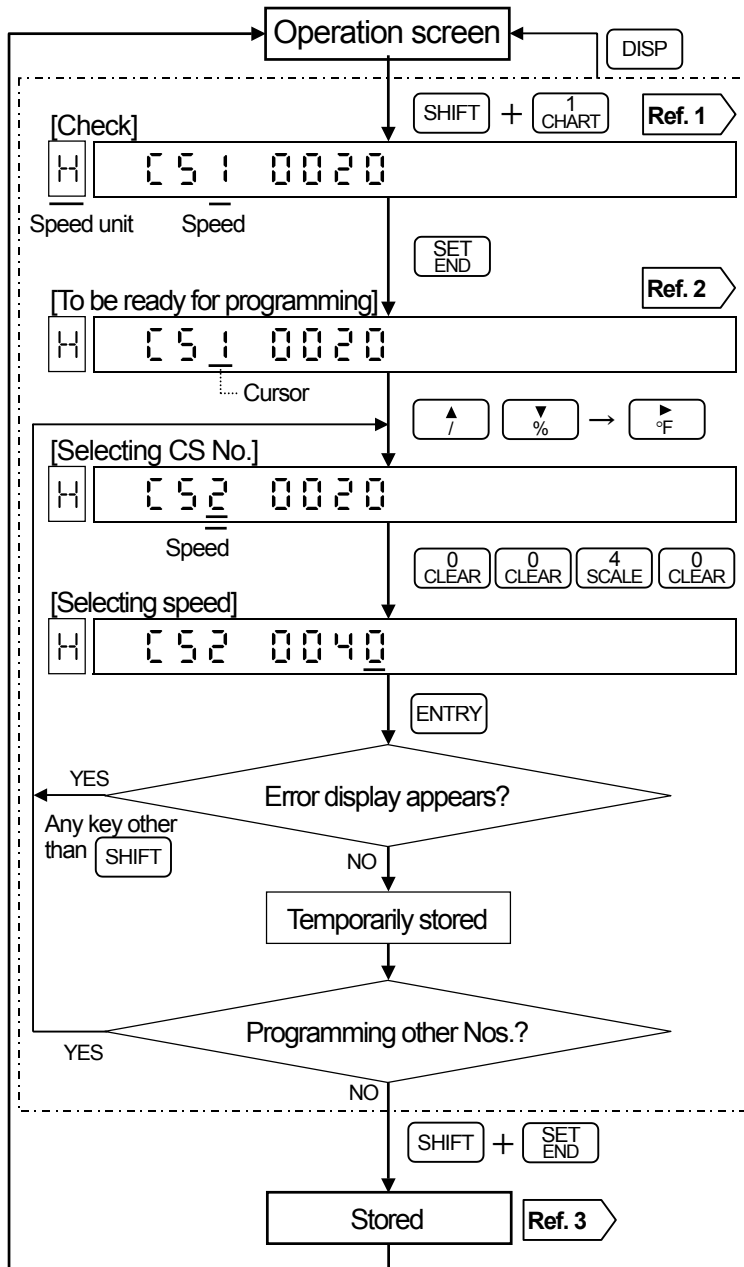

Defaults parameters and programming range

Default: 20 (AL3000), 25 (AH3000)
 Programming range: 0001 to 0600 (mm/h) or 0001 to 0200 (mm/min.)
 0000mm/h can be set for AH3000.
 When 0000mm/h is set, chart is fed at the speed of 12.5mm/h.

Remarks 1

If the chart speed is programmed at 151 mm/h or faster;

All printings except time line, digital data printing and programming change mark will not be executed. See Section 10.1.

Remarks 2

Influence to periodic data printing

If the chart speed is changed, the parameters programmed in the [Periodic data printing] (Section 11.7) is cleared.

Reference 1

Other speed No. check

Press **[↑]** or **[↓]** to change CS No. Chart speeds can be checked.

Reference 2

Changing the speed unit (h/min.)

Place the cursor on the character display (left digit) and press **[↑]** or **[↓]** to switch [M] and [H] alternately.

Reference 3

Storing

Store the [temporarily stored] parameters into memory. (Programming change mark is printed.)

13. REMOTE CONTACTS

13.4 Programming Operation Record Position

This explanation is only for the remote contacts (option). Press $\left[\begin{smallmatrix} 0 \\ \text{CLEAR} \end{smallmatrix} \right]$ and $\left[\begin{smallmatrix} 2 \\ \text{TAG} \end{smallmatrix} \right]$ simultaneously for 3 seconds or more to display the "Operation printing position" programming screen. Printing Nos. are A, B, C and D. The default values are A = 20, B = 40, C = 60 and D = 80.

1 Operation Record

The programmed recording positions are recorded by the plotter pen. When the contact signal is shorted, the recording position shifts to 5 mm to the right from the programmed operation record position. The record Nos. (A to D) are also recorded at a fixed interval.

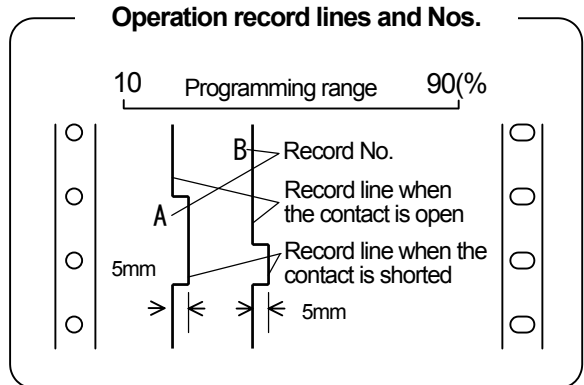

2 Programming Mode

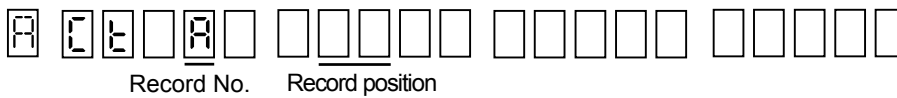

3 Programming Flow Chart

<Example> Setting of the record position of record No. B to 40%

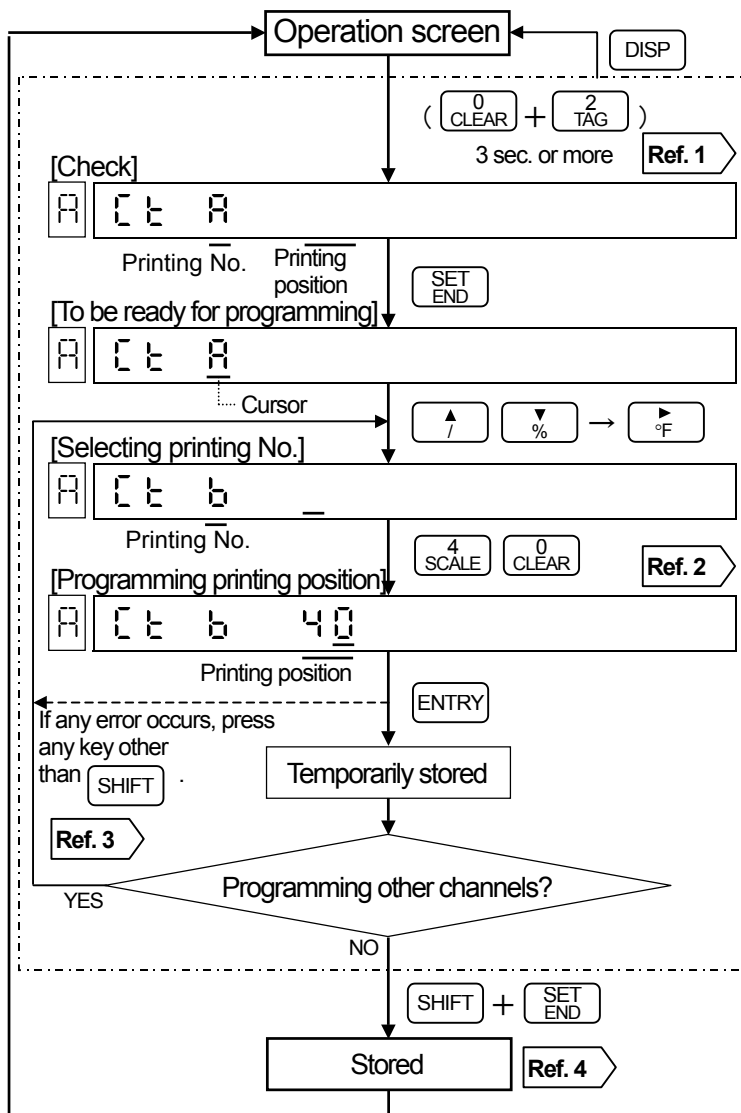

Remarks The terminal allocation is necessary.

For operation record, the "Terminal Allocation for Operation", allocations of record Nos. (A to D) to terminal Nos. (EX 1 to EX 4), is necessary. See Section 13.2.

Reference 1 Other speed No. check

Press $\left[\begin{smallmatrix} \uparrow \\ \% \end{smallmatrix} \right]$ or $\left[\begin{smallmatrix} \downarrow \\ \% \end{smallmatrix} \right]$ to change record Nos. record positions can be checked.

Reference 2 Record position range

Record position is programmable from 10% to 90% of the printing range.

Reference 3 Error display

Error is displayed when the programmed value is between 0% and 9% or between 91% and 99%.

Reference 4 Storing

Store the [temporarily stored] parameters into memory. (Programming change mark is printed.)

MEMO

A large, empty rectangular frame with rounded corners, intended for writing a memo. The frame is defined by a thin, dark border. The interior of the frame is completely blank, providing a space for the user to write their memo.

14. PRINTING FORMAT

14.1 Programming Automatic Range-Shift Printing

This programming display only appears for the printing format (option). This programming is to change the trace printing range automatically.

1 Automatic Range-shift

The automatic range-shift function changes the trace printing range up to 5 stages according to the measured values.

- (1) This programming can be applied to each channel.
- (2) The total printing range can be programmed optionally irrespective of the programmed range in the [Range/Printing range].
- (3) For each range, refer to the minimum printing range in section 22.1 (Input Specifications). The printing may be dispersed if each range is programmed to be less than the minimum printing range.
- (4) The range shifting is executed when the measured value exceeds approx. 0.5 mm from the minimum (zero) or the maximum (span) range.

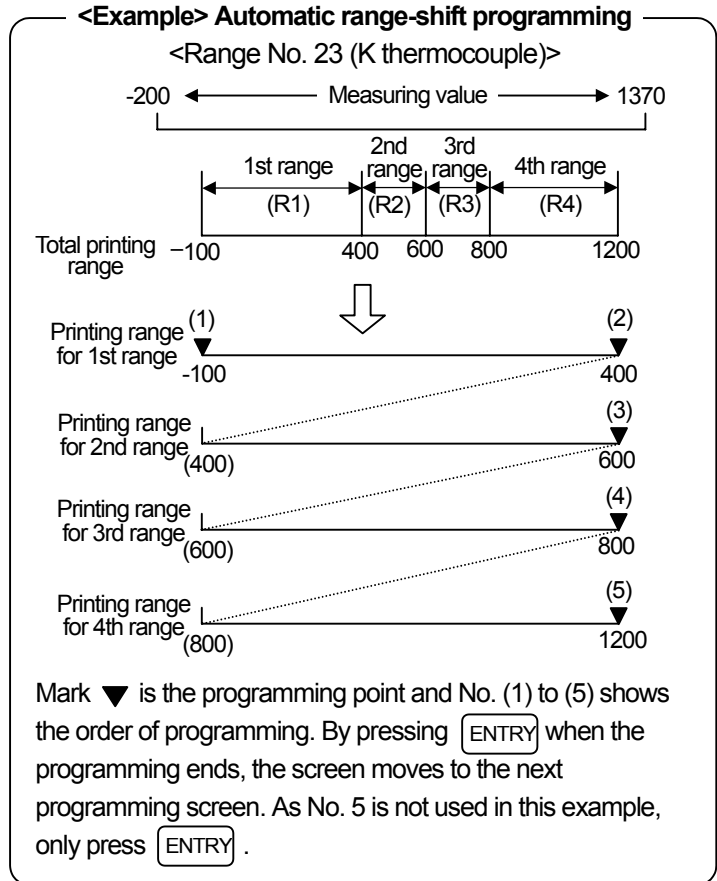

2 Programming Mode

1) Screen 1 (Printing format check)

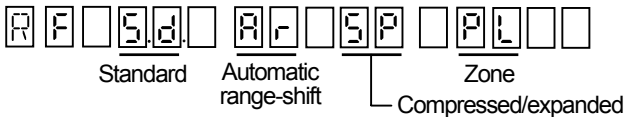

Dots appear at the selected format.

By pressing **SET END**, the dots disappear and the cursor appears instead.

2) Screen 2 (Programming channel)

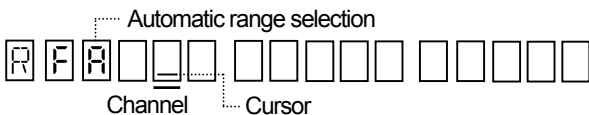

By selecting automatic range-shift (R r), the cursor appears at the channel programming position.

3) Screen 3 (Zero programming at No.1 range)

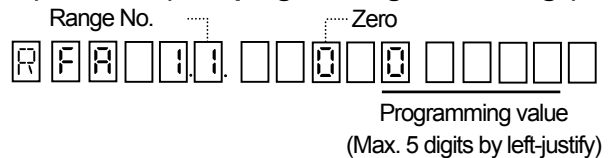

- (1) The default programmed value is the minimum value in the [Range/Printing range]. This programming can be changed as required.
- (2) When all programming are completed, return to the above display and execute [Storing].

4) Screen 4 (Span programming at No. 1 to 5 ranges)

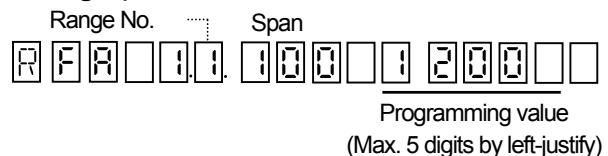

- (1) When the programming a span, the range number advances. Program the span up to the required range number.
- (2) After pressing **ENTRY** up to range No.5, press **ENTRY** again to return to Display 3.

14. PRINTING FORMAT

14.1 Programming Automatic Range-Shift Printing

3 Programming Flow Chart <Example> Programming the details on the left page for CH 1

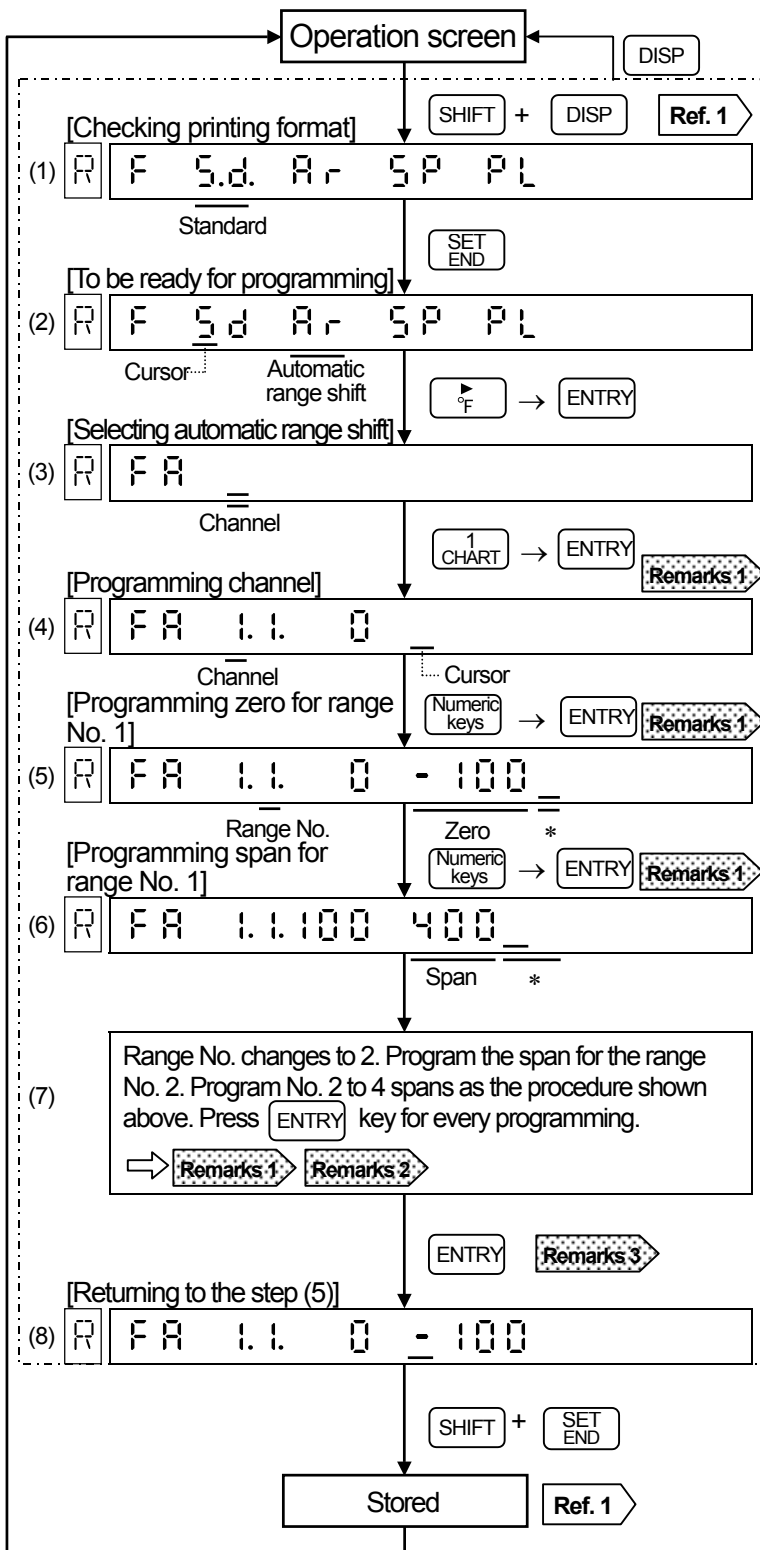

Remarks 1 Remedial measure to error display
Press any key other than [SHIFT] and program again. When it is normal, the next screen appears.

Remarks 2 Programming for the range No. 2 to No. 5
Program the span and press [ENTRY] to advance the range Nos. The range No. advances up to No. 5. For the range No. which no span programming is required, press [ENTRY] key to skip it.

Remarks 3 Return to the screen of Step (5)
For storing parameters into memory, return the screen to Step (5).

Reference 1 Checking parameters
Press [ENTRY] to display parameters. The parameters are displayed sequentially each time [ENTRY] is pressed. Press [↑] or [↓] to change channels.

Reference 2 Storing
Store the parameters into memory. (Programming change mark is printed.)

Reference 3 Cancellation of programming
For canceling the stored parameters, press [SHIFT] and [0 CLEAR] simultaneously at Steps (4) to (7), and then press [ENTRY] to store the cancellation.

Reference 4 Returning to standard printing
Point the cursor to (S d) at Step (2) and press [ENTRY]. To return to the automatic range-shift function, execute the procedure of Steps (1) to (3) and store it.

Reference 5 Scale printing at fixed-time printing
Scale is printed in the order of channels. Range Nos. (R1 to R5) are also printed.

Other channel programming
This programming is for each channel. For programming other channels, repeat the procedure from the [Operation screen].

* Fill unused digits with spaces.

14. PRINTING FORMAT

14.2 Programming Compressed/Expanded Printing

This programming display only appears for the printing format (option). This programming is to print the specified range in the [compressed/expanded] printing mode.

1 Compressed/Expanded printing

A specified range in the trace printing range can be printed in the compressed or expanded printing mode.

- (1) This programming can be executed for each channel.
- (2) The printing range can be programmed optionally irrespective of the programmed range in the [Range/Printing range].
- (3) Up to 2 break points can be programmed.

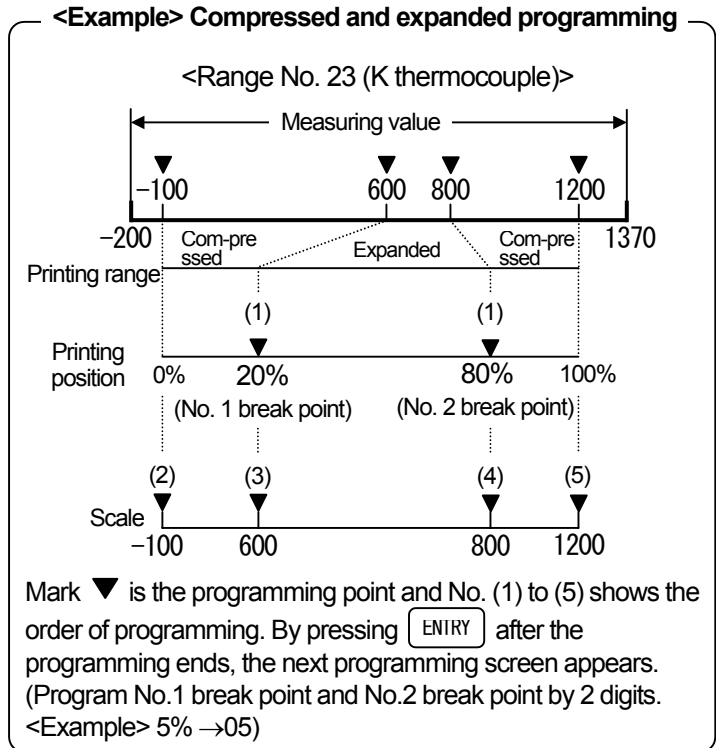

2 Programming Mode

1) Screen 1 (Printing format check)

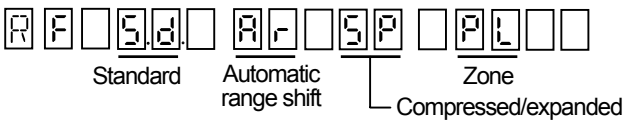

Dots appear at the selected format.

By pressing **SET/END**, the dots disappear and the cursor appears instead.

2) Screen 2 (Programming channel)

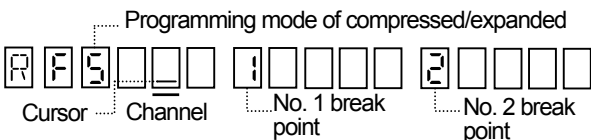

By selecting compressed/expanded (SP), the cursor appears at the channel programming position.

3) Screen 3 (Programming break point printing position)

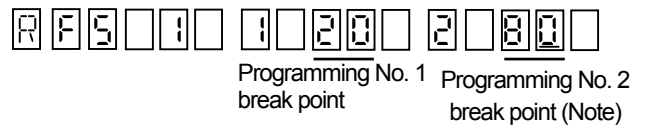

- (1) Program each break point printing position (%) in the range of 10 to 90.
- (2) When all programming are completed, return to the above display and execute [Storing].
- (Note) No.1 break point should be lower than No.2 break point. When no programming for the No.2 break point is required, leave it as spaces.

4) Screen 4 (Scale programming of each printing position)

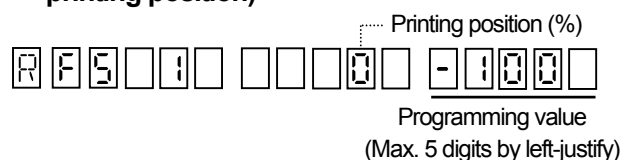

- (1) When programming a scale, the printing position advances to the next position. Program scales up to the 100% position.
- (2) After completing the programming for 100%, press **ENTRY** to return to Screen 3.

3 Programming Flow Chart <Example> Programming the details on the left page for CH 2

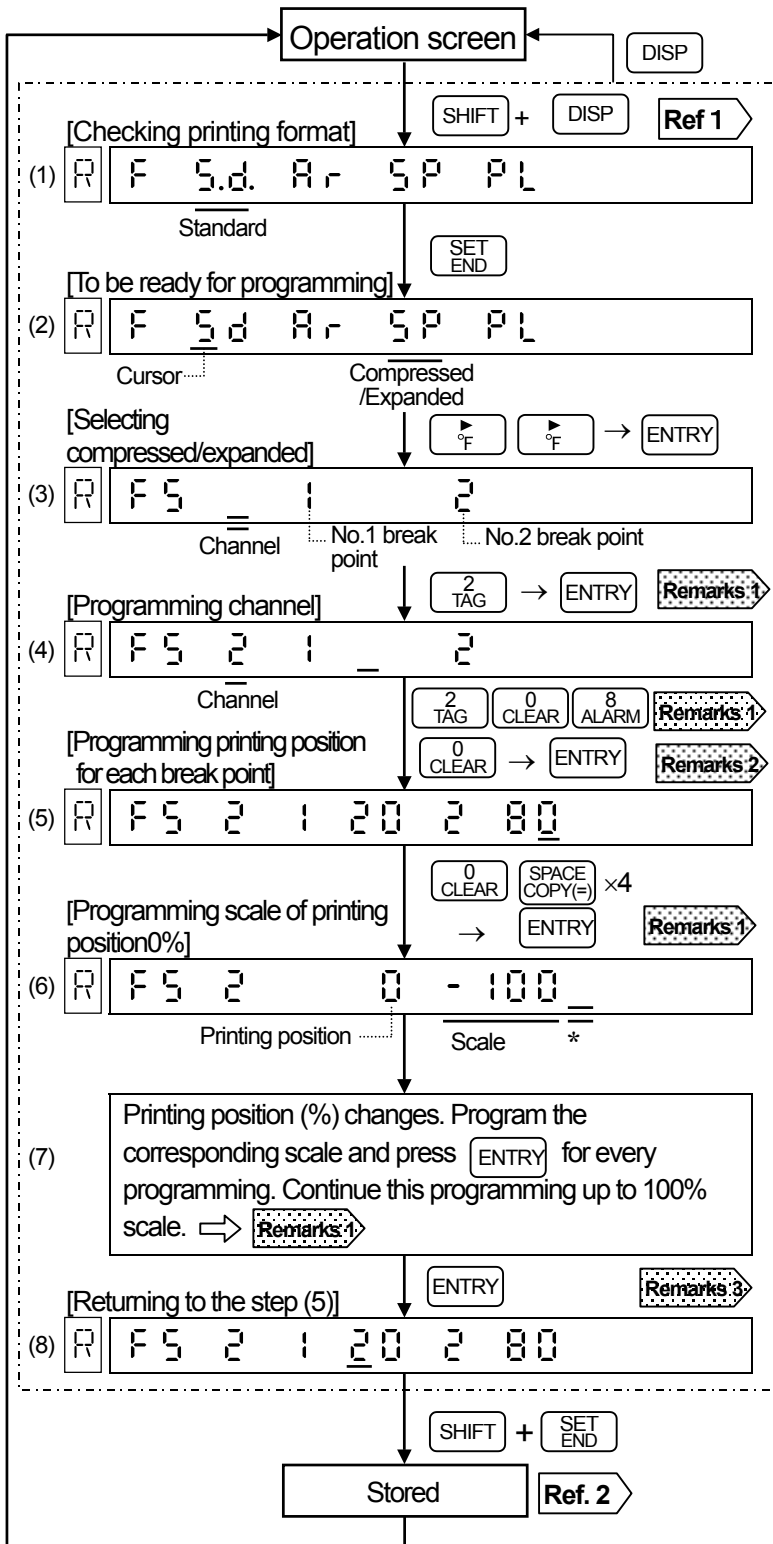

Remarks 1 Remedial measure to error display
Press any key other than [SHIFT] and program again. When it is normal, the next screen appears.

Remarks 2 No programming of No. 2 break point necessary
Leave it as spaces and press [ENTRY].

Remarks 3 Return to the screen of Step (5)
For storing parameters into memory, return the screen to Step (5).

Reference 1 Checking parameters
Press [ENTRY] to display parameters. The parameters are displayed sequentially each time [ENTRY] is pressed. Press [↑] or [↓] to change channels.

Reference 2 Storing
Store the parameters into memory. (Programming change mark is printed.)

Reference 3 Cancellation of programming
For canceling the stored parameters, press [SHIFT] and [0 CLEAR] simultaneously at Steps (4) to (7), and then press [ENTRY] to store the cancellation.

Reference 4 Returning to standard printing
Point the cursor to (S d) at Step (2) and press [ENTRY]. To return to the compressed/expanded function, execute the procedure of Steps (1) to (3) and store it.

Reference 5 Scale printing at fixed time printing
Scales at each printing position are printed like as -100, 600, 800 or 1200.
• "+" mark is printed at the printing position for break points.

Other channel programming

This programming is necessary for each channel. For programming other channels, repeat the procedure from the "Operation screen".

* Fill unused digits with spaces.

14. PRINTING FORMAT 14.3 Programming Zone Printing

This programming display only appears for the printing format (option). This programming is to print the printing area by dividing it into 2 to 4 zones. (AL3000: 2 zones only)

1 Zone Printing

The printing area is divided into two zones (AL3000) or four zones (AH3000) and the printing zone can be selected. This function is effective when printings overlap each other.

- (1) The printing zone can be selected for each channel.
- (2) The printing range for each zone is the programmed printing range in the [Range/Printing range].
- (3) The followings are printing position (mm) at the number of zone.

• AL3000

Zone No. 1	0 to 45
Zone No. 2	55 to 100

• AH3000

Zone	Zone No.1	Zone No.2	Zone No.3	Zone No.4
2	0 to 81	99 to 180		
3	0 to 54	63 to 117	126 to 180	
4	0 to 36	45 to 81	99 to 135	144 to 180

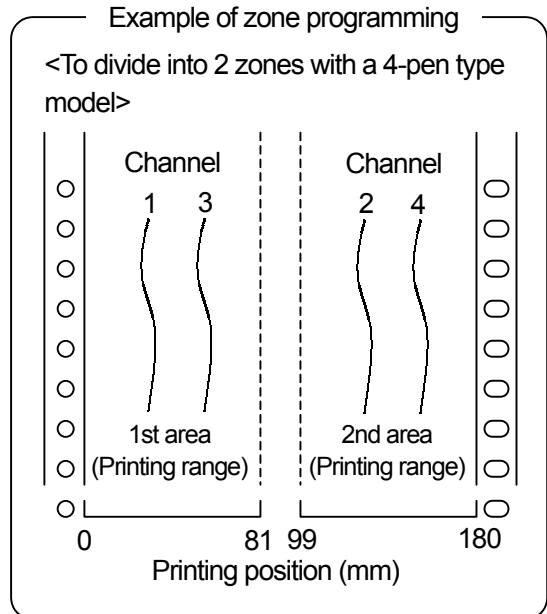

2 Programming Mode

1) Screen 1 (Printing format check)

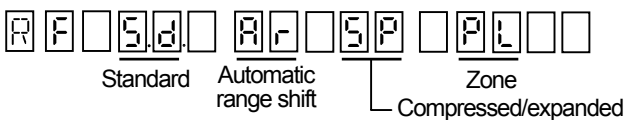

Dots appear at the selected format.

By pressing **SET/END**, the dots disappear and the cursor appears instead.

2) Screen 2 (Programming number of zones)

... Displays in AH3000 only

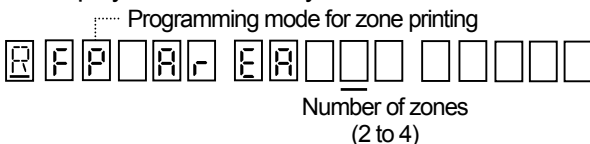

(Note) For AL3000 (2 zones only), Screen 2 is skipped and Screen 3 appears.

3) Screen 3 (Programming channel for zone No.1)

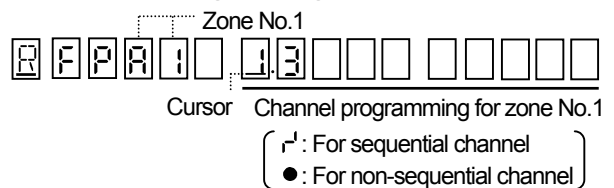

4) Screen 4 (Programming channel for zone Nos. 2 to 4)

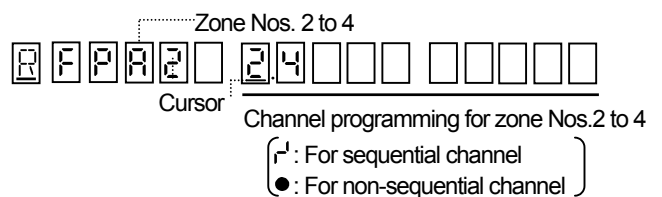

(Note) The programming for zones No. 3 and 4 are for AH3000 only.

14. PRINTING FORMAT

14.3 Programming Zone Printing

3 Programming Flow Chart (AL3000)

<Example> Programming CH 1 and CH 3 to zone No.1, and CH 2 and CH 4 to zone No. 2

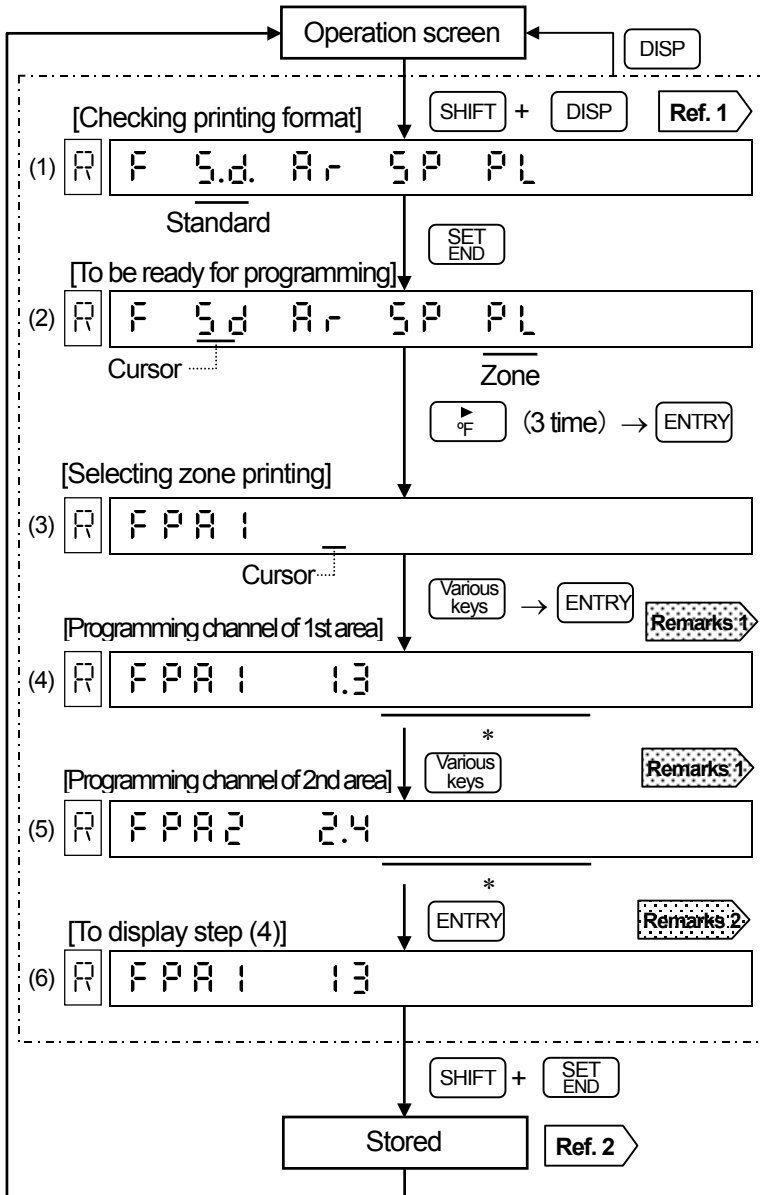

Remarks 1 Remedial measure to error display

Press any key other than **SHIFT** and program again. When it is normal, the next screen appears.

Remarks 2 Return to the screen of Step (4)

For storing parameters into memory, return the screen to Step (4).

Remarks 3 Selection and overlapping of channels

The channel not selected in any zone is skipped. Also, if the selection of channel is overlapped or the skipped channel is selected, error display appears.

Reference 1 Checking parameters

Press **ENTRY** to display parameters. The parameters are displayed sequentially each time **ENTRY** is pressed.

Reference 2 Storing

Store the parameters into memory. (Programming change mark is printed.)

Reference 3 Border mark

"+" mark is printed at the border of the area.

*Fill unused digits with spaces.

14. PRINTING FORMAT

14.3 Programming Zone Printing

4 Programming Flow Chart (AH3000)

<Example> Programming CH 1 and CH 3 to zone No.1, and CH 2 and CH 4 to zone No. 2

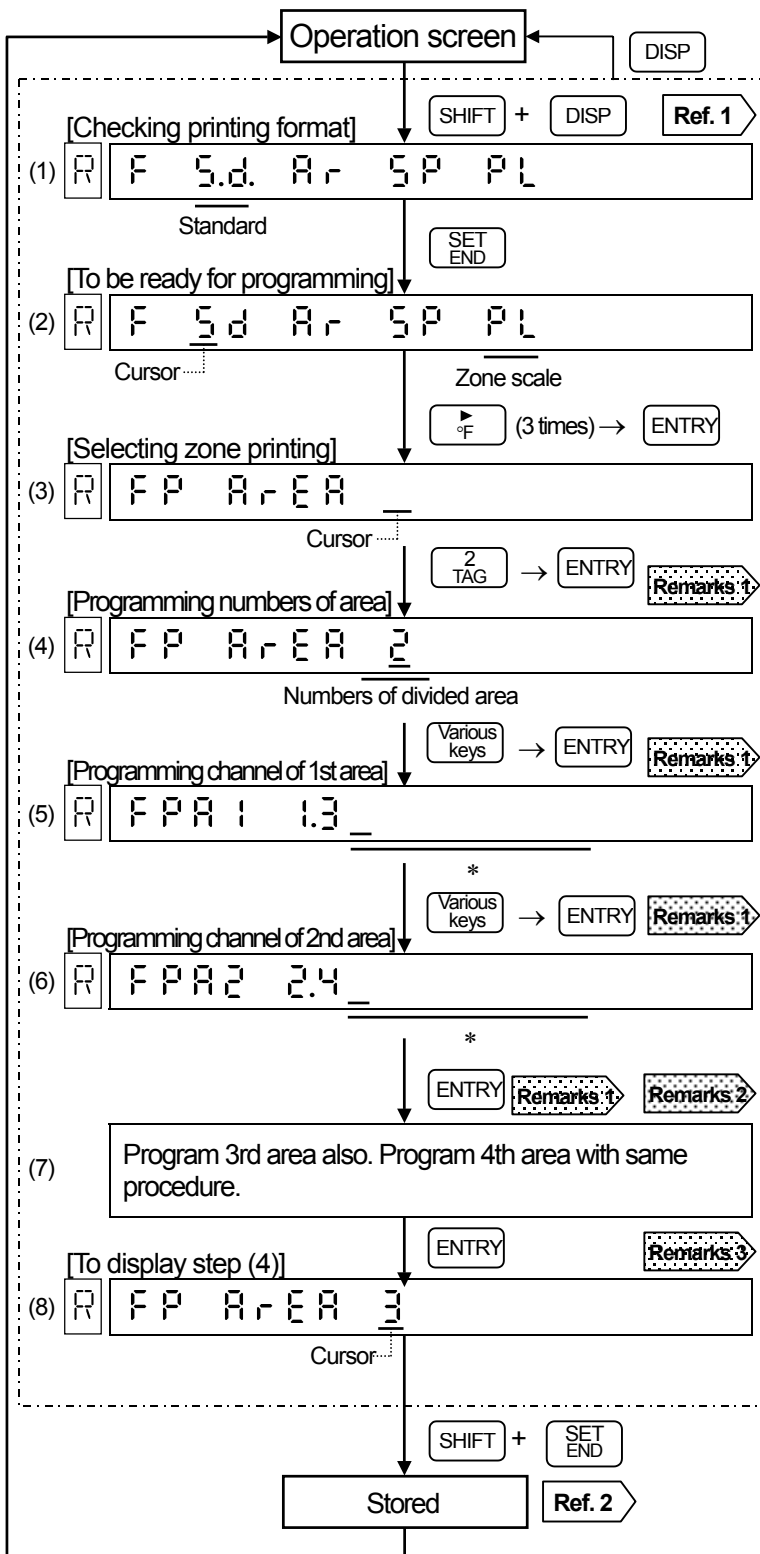

Remarks 1 Remedial measure to error display
If error display appears during programming, press any key other than **SHIFT** and program again. When it is normal, the next screen appears.

Remarks 2 Channels programming for 3rd or 4th zones
When zones are divided into 3 or 4, program channels up to 3 or 4 zones.

Remarks 3 Return to the display of Step (4)
For storing the parameter into memory, return the screen to Step (4).

Remarks 4 Selection and overlapping of channels
The channel not selected in any zone is skipped. Also, if the selection of channel is overlapped or the skipped channel is selected, error display appears.

Reference 1 Checking parameters
Press **ENTRY** to display parameters. The parameters are displayed sequentially each time **ENTRY** is pressed.

Reference 2 Storing
Store the parameters into memory. (Programming change mark is printed.)

Reference 3 Border mark
“+” mark is printed at the border of the area.

* Fill unused digits with spaces.

15. COMMUNICATIONS INTERFACE

15.1 Programming communications Protocol

This explanation is only for the communications interface (option). Press **SHIFT** and **SPACE COPY(=)** simultaneously for 3 seconds or more to display the “communications protocol” programming screen.

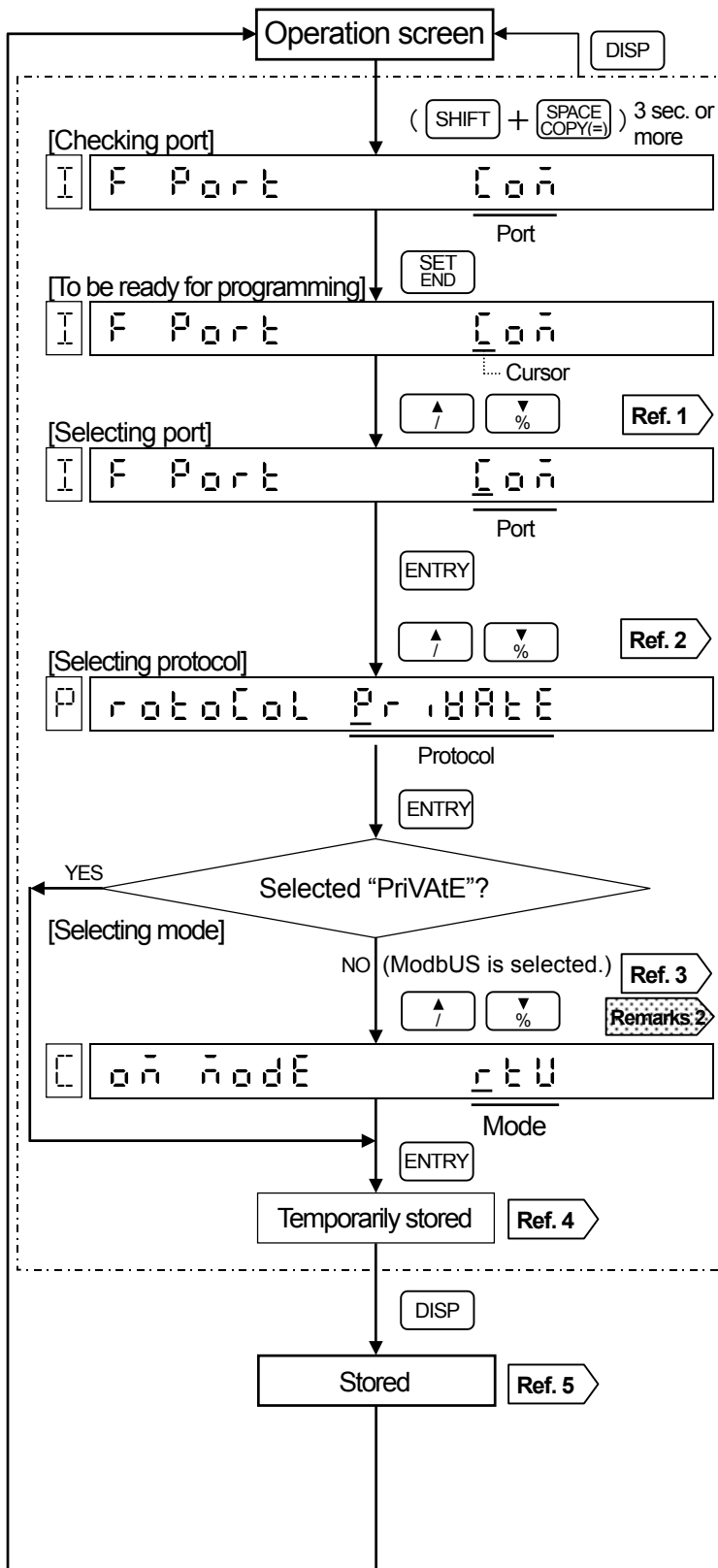

Remarks 1 Communications interface

This section only explains programming of the communications interface. For details of the communications interface, refer to the separate instruction manual for “Communications Interface”.

Remarks 2

When EnG is selected and then MODBUS is selected, it is fixed to RTU mode.

Reference 1 Port selection

Select the port type from the followings.

- (1) C o n : Higher level communications
- (2) E n G : Engineering

Reference 2 Protocol selection

Select the protocol from the followings.

- (1) P r i V A t E : Private protocol
- (2) M o d b u s : MODBUS protocol

Reference 3 Mode selection

When [M o d b u s] is selected, the mode selection screen is displayed. Select the mode from the followings.

- (1) r t u : RTU mode
- (2) A S C I I : ASCII mode

Reference 4 Return to the port selection screen

After “temporarily storage”, the “Port selection” screen appears again. For storing parameters, press **DISP**.

Reference 5 Storing

Store the [temporarily stored] parameters into memory. (Programming change mark is printed.)

15. COMMUNICATIONS INTERFACE 15.2 Programming communications

This explanation is only for the communications interface (option). Press **SHIFT** and **⏏** simultaneously for 3 seconds or more to display the “communications” programming screen.

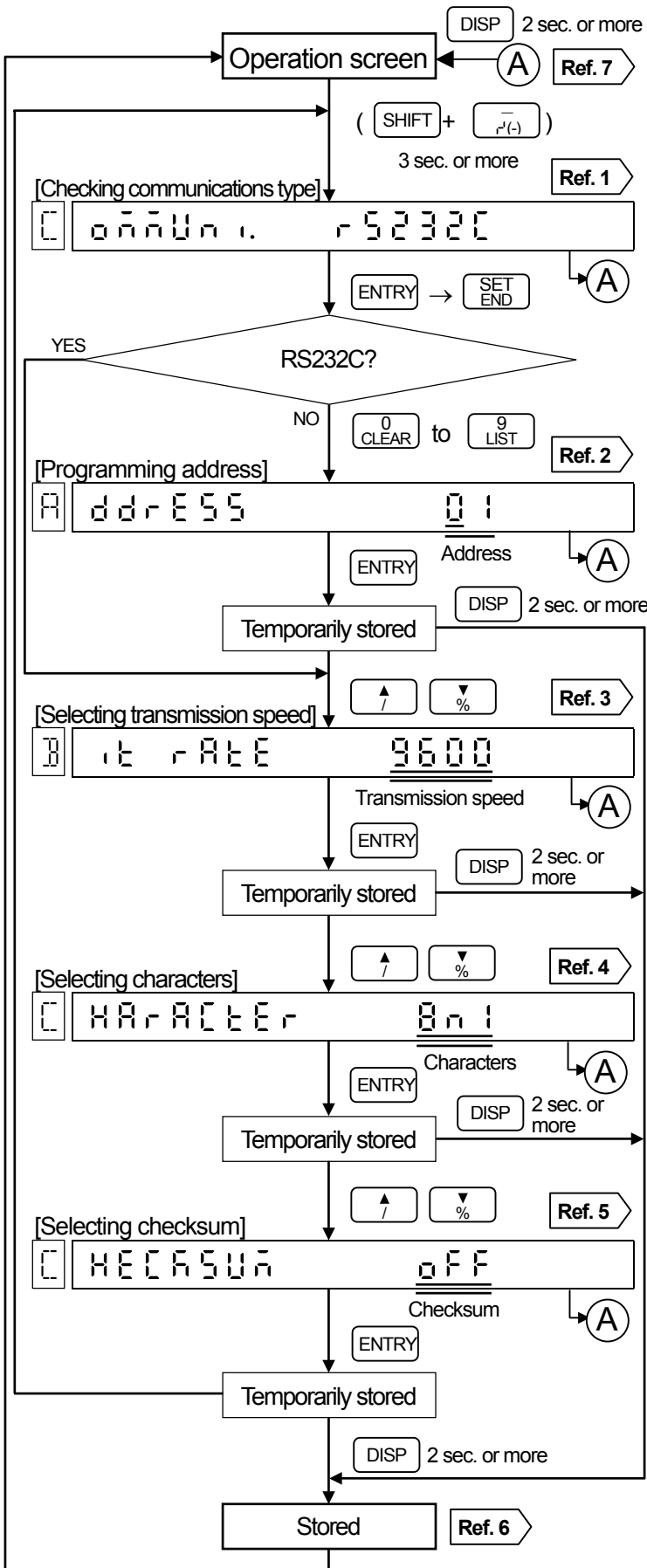

Reference 1 Communications type check

Communications type is displayed. The communications type cannot be changed.

Reference 2 Address programming range

01 to 99: PRIVATE (private) protocol
 01 to 31: MODBUS (MODBUS) protocol
 (Note) “01” is displayed only when “private” is changed to “MODBUS”.

Reference 3 Transmission speed selection range

1200, 2400, 4800, 9600, 19200 bps
 Only 9600 and 19200 bps are available with the MODBUS protocol.
 (Note) “9600” is displayed only when “private” is changed to “MODBUS”.

Reference 4 Character selection

Characters are displayed with codes.

Code	Character length	Parity	Stop bit
7E1	7 bits	Even	1
7E2	7 bits	Even	2
7O1	7 bits	Odd	1
7O2	7 bits	Odd	2
8N1	8 bits	Non	1
8N2	8 bits	Non	2
8E1	8 bits	Even	1
8E2	8 bits	Even	2
8O1	8 bits	Odd	1
8O2	8 bits	Odd	2

(Note) “8N1” is displayed only when “private” is changed to “MODBUS”.

Reference 5 Checksum selection range

ON : Checksum ON
 OFF : Checksum OFF
 (Note) No display appears for the MODBUS protocol.

Reference 6 From “temporarily stored” to “stored”

Pressing **ENTRY** for each programming executes temporary storing. Pressing **DISP** for 2 seconds or more executes storing and returns to the operation screen.

Reference 7 Returning to operation screen

If the screen returns to the operation screen before pressing **ENTRY**, the parameter is returned to the parameter before programming.

16. Math Expressions and Totalization

Remarks Math expressions and totalization

This section outlines math expressions and totalization. For programming, read the separate instruction manual for “Math Expressions and Totalizations (Option)”.

1 Math Expressions

- (1) Measured values are computed and the results are displayed and stored into memory.
- (2) Math expressions comprise basic calculations, totalization, flow rates, etc., which are depending on the relevant model code.
- (3) 18 types of math expressions are provided and they can be programmed to any channel.

	Display characters	Names	Remarks
Basic calculation	(1) none	None	No computation (Display and printing of measured values)
	(2) + - x	Arithmetical operation 1	+ , - , x (Aax + By + Cxy + D)
	(3) ÷	Arithmetical operation 2	÷ (Ax/y + B)
	(4) Ln	Natural Logarithm	LoG _e X
	(5) Log	Logarithm	LoG ₁₀ X
	(6) P o w e r	Exponential	e ^x
	(7) r o o t	Square root	$\sqrt{Rx - Rz/Rs - Rz}$ Rs: Max. range, Rz: Min. range
	(8) H U n d i e t y	Temperature/ humidity	Computation of measured values by the dry and wet bulbs by using the relative humidity tables
	(9) M a x	Maximum	Maximum value at the programmed “interval period”
	(10) M i n	Minimum	Minimum value at the programmed “interval period”
	(11) A v e r a g e	Average value	Average value at the programmed “interval period”
	(12) A b s	Totalizing	X
	(13) C o m m u n i c a t i o n	Data communications input	Displayed only for the communications Interface (option)
Totalization, flow rate, etc.	(14) i n t	Totalization	Displayed only for the totalization (option)
	(15) F l o w c o r r e c t i o n 1	Flow correction computation 1	
	§	§	
	(21) F l o w c o r r e c t i o n 7	Flow correction computation 7	

2 Totalizing

- (1) Measured values and computed results are totalized and the results are displayed and printed. The reset of the totalization is executed with the programmed interval or a contact signal for the “remote contacts” (option).
- (2) Totalization is displayed as “int”. This can be programmed to any channel.

3 Instruction manual

An instruction manual (INST. No. INE-288) for “Math expression and totalization (option)” is attached separately.

17. Other Options

17.1 Shunt Resistor for Current Input

DC current input can be measured by attaching a shunt resistor (option) to the input terminals.

1 Shunt resistor (Option) and Measurement current range

- A shunt resistor converts the DC current input into a DC voltage. The two types shown in the right table are available.
- The current measuring ranges are shown in the right table, too.

2 Connection

Connect a shunt resistor to each channel for the DC current measurement.

Remarks Caution on connections

Only one shunt resistor is to be connected to a channel.

3 [Range/Printing range] and [Scale]

1) Range No.

The converted voltage with any shunt resistor is ± 5 V DC and the range No. is "07".

2) Printing range

Program the printing range with the value after being converted into a voltage.

- Minimum value:
Min. input current x shunt resistor value
- Maximum value:
Max. input current x shunt resistor value

3) Scale

Program the scale with the physical quantity against the input current.

- Minimum value:
Physical quantity of the minimum input current
- Maximum value:
Physical quantity of the maximum input current

Shunt resistor and measuring range

Code	Resistance value*	Measuring range
EZ-RX100	100 Ω	± 50 mA DC
EZ-RX250	250 Ω	± 20 mA DC

Accuracy: 100 Ω - Rated value $\pm 0.05\%$
250 Ω - Rated value $\pm 0.1\%$

Ex) Connection of a shunt resistor to CH1

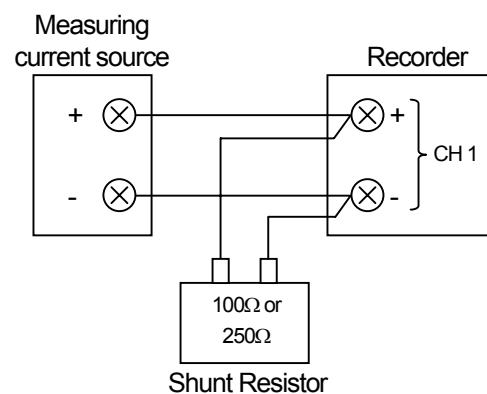

Using Range No.

Resistance value	Measuring range	Converted voltage	Range No.
100 Ω	± 50 mA DC	± 5 VDC	07
250 Ω	± 20 mA DC	± 5 VDC	07

Example of printing range

<Input to be printed with the trace printing: 4 to 20mA>

Use the shunt resistor of 250 Ω for the maximum measuring current of 20mA.

- Minimum value: 4 (mA) x 250 (Ω) = 1 (V)
- Maximum value: 20 (mA) x 250 (Ω) = 5 (V)

Example of scale programming

<Physical quantity of 4 to 20mA is 0 to 500 liter/m²>

- Minimum value: 0
- Maximum value: 500

1 Transmitter Power Supply

This power supply unit, which is designed to install on the rear panel (terminal board) of the instrument, supplies power (24VDC) to a transmitter that transmits the measurement input signals to your recorder.

[Model] RZ-TPS01

[Instruction manual] INST. No. INE-277 □

18. ADJUSTMENT

18.1 Adjustment of Measured Values

■ Adjustment

Adjustment comprises four kinds shown below. (1), (3) and (4) have already been adjusted. However, it is recommended for maintaining the measuring and printing accuracy to adjust them once a year.

Calibration	Details	Reference
(1) Measured values adjustment	Adjustment to keep the measured value against input within the accuracy ratings.	Sec.18.1
(2) Shift programming of measured value	Programming to shift a measured value	Sec.18.2
(3) Adjustment of printing position	Adjustment to set the printing range to the zero and span lines on the chart	Sec.18.3
(4) Adjustment for time-axis synchronization of pens	Adjustment of the gaps between pens for the time-axis synchronization	Sec.18.4

1 Adjustment of measured values

It is recommended for maintaining measuring and printing accuracy to adjust them once a year.

- (1) Execute the adjustment for each channel.
- (2) Execute the adjustment under the reference condition. (See the right table.)

Reference conditions

Items	Reference conditions
Ambient temperature	23 ±2°C
Ambient humidity	55 ±10%RH
Power voltage	100 ±1VAC
Power supply frequency	50 or 60 ±0.5Hz

2 Preparation

1) Preparation of tools

Tools	Input types			Remarks
	DC voltage	Thermocouple	Resistance thermometer	
DC standard voltage/current generator	○	○		Accuracy: Should be better than ±0.05%.
Reference junction compensator		○		0°C ±0.2°C or less
Thermocouple for test		○		Same type of thermocouple as input type
Standard variable resistor			○	Accuracy: Should be better than ±0.05%.
3-core copper wire			○	Same resistance for each 3 cores

2) Connection

Connections depend upon the input types. See the next page.

3) Before starting adjustment

- (1) After the connection, mount the terminal board cover and turn on the power supply.
- (2) Before starting adjustments, warm up your recorder for at least 30 minutes until it becomes stable. (It is recommended to warm it up for at least one hour if possible.)

Remarks

Adjustments

Check and adjustments of the measured values need meticulous work in addition to the standard tools and reference conditions.
If you need checks or adjustments of the measured values, please consult your nearest CHINO's agent.

18. ADJUSTMENT

18.1 Adjustment of Measured Values

3 Connections

Connections depend upon the input types. Connect the standard tools to the input terminals to be adjusted.

Caution Make sure to connect after turning off the power supply.

To prevent any injury caused by electric shock, be sure to turn off the power supply before connections.

(1) In case of thermocouple input

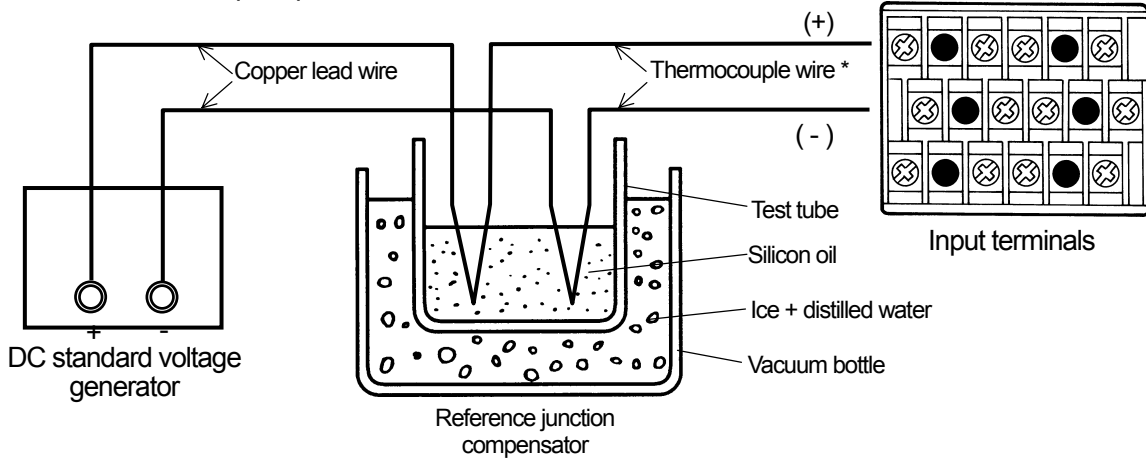

The electromotive force of the thermocouple input is reduced by an amount proportional to the temperature at the terminals. The recorder itself compensates (reference junction compensation) for this reduction. The adjustment is executed by inputs based on the reference electromotive force (0°C reference). In case the "RJ selection" is set to "1" (Enable) in the "Range/Printing range" programming, an amount equivalent to the reference junction compensation has to be subtracted using a reference junction compensator.

(2) DC voltage input

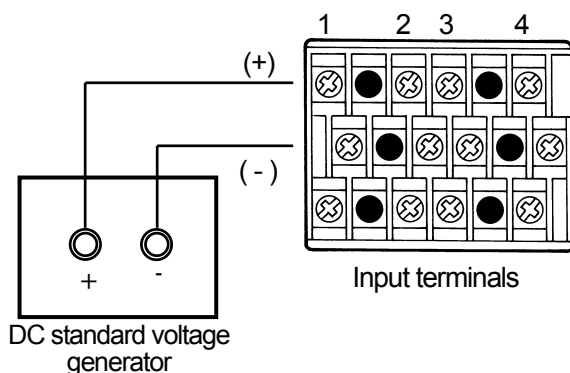

(3) Resistance thermometer input

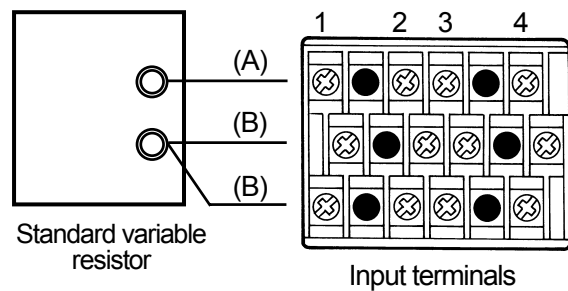

18. ADJUSTMENT

18.1 Adjustment of Measured Values

4 Programming Flow Chart

<Example> Adjustment of CH 01 (Printing range: -50 to 150)

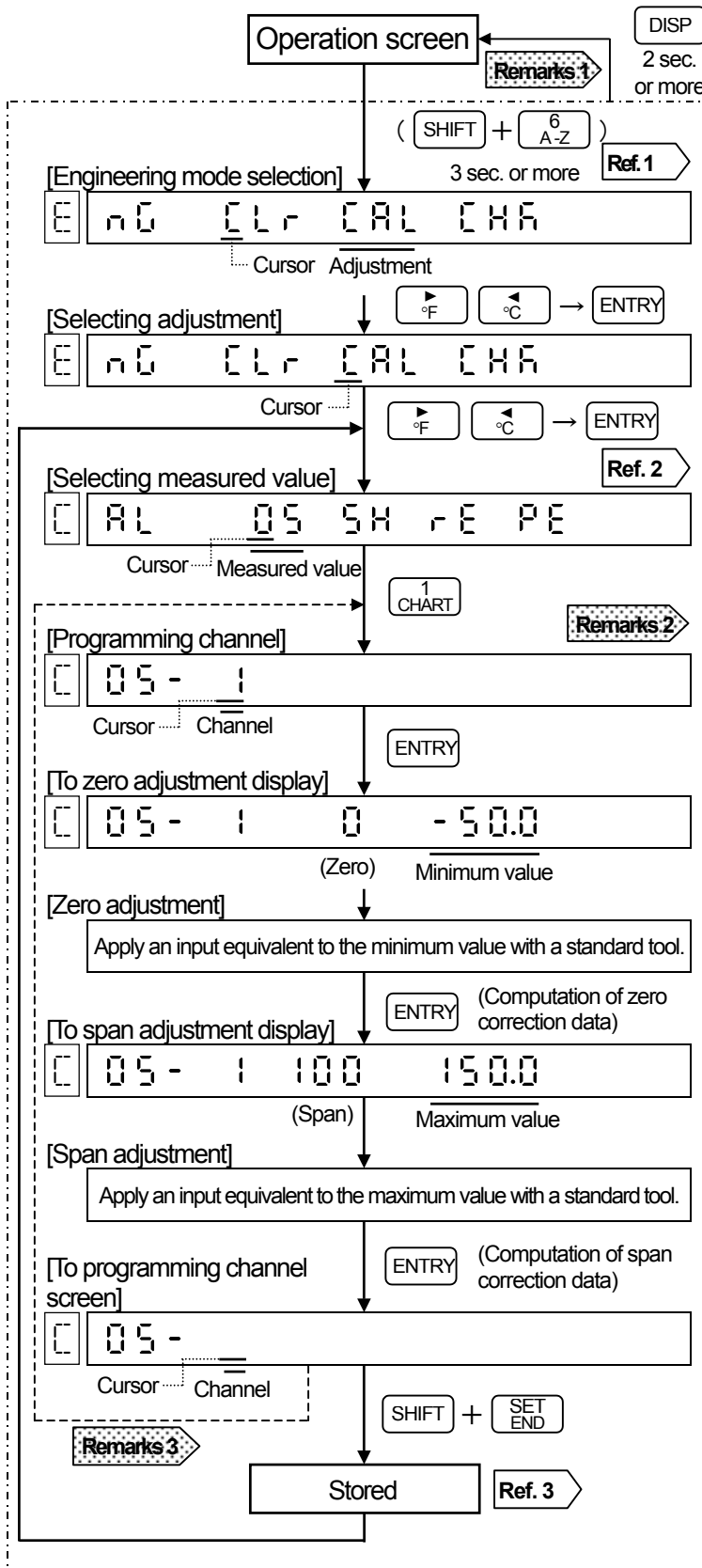

Remarks 1 By returning to the operation screen

Computed correction data are canceled if the screen is returned to the operation screen in the procedures before [Storing].

Remarks 2 Skipped channel does not accept any [ENTRY] key

When a skipped channel is programmed, [ENTRY] operation is not accepted.

Remarks 3 Other channels adjustment

Change the connection to other input terminals to be adjusted and repeat the same procedure from the programming channel screen (indicated by a dotted line).

Remarks 4 Initialization of correction data

In zero adjustment or span adjustment screen, when [SHIFT] and [CLEAR] are pressed simultaneously and then [ENTRY] is pressed, the correction data of its channel are initialized.

Reference 1 Engineering mode types

CLr : Memory clear
CAL : Adjustment
CHr : Hardware check

Reference 2 Adjustment types

05 : Measured value adjustment
SH : Shift programming for measured value
rE : Printing position adjustment
PE : Time-axis adjustment for pens

Reference 3 Storing

Store the computed correction data into memory.

18. ADJUSTMENT

18.2 Shift Programming of Measured Value

This programming is for slight-shifting a measured value. After programming, measured values are shifted by the programmed amount.

1 Shift Programming

- (1) This programming is necessary for each channel.
- (2) The cursor shifts to the least significant digit. Execute this programming with or .

2 Programming Flow Chart

<Example> Changing measured value of CH 1 from 850.3 to 850.0

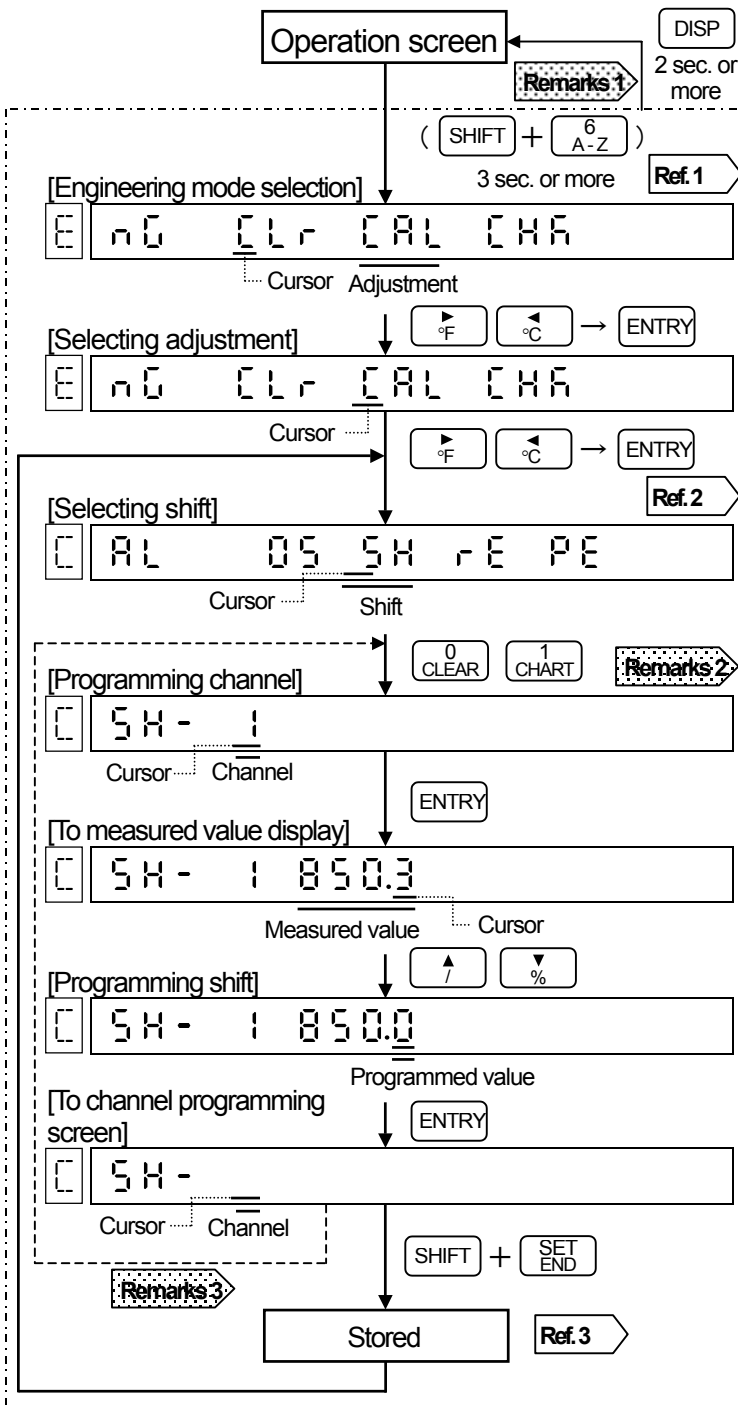

Example of shift programming

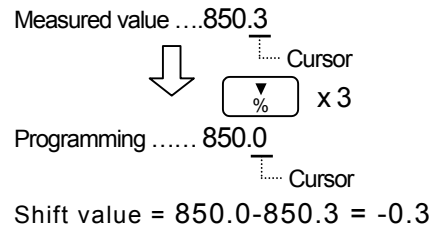

Before programming

Before starting this programming, wait for at least 30 minutes after turning on the power supply.

Remarks 1 By returning to the operation screen

Programmed shifting data is canceled if the screen is returned to the operation screen in the procedures before [Storing].

Remarks 2 Skipped channel does not accept any [ENTRY]

When a skipped channel is programmed, [ENTRY] operation is not accepted.

Remarks 3 Other channels adjustment

Change the connection to other input terminals to be adjusted and repeat the same procedure from the programming channel display (indicated by a dotted line).

Remarks 4 Initialization of shift data (0)

In zero adjustment or span adjustment screen, when [SHIFT] and [CLEAR] are pressed simultaneously and then [ENTRY] is pressed, the correction data of its channel are initialized.

Reference 1 Engineering mode types

- CLr: Memory clear
- CAL: Adjustment
- CHr: Hardware check

Reference 2 Adjustment types

- OS: Measured value adjustment
- SH: Shift programming for measured value
- rE: Printing position adjustment
- PE: Time-axis adjustment for pens

Reference 3 Storing

Store the programmed shifting data into memory.

18. ADJUSTMENT

18.3 Adjustment of Printing Position

This is the adjustment for the printing position of the cartridge pen for use in trace printing. It is recommended to adjust it once a year for maintaining the printing accuracy.

Adjustment Flow Chart

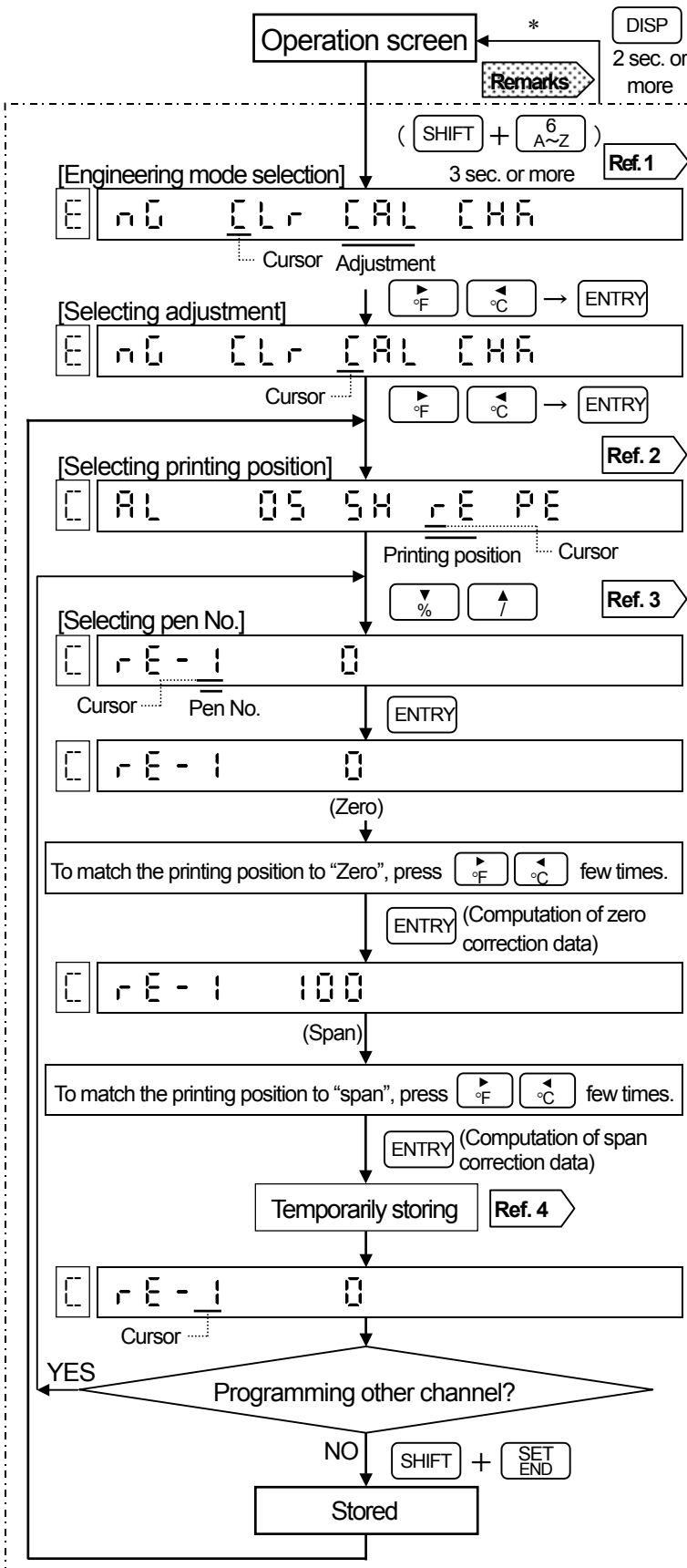

Zero/span adjustment procedure
 Pressing F once moves 0.1 mm to right. Pressing C once moves 0.1 mm to left. Press ENTRY when the printing position matches to zero or span of the chart.

Other pens than the pen being adjusted
 Pens stand by near the scale center.

Remarks By returning to the operation screen
 Computed correction data are canceled if the screen is returned to the operation screen in the procedures before [Storing].

*During zero and span adjustments, DISP operation is not accepted.

Reference 1 Engineering mode types
 CLr: Memory clear
 CAL: Adjustment
 CHk: Hardware check

Reference 2 Adjustment types
 OS: Measured value adjustment
 SH: Shift programming for measured value
 rE: Printing position adjustment
 PE: Time-axis adjustment for pens

Reference 3 Pen No.
 1: 1st pen
 2: 2nd pen (2-pen type to 4 pen type)
 3: 3rd pen (3-pen type, 4-pen type)
 4: 4th pen (4-pen type only)

Reference 4 Storing
 Store the computed correction data into memory.

18. ADJUSTMENT

18.4 Time-axis Adjustment of Pens

When the time-axis synchronization (POC) is programmed to "on", the gaps between the pens may change over time, resulting in error between their time-axis. This adjustment is for correction of these changes. It is recommended to adjust them once a year for maintaining the time-axis synchronization.

Adjustment Flow Chart

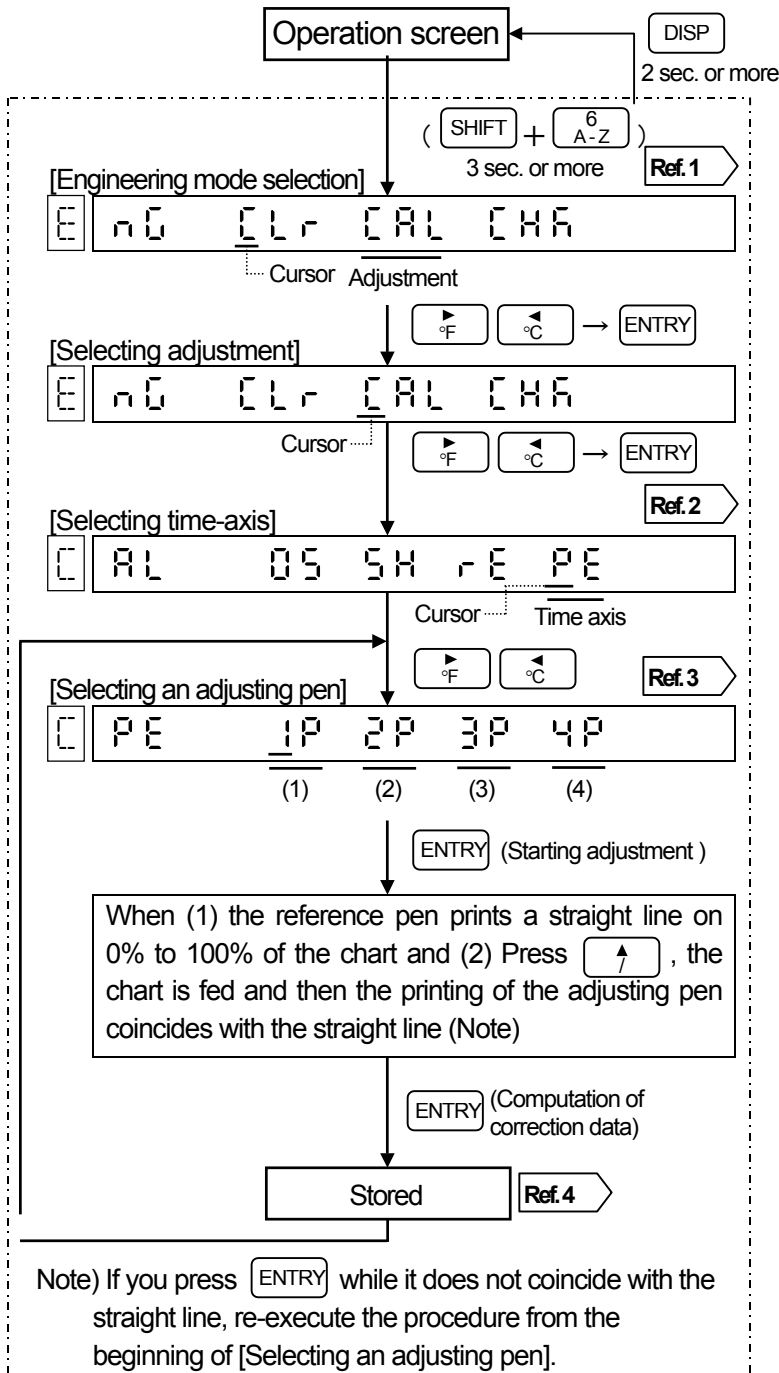

Adjustment procedure

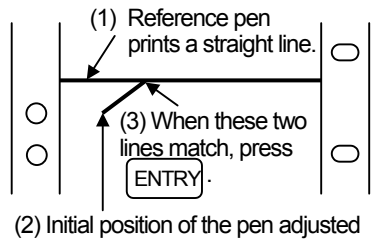

Other pens than the pen being adjusted

Pens stand by at 0% position of scale.

Reference 1 Engineering mode types

CLr: Memory clear
 CAL: Adjustment
 CHk: Hardware check

Reference 2 Adjustment types

OS: Measured value adjustment
 SH: Shift programming for measured value
 rE: Printing position adjustment
 PE: Time-axis adjustment for pens

Reference 3 Adjusting pen selection

Display	Reference pen	Pen to be adjusted
(1) 1 P	Plotter pen	1st pen
(2) 2 P	1st pen	2nd pen
(3) 3 P	1st pen	3rd pen
(4) 4 P	1st pen	4th pen

Reference 3 Storing

Store the computed correction data into memory.

19. HARDWARE CHECK 19.1 ROM Version Check

Hardware check

Hardware check comprises the following seven items. Items (5) to (7) only apply to corresponding options added.

Check items	Details	Ref. page
(1) ROM version check	Checking of versions for ROM and linearization	Sec. 19.1
(2) Printer test	Checking of printing with the cartridge pens and the plotter pen	Sec. 19.2
(3) Display test	Checking of LCD on the display	Sec. 19.3
(4) Measuring input check	Checking of real data (A/D converted value) of each channel	Sec. 19.4
(5) Alarm output check	Output of on or off signal from terminals	Sec. 19.5
(6) Remote contacts input check	Checking of input condition (open or short) at terminals	Sec. 19.6
(7) Communications interface check	Checking of communications function	Sec. 19.7

1 Check Flow Chart

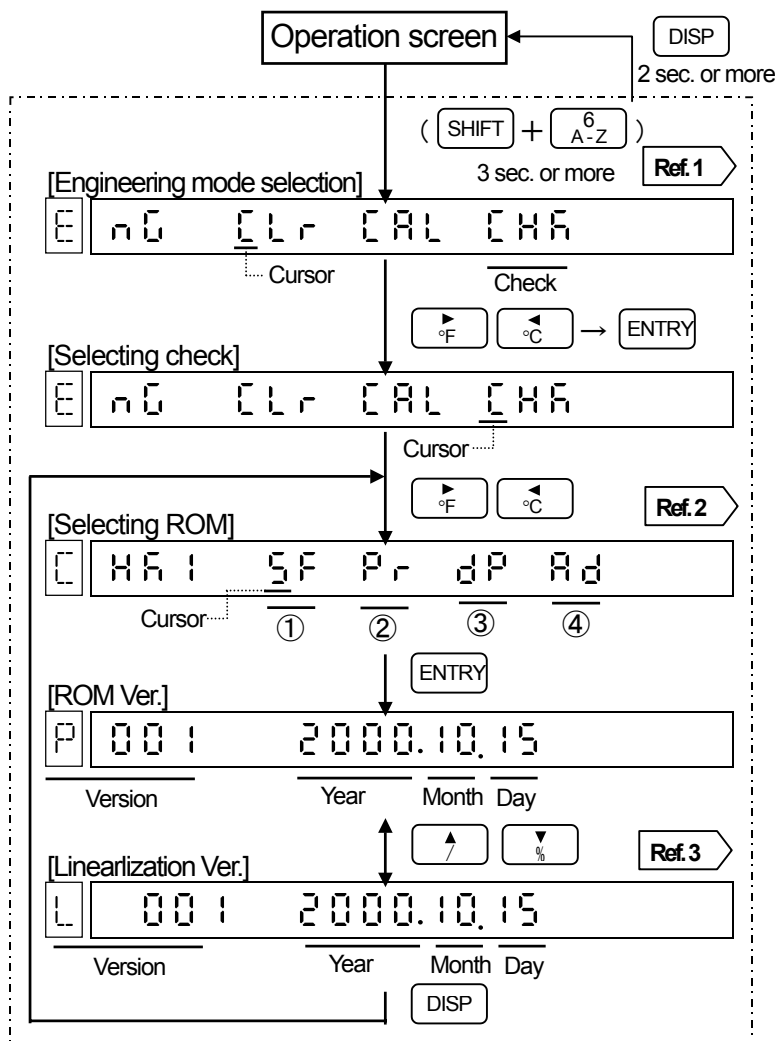

Reference 1 Engineering mode types

- [C] : Memory clear
- [A] : Adjustment
- [H] : Hardware check

Reference 2 Types of check 1

- (1) S F : ROM version check
- (2) P r : Printer check
- (3) d P : Display check
- (4) i n : Measuring input check

Reference 3 ROM and linearization check

Press **↑** or **↓** to check the versions of ROM or linearization.

19. HARDWARE CHECK 19.2 Printer Check

This is for checking of trace printing with the cartridge pens and digital data printing with the plotter pen.

1 Example of Printing Check – When the time-axis synchronization (POC) is “off” in 3-pen type

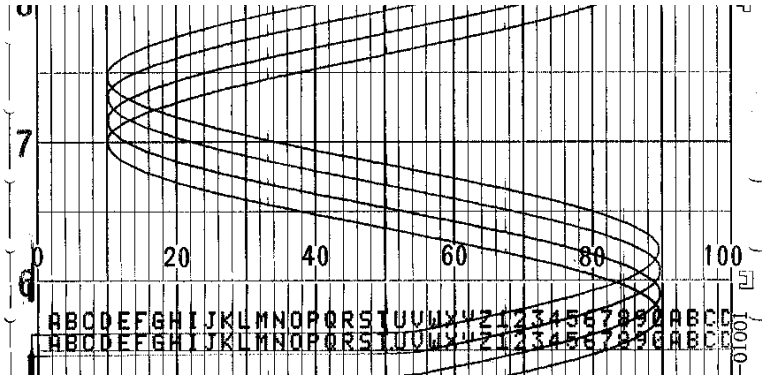

2 Check Flow Chart

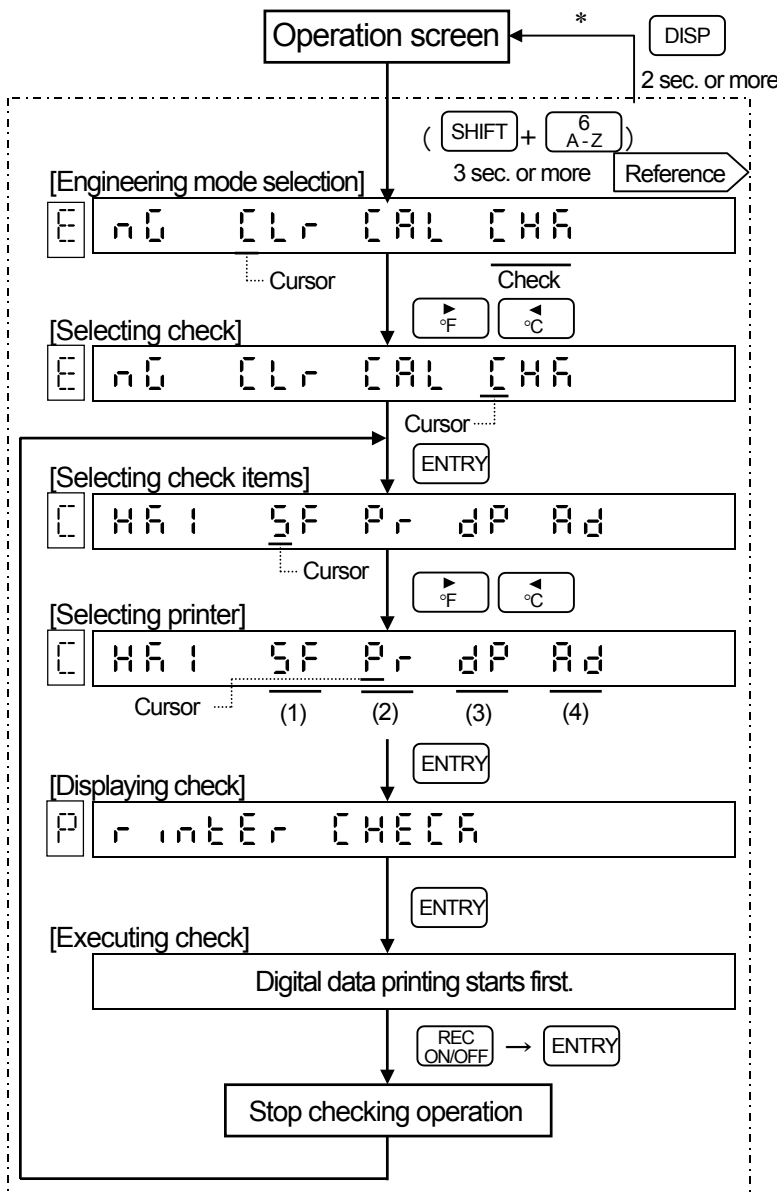

Check printing details

- Digital data printing (Plotter pen)**
Two lines are printed. The number of characters per line is 40 with AL and 72 with the AH (repetition of A to Z, 1 to 9 and 0).
 - Trace printing (Cartridge pens)**
Each pen prints a sine curve.
- (Note)**
Even when the time-axis synchronization is on, printing is executed in condition of the time-axis synchronization “off” during printing check.

* [DISP] is not accepted during printing check.

Cancellation of printing check

For cancellation of printing check, press [REC ON/OFF] and then press [ENTRY]. By pressing [DISP] for 2 seconds or more, the screen returns to the operation screen, but the printing disables. For changing the printing to enable, press [REC ON/OFF] and then press [ENTRY] again.

Reference Types of engineering mode and check 1

See Reference 1 and Reference 2 in section 19.1.

19. HARDWARE CHECK 19.3 Display Check

This is for checking of 16- or 7-segment LCD, status lamps and bargraphs.

1 Display (Note) The following is for AL3000. It is same for AH3000.

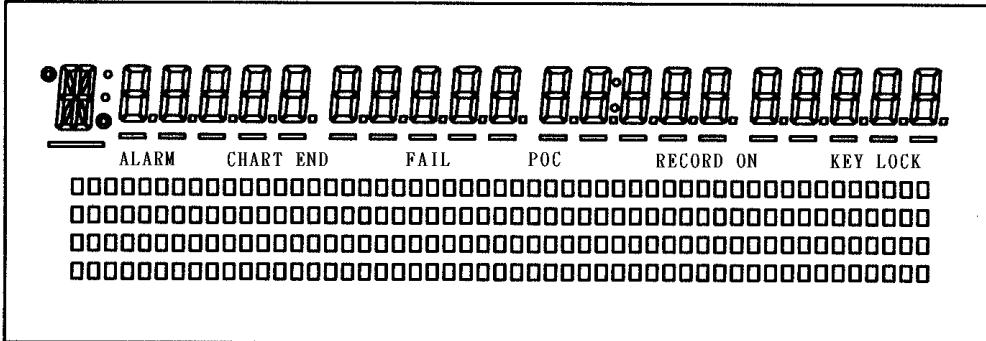

2 Check Flow Chart

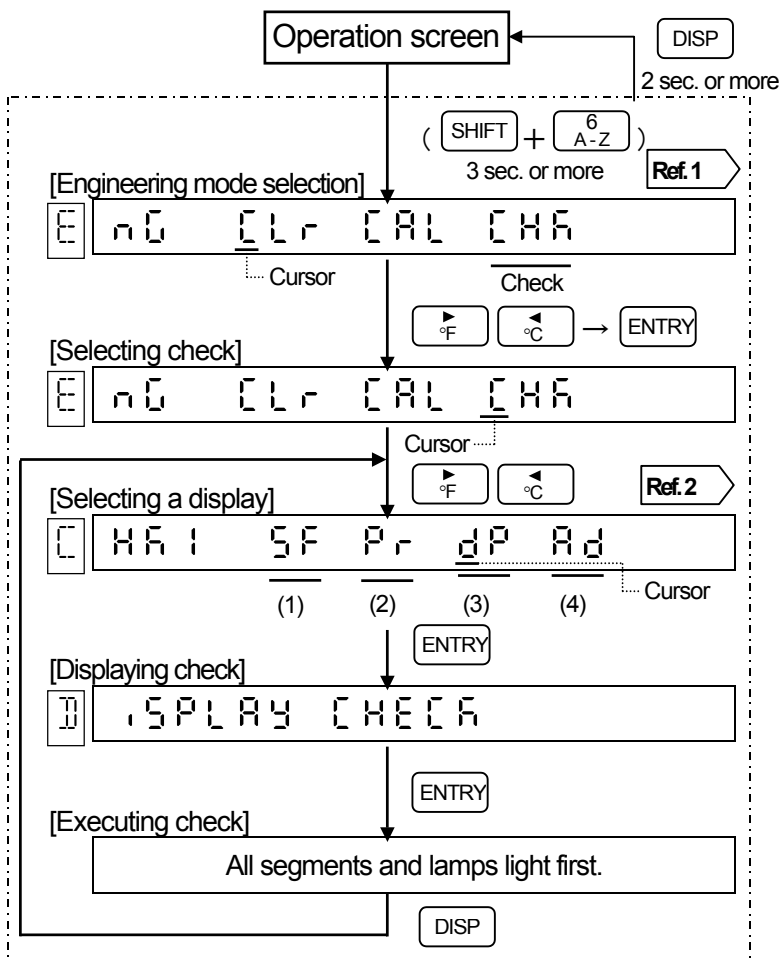

- Order of check lighting**
- (1) All segments and lamps light.
 - (2) 16-segment LCD and underbar
 - (3) 7-segment LCD and underbars (From left to right)
 - (4) Programming lamp, memory colon and status lamps (all)
 - (5) Bargraph on the upper row (5-segment at a time, from left to right)
 - (6) Bargraph on the second row (Same as the upper row) → On the third row → On the fourth row
 - (7) All segments and lamps light out.

Cancellation of display check
For cancellation of display check, press **DISP** for 2 seconds or more.. The screen returns to the operation screen.

- Reference 1 Engineering mode types**
- [CLR] : Memory clear
 - [CAL] : Adjustment
 - [CHA] : Hardware check

- Reference 2 Types of check 1**
- (1) [nG] : ROM version check
 - (2) [Pr] : Printer check
 - (3) [dP] : Display check
 - (4) [n] : Measuring input check

19. HARDWARE CHECK 19.4 Measuring Input Check

The measuring input can be checked by counts after A/D conversion.

Check Flow Chart

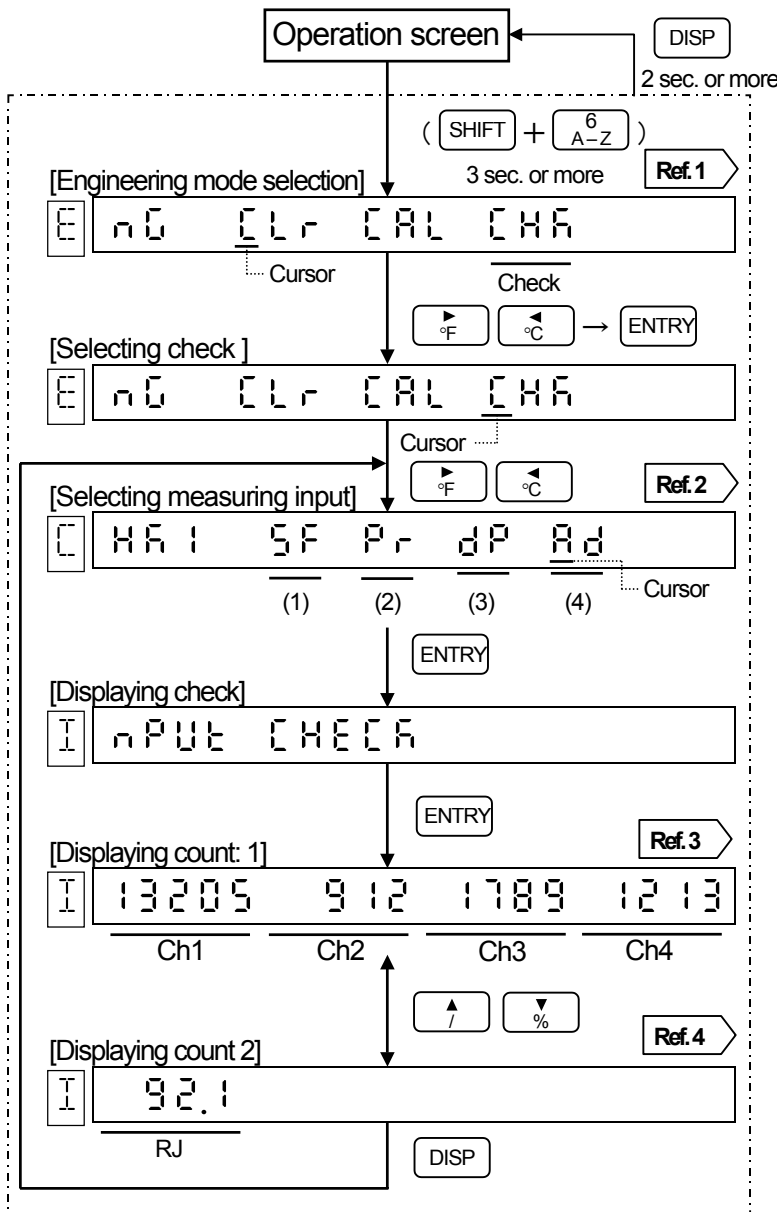

Reference 1 Engineering mode types

CLR: Memory clear
CAL: Adjustment
CHA: Hardware check

Reference 2 Types of check 1

- (1) ROM version check
- (2) Printer check
- (3) Display check
- (4) Measuring input check

Reference 3 Count 1 display

CH1 to CH4 show the counts after A/D conversion of inputs to channels 1 to 4.

For AH3000, the RJ (reference junction compensation) count is displayed next to CH4.

Reference 4 Count 2 display

RJ is the counts after A/D conversion of the reference junction compensation (RJ). AH3000 has no Count 2 display as RJ is displayed in Count 1 display. RJ is displayed only when there is a channel, of which RJ is programmed to "1: enable" in the range programming. When all channels are programmed to "0: disable", (- - -) is displayed.

19. HARDWARE CHECK 19.5 Alarm Output Check

This check is only available for the alarm output (option). It checks the relay drive circuits and relays by outputting the shorted (on) or open (off) signals at the specified alarm output terminals (relay Nos.).

Check Flow Chart

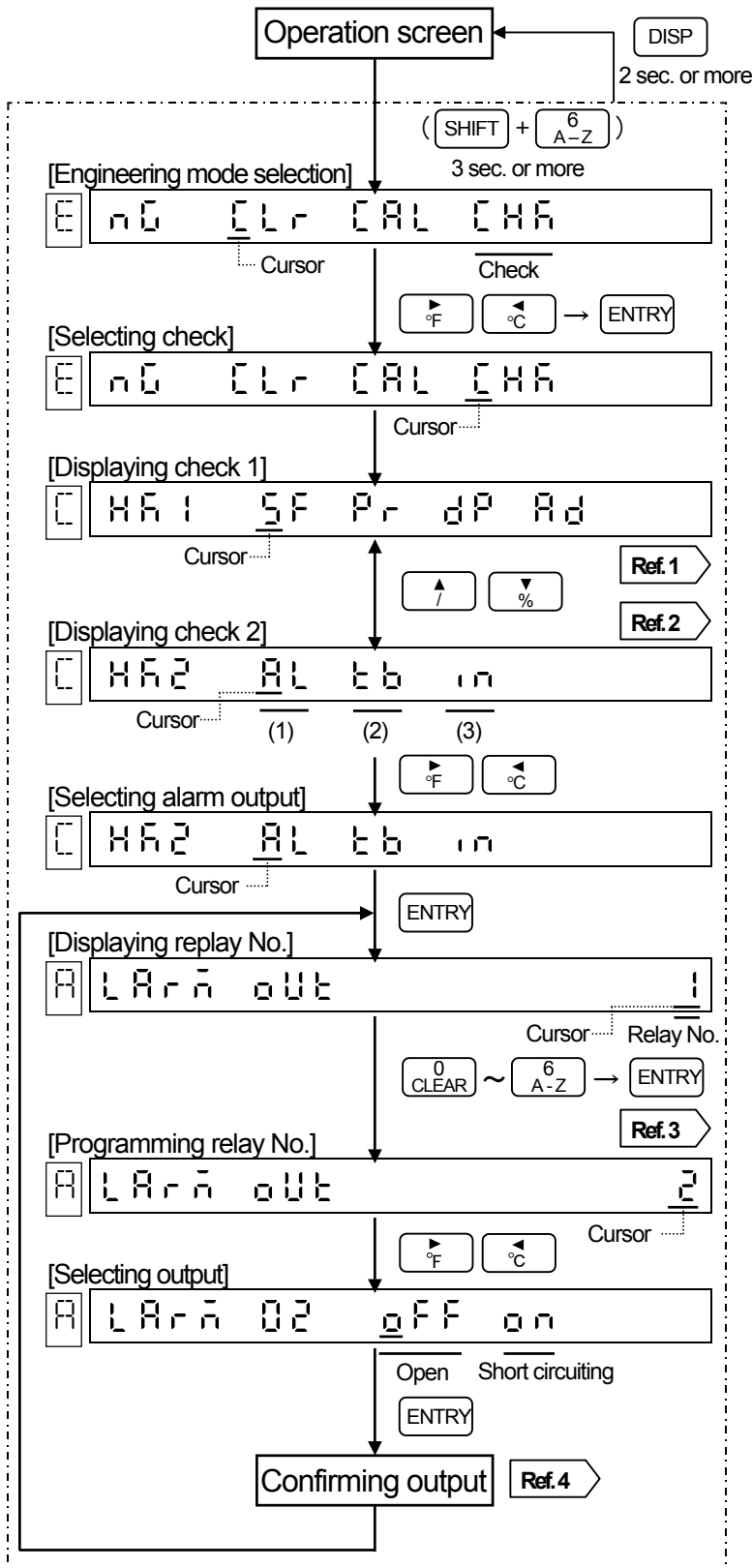

Relay No. for alarm output terminals

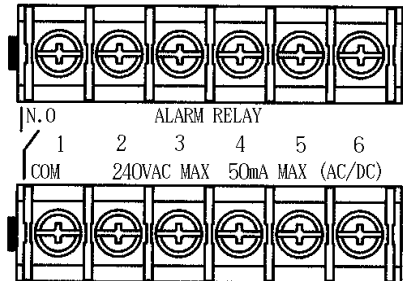

* N.C terminals are provided for the mechanical relay "c" contact output.

Resistance values between terminals

Output	Output condition	N.O - COM
MOS relay	Off	10MΩ or more
	On	50Ω or less
Mechanical relay (Common for "a" and "c" contacts)	Off	10MΩ or more
	On	0.1Ω or less

Reference 1 Check 1 and 2 switching

Press or to switch Check 1 and 2.

Reference 2 Types of check 2

- (1) : Alarm output check
- (2) : Remote contacts input check
- (3) : Communications interface check

Reference 3 Programming relay No.

The programming range of relay Nos. are 1 to 6 for AL and 01 to 12 for AH.

Reference 4 Output

The selection of output (on or off) is effective at the moment is pressed. The previous output status is kept until then.

19. HARDWARE CHECK 19.6 Remote Contacts Input Check

This check is only available for the remote contacts (option). It checks the input signals (shorted or open) at the remote contacts terminals.

Check Flow Chart

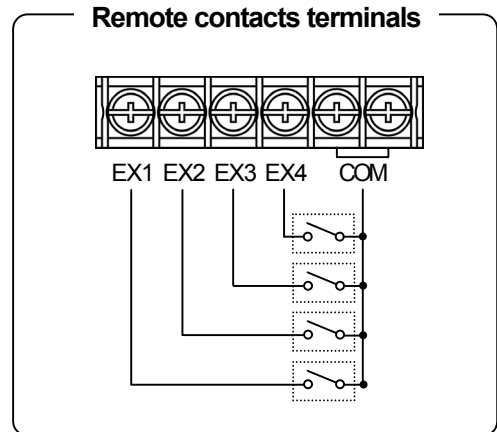
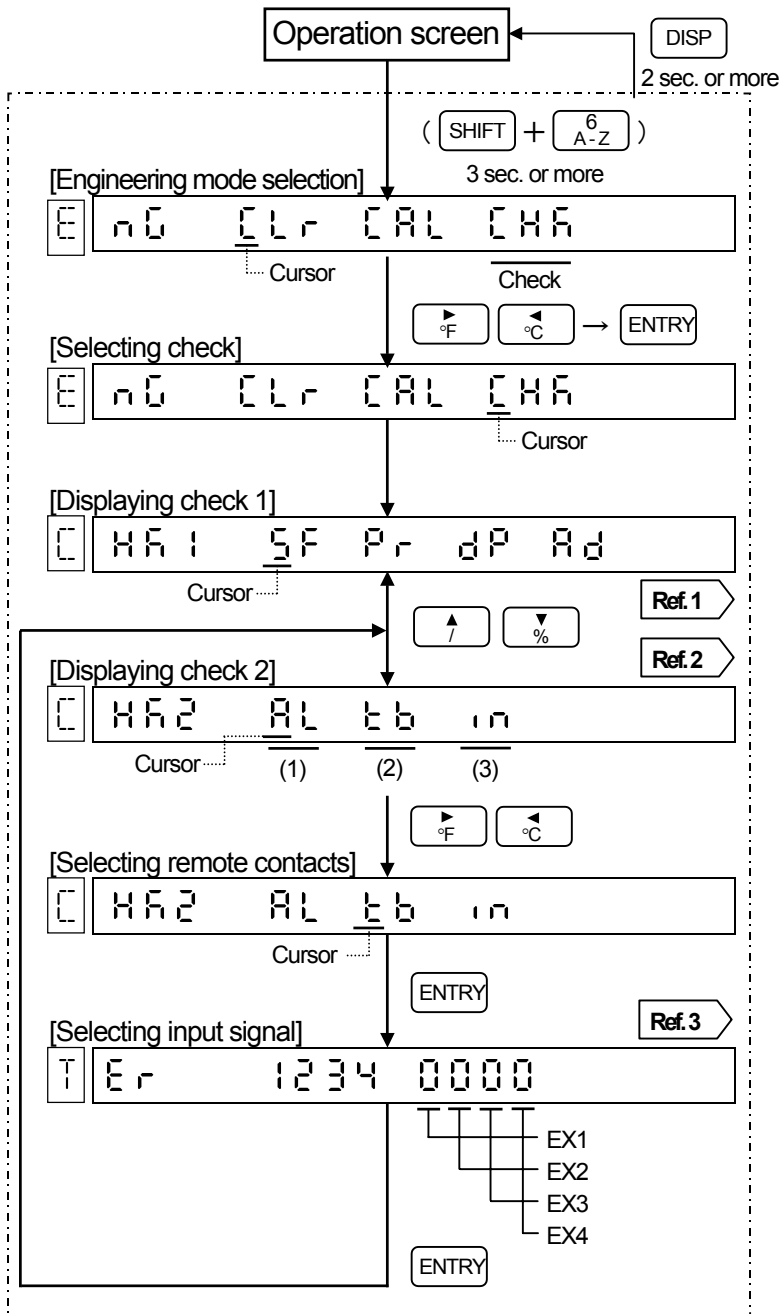

Remote contacts signals and functions

Eleven kinds of operations are available by the remote contacts signals. The operation allocated to each terminal (EX1 to EX4) can be checked. ⇒ See Section 13.2.

Reference 1 Check 1 and 2 switching

Press **↑** or **↓** to switch Check 1 and 2.

Reference 2 Types of check 2

(1) AL: Alarm output check
 (2) tb: Remote contacts input check
 (3) in: Communications interface check

Reference 3 Input signal

The input signals at EX1 to EX4 are:
 0: Open 1: Shorted

19. HARDWARE CHECK | 19.7 Communications IF Check

This check is only available for the communications interface (option). It checks the communications function by displaying the signal received after transmitting it.

1 Connections

Except for RS-485, short the transmission and reception terminals.

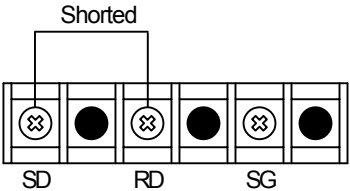
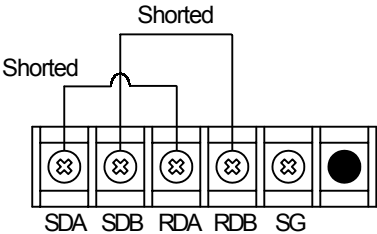
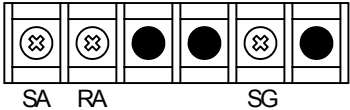
RS-232C	RS-422A	RS-485
 <p>Shorted</p> <p>SD RD SG</p>	 <p>Shorted</p> <p>Shorted</p> <p>SDA SDB RDA RDB SG</p>	 <p>SA RA SG</p>
<p>Short SD and RD terminals.</p>	<p>Short SDA and RDA terminals. Short SDB and RDB terminals.</p>	<p>Open circuit. (No need to short.)</p>

19. HARDWARE CHECK 19.7 Communications IF Check

2 Check Flow Chart

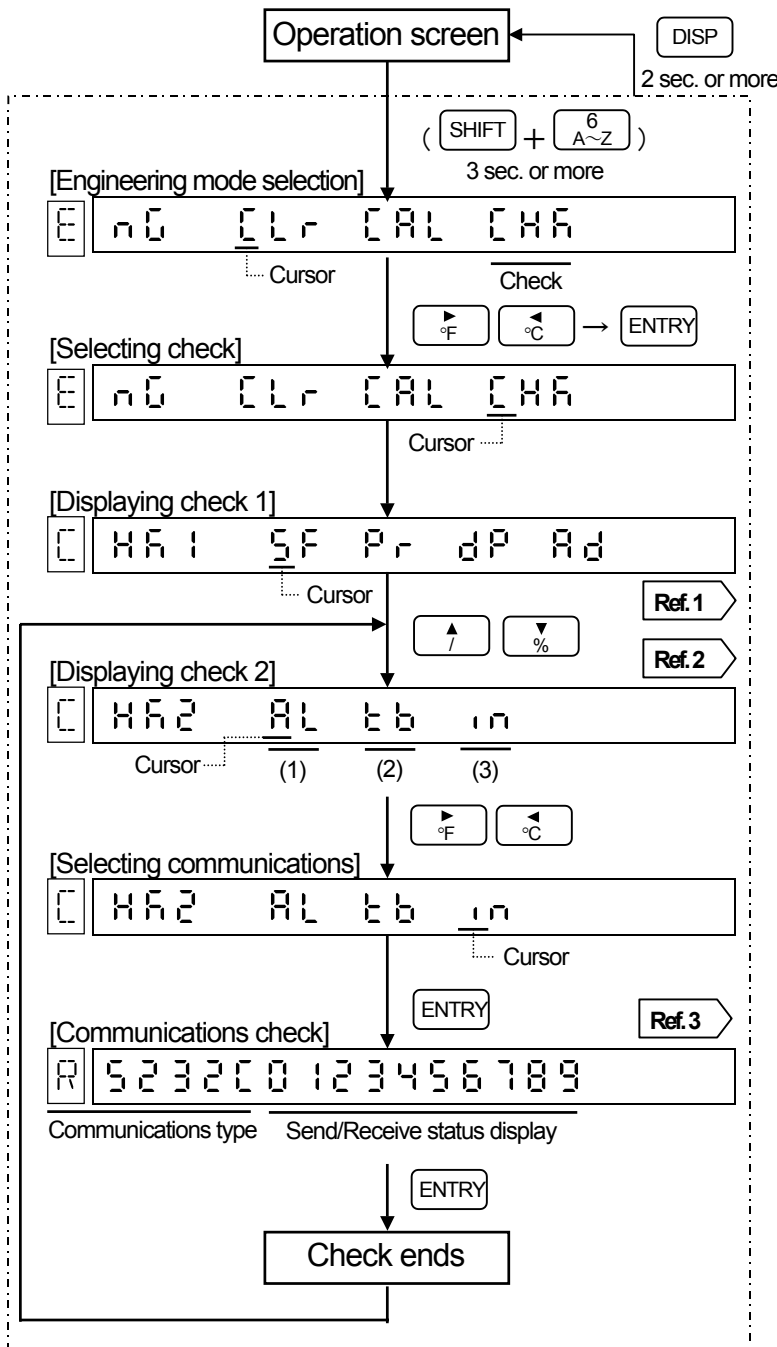

Reference 1 Check 1 and 2 switching

Press or to switch Check 1 and 2.

Reference 2 Types of check 2

- (1) AL: Alarm output check
- (2) bb: Remote contacts input check
- (3) in: Communications interface check

Reference 3 Communications check

1. Communications type
Communications type installed is displayed.

- RS232C

- RS422A

- RS485

2. Communications status display

- Normal condition:

Displays one digit by one digit as 0 → 1 → 2 ...9, and after 9, repeat from 0 again.

- Abnormal condition:

One of 0 to 9 blinks. In this case, communications circuit is abnormal.

20. MEMORY CLEAR

This is for initializing parameters and correction data to the default values.

1 Initialization items

Items	Clear function details and cautions
Parameters	Initializes all parameters excluding [time] to the default values. Refer to Section 7.3 (List of programming items) for the default values.
Correction data	Initializes all correction data to the default values.
Clock	The time is preprogrammed to Japanese time at shipment. When initializing the time, it becomes 00:00 hours on January 1, 2000. If the operation screen is not shown due to a failure of the LSI for time, clear the programmed time.

2 Operation Flow Chart

<Example> Initializing parameters

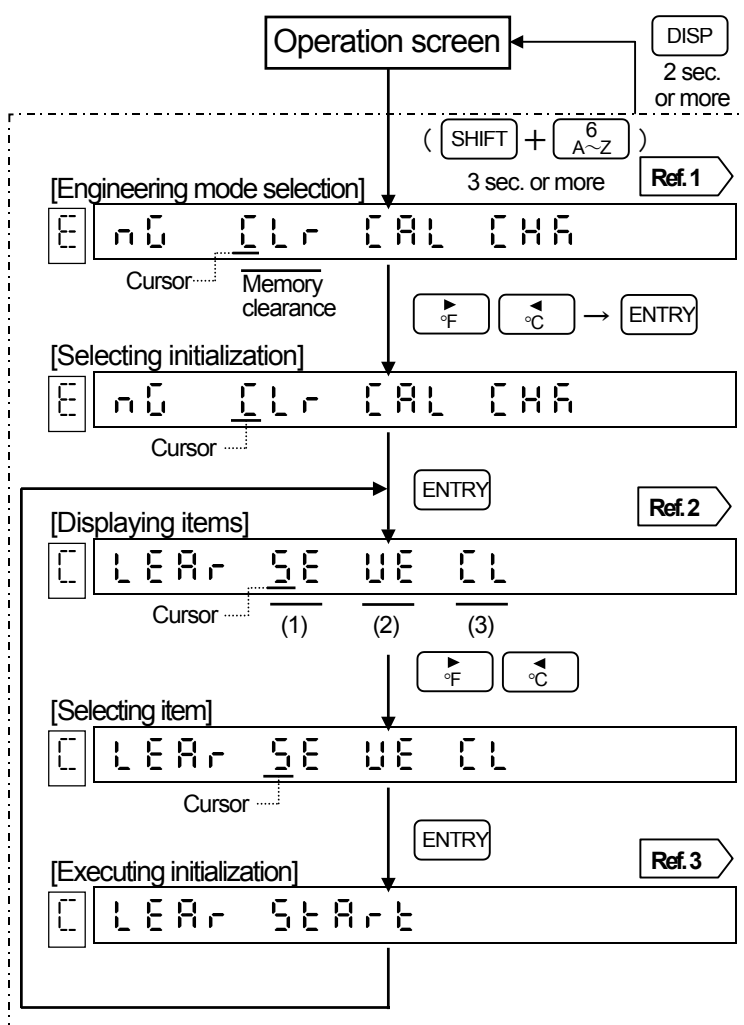

Reference 1 Engineering mode types

- CLR: Memory clear
- CAL: Adjustment
- CHA: Hardware check

Reference 2 Initialization items

- (1) SE: Parameters
- (2) UE: Correction data
- (3) CL: Clock

Reference 3 Initialization

Press ENTRY to initialize the selected item. After initialization, the screen returns to the [Displaying items] screen.

21. MAINTENANCE

21.1 Daily Inspection

Check the residual quantity of chart paper, displaying/printing conditions, etc. on a daily basis in order to use your recorder under good conditions.

1 Consumable parts check

Check items	Checking methods																						
1. Residual quantity of chart	<p>Check the residual quantity of chart. When the residual quantity becomes less, a message "Prepare a new chart" or "New Paper Required" appears with red ink on the left of the chart paper.</p> <ul style="list-style-type: none"> • Loading chart paper → See Section 5.1. • Ordering chart paper → See Section 1.2. <p>Reference → Continuous printing days of chart paper</p> <table border="1" style="width: 100%; border-collapse: collapse; margin: 10px 0;"> <thead> <tr> <th colspan="3">AL3000</th> <th colspan="2">AH3000</th> </tr> <tr> <th rowspan="2">Chart speed</th> <th colspan="2">Continuous printing days</th> <th rowspan="2">Chart speed</th> <th rowspan="2">Continuous printing days</th> </tr> <tr> <th>Standard</th> <th>16 m</th> </tr> </thead> <tbody> <tr> <td>10 mm/h</td> <td>Approx. 40 days</td> <td>Approx. 60 days</td> <td>25 mm/h</td> <td>Approx. 30 days</td> </tr> <tr> <td>20 mm/h</td> <td>Approx. 20 days</td> <td>Approx. 30 days</td> <td>50 mm/h</td> <td>Approx. 15 days</td> </tr> </tbody> </table>	AL3000			AH3000		Chart speed	Continuous printing days		Chart speed	Continuous printing days	Standard	16 m	10 mm/h	Approx. 40 days	Approx. 60 days	25 mm/h	Approx. 30 days	20 mm/h	Approx. 20 days	Approx. 30 days	50 mm/h	Approx. 15 days
AL3000			AH3000																				
Chart speed	Continuous printing days		Chart speed	Continuous printing days																			
	Standard	16 m																					
10 mm/h	Approx. 40 days	Approx. 60 days	25 mm/h	Approx. 30 days																			
20 mm/h	Approx. 20 days	Approx. 30 days	50 mm/h	Approx. 15 days																			
2. Plotter pen	If the text on the digital data printing becomes unclear or pale, replace the plotter pen with a new one. See Section 5.2.																						
3. Cartridge pen	If the line on the trace printing becomes unclear or pale, replace the cartridge pen with a new one. See section 5.2.																						

2 Operation check

Check items	Checking details
1) Printing conditions	(1) Chart feeding condition Check that there is no paper jam or dislocation from the sprocket. (2) Text and trend line printing condition Check that no disorder or abnormal condition is found in the text and trend line printing.
2) Display conditions	Check that no abnormalities are found in the displays of measured values, status and bar-graph.
3) Others	(1) Check that the measured values are normal. (2) Check if any noise or strange odors are generated.

21. MAINTENANCE

21.2 Cleaning and Lubrication

Clean the main shaft of each pen once a year in order to maintain a satisfactory printing performance.

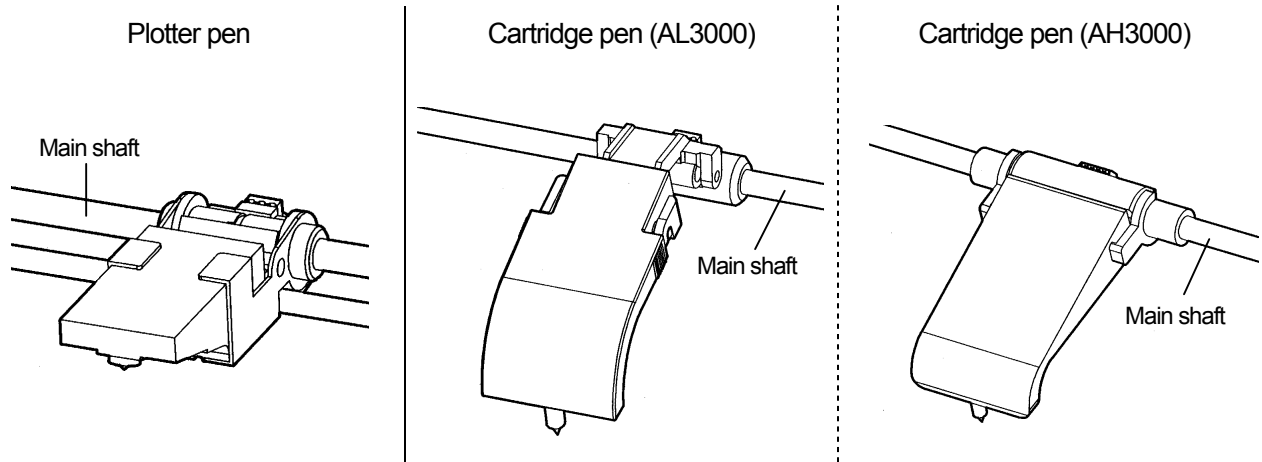

1 Main Shaft of Plotter Pen

- (1) Turn off printing. Pull out the chart cassette and open the display section.
- (2) Wipe off dirt from the main shaft with a cotton bud or similar tool. (Dirt can be wiped off more easily with a cotton bud soaked in alcohol.)
- (3) Apply one or two drops of the provided lubricating oil to the main shaft.

2 Main Shaft of Cartridge Pen

- (1) Turn off printing. Pull out the chart cassette and open the display section.
- (2) Wipe off dirt from the main shaft with a cotton bud or similar tool.
- (3) Apply one or two drops of the provided lubricating oil to the main shaft.

Remarks

Caution on cleaning and lubrication

- (1) Do not move the plotter pen or cartridge pen by hand.
- (2) Use the provided lubricating oil. Do not use any other oil.

3 Cleaning the Door

The door is made of plastic*. Clean it with a dry soft cloth or with a soft cloth moistened with lukewarm water or a neutral detergent.

* Aluminum die-cast door is available as an option. (AL3000)



Caution Do not use any chemicals

Do not use thinner, benzene or other chemicals that may damage the plastic components. These may cause deformation or breakage to the door.

21. MAINTENANCE

21.3 Measured Values Check

It is recommended to check measured values once a year for maintaining the measuring and printing accuracy.

1 Channels to be checked

Check the measured value for each channel. Different errors may occur for different channels even in the same range.

Remarks **Totalization channel**

To check a channel for which a math-function or totalization (optional) has been programmed, program the math expression to “ $\square \square \square$ ” before starting the checking.

Reference conditions

Items	Reference conditions
Ambient temperature	$23 \pm 2^{\circ}\text{C}$
Ambient humidity	$55 \pm 10\% \text{RH}$
Power voltage	$100 \text{ V AC} \pm 1\%$
Power supply frequency	$50 \text{ or } 60 \text{ Hz} \pm 0.5 \text{ Hz}$

(Note) Add $\pm 0.01\%$ per 1°C for a case other than $23 \pm 2^{\circ}\text{C}$.

2 Preparation

1) Preparation of tools

Tools	Input types			Remarks
	DC voltage	Thermo-couple	Resistance thermometer	
DC standard voltage/current generator	○	○		Accuracy: Should be better than $\pm 0.05\%$.
Reference junction compensator		○		$0^{\circ}\text{C} \pm 0.2^{\circ}\text{C}$
Thermocouple for test		○		Same type of thermocouple as input type
Standard variable resistor			○	Accuracy: Should be better than $\pm 0.05\%$.
3-core copper wire			○	Three copper wires shall have the same resistance values.

2) Connection

Connections depend upon the input types. See the next page.

3) Before starting adjustments

- (1) Mount the terminal board cover and turn on the power supply.
- (2) Before starting adjustments, warm up your recorder for at least 30 minutes until it becomes stable. (It is recommended to warm up for at least one hour if possible.)

Remarks **Checking**

Check and adjustments of the measured values need meticulous work in addition to the standard tools and reference conditions.

If you need checks or adjustments of the measured values, please consult your nearest CHINO's agent.

21. MAINTENANCE 21.3 Measured Values Check

3 Connections

Connections depend upon the input types. Connect both standard and other tools to the measuring input terminals to be adjusted.

 **Caution** Turn off the power source before starting connections

In order to prevent electric shock, turn off the power source before starting connections.

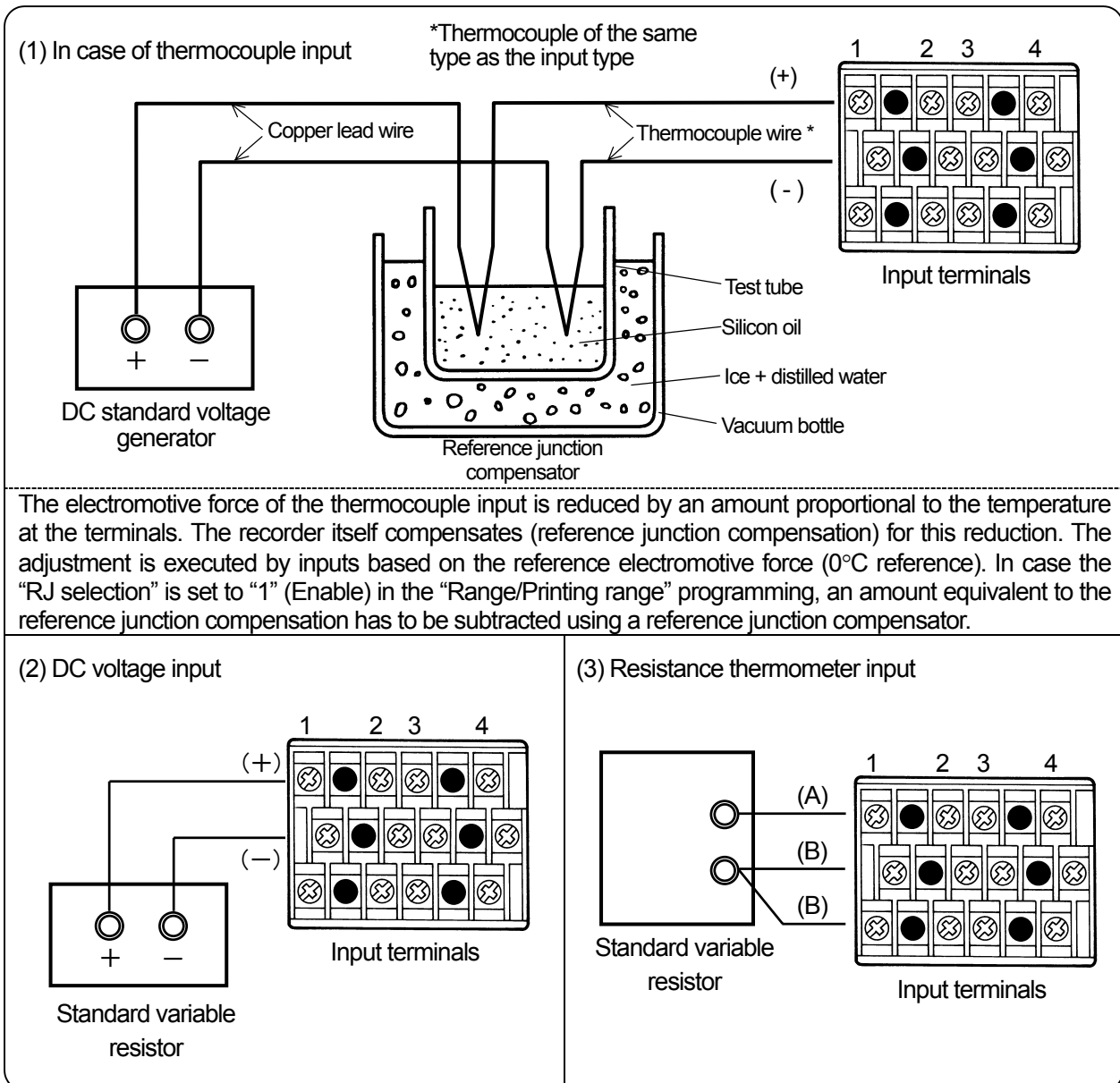

4 Checking Method

Input the printing range (T) of 0%, 50% and 100% from a standard tool and obtain an error (e) by reading the measured values (M).

Error computation

$$e (\%) = \frac{M - T}{T} \times 100$$

21. MAINTENANCE

21.4 Troubleshooting

Troubleshooting methods are shown classified by symptoms. Read the item that corresponds to the symptom.

Caution Repair and modifications

Never repair or modify the instrument by replacing assembled component units or parts, otherwise correct repair or modifications cannot be executed and also electric shock or damage of your recorder may occur.

1 Not Working

Check	Causes and remedial measures
1) Check if power is supplied to the power terminals.	Turn on the external power supply source.
2) Check if the power supply is as specified.	Supply the specified power (100 to 240V AC and 50/60 Hz).
3) Check if the connections to the power terminals are correct.	Connect the cable to the power terminals (L, N) correctly.
4) Try turning off or on the external power supply source.	
5) Initialize the parameters and check if your recorder recovers to normal conditions. See Section 20. (Caution) All parameters become the default values. Program them again.	

2 Measured Value Abnormal

Symptoms	Causes and remedial measures
1) Measured values are unstable.	<ul style="list-style-type: none"> • Check if the measuring terminals are loose. • Check if the input signal is unstable. • Check if the thermocouple is connected with another instrument in parallel and the burnout function is programmed to [Enable].
2) Check if the measured value is displayed as shown below. <div style="display: flex; justify-content: space-around; align-items: center;"> <div style="border: 1px solid black; padding: 2px 10px;">-----</div> <div style="border: 1px solid black; padding: 2px 10px;">burn</div> </div>	<ul style="list-style-type: none"> • Check if the input terminals are connected correctly. • Check if the input terminals are loose. • Check if the input signal wires are disconnected. • Check if the input signal exceeds the measuring range.
3) An error occurs.	<ul style="list-style-type: none"> • Check if the selection of °C/°F computation is correct. • Check if the input signal is correct. • Check if an extension wire is connected to the input terminal. (Thermocouple input type only) • Check the scale and adjust the measured values if any error is detected. (See Section 18.1.)
4) Influences by ambient temperature (Thermocouple input type only)	<ul style="list-style-type: none"> • Check if the RJ selection is 0 (disable) in [Range/Printing range] programming. (This is negligible if reference junction compensation is executed externally.) • Check if the terminal cover is mounted.

21. MAINTENANCE 21.4 Troubleshooting

3 Display Abnormal

Symptoms	Causes and remedial measures
1) Measured value blinks.	Measured value of the channel in which an alarm activates. See Section 10.3.
2) Measured value is blank.	No measured value is displayed for the skipped channel.
3) Year, month, day, hour and minute are displayed.	This is one of the operation screens (Clock display). See Section 6.4.
4) "F1" is displayed at the left end.	This is one of the operation screens (Alarm activation screen). See Section 6.4.

4 Printing Abnormal

Symptom	Causes and remedial measures
1) No printing is executed.	<ul style="list-style-type: none"> • Check if the printer is turned off. See Section 6.2. • Check if the cassette ribbon is mounted normally.
2) Digital printing is not executed.	All digital printings are not executed if the chart speed is programmed to be faster than 150mm/h. See Section 10.2.
3) Printing color is pale.	Replace the cartridge pen or the plotter pen.
4) Chart paper feed is abnormal.	<ul style="list-style-type: none"> • Check if the chart paper is unlatched from the sprocket. • Check if the chart paper cassette is securely inserted into the internal unit. • Check if the chart paper has been shuffled before loading it.

5 Other Troubles

Symptoms	Causes and remedial measures
1) Keys are not acceptable.	Keys are locked. Unlock them. See Section 11.12.
2) Parameters cannot be changed.	
3) Parameters remain unchanged after changing them.	To store parameters to be programmed for each channel, press SHIFT and SHIFT simultaneously. If not, parameters are not stored into memory. See Section 8.2 and other sections for programming.

Request

If the above troubleshooting cannot solve your problem, certain parts may be defective. Check the following items and contact your CHINO's sales agent.

(1) Model (2) Serial No. (3) Details of trouble (4) Other symptoms found

21. MAINTENANCE

21.5 Recommended Parts Replacement Intervals

It is recommended to replace parts periodically as a preventive measure to enable the use of your recorder under ideal conditions over long periods of time.

⚠ Caution Replacement of parts

Do not replace any parts other than consumable chart paper and pens, otherwise your recorder cannot be recovered correctly and a dangerous accident may occur. Consult CHINO's sales agent for replacing parts.

1 Operation conditions

The recommended parts replacement intervals apply when your recorder is used under the following conditions. The replacement intervals could be shortened if the ambient conditions are worse than the followings.

Items	Conditions
Temperature	20 to 25°C
Humidity	20 to 80% RH
Operation hours	8 hours/day
Corrosive gas	Shall be free of corrosive gases

Items	Conditions
Others	(1) A place free from dust, moisture or soot (2) A place free from vibrations or shock. (3) A place where no unfavorable conditions are to be expected.

2 Recommended intervals of parts replacement

1) Parts to be mounted (Consumable parts)

Part names		Recommended intervals	Remarks
Chart paper (AL3000)	10 m (Standard)	20 days	In case of continuous use with a chart speed of 20 mm/h
	16 m (Option)	30 days	
Chart paper (AH3000)		30 days	In case of continuous use with a chart speed of 25 mm/h
Cartridge pen		2km	Could be shorter than 2 km depending on chart paper speed, pen speed and ambient temperature/humidity.
Plotter pen		100,000 characters	Could be less than 100,000 characters depending on chart paper speed and ambient temperature/humidity.

2) Component parts

Part names		Recommended intervals	Remarks
Mechanical components	Pen servo (for cartridge pen)	4 to 6 years	
	Pen servo (for plotter pen)	4 to 6 years	
	Chart drive mechanism	6 to 8 years	
Electrical component	Motor (for chart paper)	4 to 6 years	
	Motor (for plotter pen)	4 to 6 years	
	Motor (for cartridge pen)	4 to 6 years	
	Power supply unit	5 years	Under an ambient temperature of 25°C
	Display unit	4 to 6 years	
	Sheet switch (key)	4 to 6 years	
	Mechanical relay for alarm output	70,000 times	Resistive load (rated contact capacity or less)
		20,000 times	Inductive load (rated contact capacity or less)
EEPROM		7 years	Able to re-write about 100,000 times or less
Lithium battery		7 years	

22. SPECIFICATIONS

1 Input Specifications

Number of measuring points: 1, 2, 3 and 4 points

Input signals: DC voltage (mV) ... ± 13.8 , ± 27.6 , ± 69.0 , ± 200
 ± 500

DC voltage (V) ... ± 2 , ± 5 , ± 10 , ± 20 , ± 50 (Built-in voltage divider for ± 5 V or more)

DC current ... Available by adding shunt resistor (option)

Thermocouple ... B, R, S, K, E, J, T, N, NiMo-Ni, CR-AuFe, PtRh40-PtRh20, WRe5-WRe26, W-WRe26, Platinel II, U, L

Resistance thermometer ... Pt100 (1), Pt100 (2), JPt100, Pt50, Pt-Co

Range: Program range number and printing range for each channel with key operation. (See Section 8.2 for range No. list)

Scale: Program minimum and maximum values with key operation.

Programming range ... -9999 to 99999

Decimal point ... Program arbitrary

Measuring range: Refer to the list of range No. in Section 8-2.

Minimum printing range: Refer to the following table

DC voltage	1/5 or higher than the measuring range.	
Thermocouple	2/5 or higher than the measuring range when converted into electromotive force. (In the case of range Nos. with minus measuring ranges, a temperature of 0°C or higher is specified as the lower-limit measuring value.)	
Resistance thermometer	Pt100	100°C span or more
	Pt50	200°C span or more

Accuracy rating: Refer to item **6** (at reference operating condition).

Temperature drift: $\pm 0.01\%$ full scale/°C (converted into reference range)

Measuring cycle: About 100 msec (CH1 to CH4)

Reference junction compensation: Inside (enable) or external (disable) is selectable.

Reference junction compensation accuracy:

K, E, J, T, N and Platinel II ... $\pm 0.5^\circ\text{C}$ or less

Other than the above* ... $\pm 0.1^\circ\text{C}$ or less

*Except PtRh40-PtRh20

Input resolution: Approx. 1/56000 (converted into reference range)

Burnout: Effective input... Thermocouple, resistance thermometer

Programming range ... Selection from up-scale, down-scale or disable for each channel

Allowable signal source resistance:

DC voltage inputs, thermocouple inputs ... $1\text{k}\Omega$ or less*

Resistance thermometer inputs ... 10Ω or less

* Without burnout

Input resistance: Thermocouple input ... About $8\text{M}\Omega$

DC voltage inputs (range of ± 2 V or less) ... About $8\text{M}\Omega$

DC voltage inputs (range of ± 5 V or less) ... About $1\text{M}\Omega$

Maximum input voltage

DC voltage inputs, thermocouple	± 10 V DC or less (range of ± 2 V or less) ± 60 V DC or less (range of ± 5 V or less)
Resistance thermometer	± 6 V DC or less

Input correction: Shift programming for each channel

Input filter: Program primary delay filter 1 to 10 sec. and "0" (none) for each channel.

Maximum common mode voltage: 30VAC

Common mode rejection ratio: 140 dB or more (50/60 Hz)

Series mode rejection ratio: 50 dB or more (50/60 Hz)

Terminal board: Detachable and removable for wiring

2 Printing

Printing accuracy: Measuring accuracy + $\pm 0.3\%$ of printing range (under the reference operation condition)

Printing dead and: 0.2% of printing range

Printing system:

Trace printing... Disposable cartridge pen

Digital data printing ... Plotter pen

Step response: AL3000 ... 1 sec. or less (90% response)

AH3000 ... 1.5 sec. or less (90% response)

Print color: Trace printing ... 1st pen (Red), 2nd pen (Green), 3rd pen (Blue), 4th pen (Brown)

Digital data printing ... Purple

<<Digital printing>>

- ① Periodic data printing : Printing of time, channel No., measured values and engineering unit with programmed interval
- ② Digital data printing : Printing of time, channel No., measured values and engineering unit with trace printing on demand
- ③ Year, Month, day, time, time line : Printing of year, month, day and time when turning on the power. Printing time line and time every on the hour. Printing year, month and day at 00:00 and every specific interval
- ④ Channel No., scale, tag : Printing of scale, channel No. and tag (only if they are programmed) with every specific interval
- ⑤ Chart speed : Printing of chart speed with every specific interval
- ⑥ Alarm Activation/Reset : Printing of time, channel No., alarm type and alarm level when an alarm activates. Printing time, channel No. and alarm level when the alarm is reset. Memory volume is max. 48 data
- ⑦ Programming change mark : Marking when changed parameters are stored
- ⑧ POC mark : Marking when time-axis synchronization is programmed
- ⑨ List printing : Printing of parameters (list 1 or 2) on demand
 List 1: Chart speed, range/printing range, scale, subtract printing, periodic data printing, printing format and alarm
 List 2: Chart speed (3 speeds), alarm output, time-axis synchronization, remote contacts and math expression
 List 3: All parameters (List 1 + List 2)

22. SPECIFICATIONS

ⓂMessage : Printing of message in message No. selected
 Numbers of message: Max. 5
 Message programming: Max. 15 digits

Chart paper: Depending on models

Model	System	Printing width	Total width	Total length
AL3000	Folding type	100mm	114mm	10m
AH3000	Folding type	180mm	200mm	20m

Chart speed: 1 to 600mm/h, 1 to 200mm/h
 Default ... AL3000: 20mm/h
 AH3000: 25mm/h

Chart speed accuracy: Within $\pm 0.1\%$. For the chart scale after feeding 1000mm or more.

Skip function: No display or printing is executed for the channels for which no range is programmed.

Time axis synchronization:

On or off selectable with key operation

Subtract printing:

Printing of difference between measured value and reference channel (or reference value)

Pen lift: Pens are automatically lifted up when printing is off.

3 Indication and Display

Trace printing indication: Bargraph display for each channel

Model	No. or segment	Channel color segment
AL3000	51	5-segment each
AH3000	101	10-segment each

Digital display: 16- and 7-segment LCD with cursor
 16-segment ... Character height: 7.5 mm, orange
 7-segment ... Character height: 6.5 mm, white

Model	16-segment	7-segment
AL3000	1 digit	20 digits
AH3000	1 digit	30 digits

Display items: ① Simultaneous display of measured values for all channels ② Year/month/day (only AL3000) ③ Time ④ Chart speed ⑤ Alarm status

Display switching: Each time [DISP] is pressed, the display item changes.

AL3000 ... ① → ②③④ → ⑤

AH3000 ... ①③④ → ⑤

Measured value display: -9999 to 99999 for each channel (Decimal point can be placed at desired position with the scale programming)

Status: Following 6 status lamps are available.

Display text	Condition to light	Color
RECORD ON	Printing ON	Green
KEY LOCK	Key lock	Blue
ALARM	Alarm occurrence	Red
CHART END	Just before chart paper ends	Red
FAIL	Hardware related to servo mechanism abnormal	Red
POC	Time axis sync. ON	Blue

Chart illumination: CFL

4 Alarm

Alarm point: Numbers of channel x numbers of level (4)

Alarm display: [Alarm] status lamp lights and the measured value blinks at alarm activated channel. Alarm display screen indicates alarm channel and alarm type at level digit.

Alarm type: Selectable from the following 10 types for each alarm point

Absolute value	H: High limit	L: Low limit
	E: High limit with standby	F: Low limit with standby
Rate-of-change *1	U: Increase limit	D: Decrease limit
Difference *2	B: Differential high limit	S: Differential low limit
	J: Differential high limit with standby	K: Differential low limit with standby

*1: Variation range per unit time (Note)

(Note) Measuring cycle x measuring count (1 to 20)

*2: Difference between two channels

Alarm deadband: 0.1 to 9.9% of scale programming range

Alarm output: Option

5 Programming and Operation

Key types: See Section 7.1.

Key functions: See Section 7.2.

Basic operation: Basic operation with keys

① Printing ON/OFF ② Chart paper feeding

③ Operation screen switching

Operation: Operation with keys

Selection of ① Digital data printing *1 ② List printing *1 ③ Message printing *1 and ④ Printing format*2

*1: Operation with remote contacts (option) is also available

*2: Only available with option

Pen change mode: Pen moves to the position to be easily changed.

Standard programming:

Range/printing range, °C/°F computation, chart speed, time, scale, skip, subtract printing, alarm, alarm deadband, periodic time printing, engineering unit, tag, message, burnout, passcode/key lock, input filter

Optional programming:

Alarm output...Relay No., AND/OR, output mode
 Remote contacts...Terminal allocation for operation, 3 chart speeds, operation record position

Printing format...Automatic range-shift printing, compressed/expanded, zone printing

Communications interface...Communications protocol, communications specifications

Math expression...Selection of types, parameters

Totalization...Starting time, interval

Engineering port: All parameters can be programmed with engineering software "PASS" (option) installed on a personal computer

22. SPECIFICATIONS

6 Operation Conditions

Operation conditions: Refer to the following table

Items		Reference operation	Normal operation
Ambient temperature		21 to 25°C	0 to 31°C 31 to 50°C*
Max. ambient humidity		80%RH	80%RH 80 to 50%RH*
Min. ambient humidity		20%RH	20%RH
Power supply voltage		100VAC ± 1%	90 to 264VAC
Power supply frequency		50/60Hz ± 0.5%	50/60Hz ± 2%
Posture	Left/right	0°	0 to 10°
	Forward tilting	0°	0°
	Backward tilting	0°	0 to 30°
Warming-up time		30 min. or more	Not necessary

*Decrease from 80% RH at 31°C, and decrease to 50% at 40°C

Transportation condition:

Ambient temperature/humidity... -20 to 60°C, 5 to 90%RH (without condensation)

Vibration... 10 to 60Hz, 4.9 m/S²*

Impact... 392 m/S²*

* When shipping out from a factory

Storage condition:

Ambient temperature/humidity... -20 to 60°C, 5 to 90%RH (without condensation)

7 General specifications

Rated power voltage: 100 to 240 VAC, 50/60 Hz

Power consumption: Maximum 60V A

Power failure protection: Programmed parameters stored into EEPROM memory. Clock circuit sustained for minimum 8 years by a lithium battery. (8 hours operation per day)

Insulation resistance:

Between primary and protective conductor terminals

... 20MΩ or more at 500 V DC

Between secondary and protective conductor terminals

... 20MΩ or more at 500 V DC

Between primary and secondary terminals

... 20MΩ or more at 500 V DC

Dielectric strength:

Between primary and protective conductor terminals

... 1 minute at 1500 V AC

Between secondary and protective conductor terminals

... 1 minute at 500 V AC

Between primary and secondary terminals

... 1 minute at 2300 V AC

Primary terminals: Power terminals, Alarm output terminals (MOS relay, mechanical relay "a" contact)

Secondary terminals: Measuring input terminals, Remote contacts terminals, Communications interface terminals, Alarm output terminals (Mechanical relay "c" contact),

Case assembly material: Door Frame ... ABS resin

Front plate... Polycarbonate

Enclosure... Steel

Color: Door ... Frame: Black (equivalent to Munsell N3.0)

Front plate: Transparent

Enclosure... Gray (equivalent to Munsell N7.0)

Mounting: Panel mounting

Terminal screws: Power terminals ... M4.0

Terminals other than above ... M3.5

Weight: AL3000 ... Approx. 4.0 kg (with fully options)

AH3000 ... Approx. 9.0 kg (with fully options)

Dimension: AL3000... 144 × 144 × 258 (mm)

AH3000... 288 × 288 × 220 (mm)

Panel cutout : AL3000... 138 × 138 (mm)

AH3000... 281 × 281 (mm)

Clock accuracy: Within ±2 minutes per 30 day

(Under reference operating conditions,

Except errors when power supply is turned

on or off)

Packing material: Layered cardboard is used as cushion material

8 Safety Regulations

CE: Conforms to EMC and low voltage directives

UL: UL3111-1 (Approval pending)

CSA (C-UL): CSA ... C22.2 No.1010 (Approval pending)

IP: Conforms to IEC529 IP54

22. SPECIFICATIONS

9 Accuracy Ratings

No.	Input type	Measuring range	Reference range	Accuracy rating
01	DC (mV)	-13.80 to 13.80mV	±13.8mV	±0.1% ± 1 d
02		-27.60 to 27.60mV	±27.6mV	
03		-69.00 to 69.00mV	±69.0mV	
04		-200.0 to 200.0mV	±200.0mV	
05		-500.0 to 500.0mV	±500.0mV	
06	DC (V)	-2.000 to 2.000V	±2V	
07		-5.000 to 5.000V	±5V	
08		-10.00 to 10.00V	±10V	
09		-20.00 to 20.00V	±20V	
10		-50.00 to 50.00V	±50V	
21	K	-200.0 to 300.0°C	±13.8mV	±0.1% ± 1 d
22		-200.0 to 600.0°C	±27.6mV	
23		-200.0 to 1370 °C	±69.0mV	
24	E	-200.0 to 200.0°C	±13.8mV	
25		-200.0 to 350.0°C	±27.6mV	
26	J	-200 to 900°C	±69.0mV	
27		-200.0 to 250.0°C	±13.8mV	
28	T	-200.0 to 500.0°C	±27.6mV	
29		-200 to 1200°C	±69.0mV	
30	R	-200.0 to 250.0°C	±13.8mV	
31		-200.0 to 400.0°C	±27.6mV	
32	S	0 to 1200 °C	±13.8mV	
33		0 to 1760 °C	±27.6mV	
34	B	0 to 1300 °C	±13.8mV	
35		0 to 1760 °C	±27.6mV	
36	N	0 to 1820 °C	±13.8mV	
37		-200.0 to 400.0°C	±13.8mV	
38		-200.0 to 750.0°C	±27.6mV	
39	W·WRe26	-200 to 1300 °C	±69.0mV	
40		0 to 2315°C	±69.0mV	
41	WRe5·WRe26	0 to 2315°C	±69.0mV	±0.2% ± 1 d
43		PtRh40-PtRh20	0 to 1888°C	
44	NiMo-Ni	-50.0 to 290.0°C	±13.8mV	
45		-50.0 to 600.0°C	±27.6mV	
46		-50 to 1310 °C	±69.0mV	
47	CR-AuFe	0.0 to 280.0K	±13.8mV	
48	Platinel II	0.0 to 350.0°C	±13.8mV	±0.15% ± 1 d
49		0.0 to 650.0°C	±27.6mV	
50		0 to 1395°C	±69.0mV	
51	U	-200.0 to 250.0°C	±13.8mV	
52		-200.0 to 500.0°C	±27.6mV	
53		-200.0 to 600.0°C	±69.0mV	
54	L	-200.0 to 250.0°C	±13.8mV	±0.1% ± 1 d
55		-200.0 to 500.0°C	±27.6mV	
56		-200 to 900°C	±69.0mV	
70	Pt100 (JIS'97)	-140.0 to 150.0°C	160Ω	±0.15% ± 1 d
71		-200.0 to 300.0°C	220Ω	±0.1% ± 1 d
72		-200.0 to 850.0°C	400Ω	
73	Pt100 (QPt100) (JIS'89)	-140.0 to 150.0°C	160Ω	±0.15% ± 1 d
74		-200.0 to 300.0°C	220Ω	±0.1% ± 1 d
75		-200.0 to 649.0°C	400Ω	
76	JPt100	-140.0 to 150.0°C	160Ω	±0.15% ± 1 d
77		-200.0 to 300.0°C	220Ω	±0.1% ± 1 d
78		-200.0 to 649.0°C	400Ω	

No.	Input type	Measuring range	Reference range	Accuracy rating
79	Pt50	-200.0 to 649.0°C	220Ω	±0.1% ± 1 d
80	Pt-Co	4.0 to 374.0K	220Ω	±0.15% ± 1 d

Note) "± 1 d" at accuracy rating stands for ± 1 digit.

Note) Thermocouple inputs do not include reference junction compensation accuracy.

The Indication equivalent to 200 μV may vary under the test environment of EMC directive.

Exceptions to accuracy rating

Input type	Measuring range	Accuracy rating
K, E, J, T, L	-200 to 0°C	±0.2% ± 1 digit
	R, S	
B	0 to 400°C	Not specified
	400 to 800°C	±0.15% ± 1 digit
N, U	-200 to 0°C	±0.3% ± 1 digit
W-WRe26	0 to 100°C	±4% ± 1 digit
	100 to 300°C	±0.5% ± 1 digit
PtRh40-PtRh20	0 to 300°C	±1.5% ± 1 digit
	300 to 800°C	±0.8% ± 1 digit
CR-AuFe	0 to 20K	±0.5% ± 1 digit
	20 to 50K	±0.3% ± 1 digit
Pt100 ('97)	700 to 850°C	±0.15% ± 1 digit
Pt-Co	4 to 50K	±0.3% ± 1 digit

Note) Thermocouple input is converted into the reference range.

22. SPECIFICATIONS

10 Option

1) Alarm outputs

Output types: ① Alarm point output ② FAIL output ③ Chart paper end (C.End) output

Numbers of outputs: AL3000 ... 6 points
AH3000 ... 6 or 12 points

Contact capacity (with resistive load):

① MOS relay output ... 240 V (AC, DC), 50 mA (AC, DC)

② Mechanical relay (Common for "a" and "c" contacts) ...
100VAC 0.5 A, 240VAC 0.2A, 100VDC 0.3 A

Output wiring: AND/OR output selection is available for each alarm points (including FAIL and C.End)

Relay coil phase: Energize/Not energize selectable*

Relay output latch: Hold/Not hold selectable*

Alarm display latch: Hold/Not hold selectable*

*Common to all relays

Dimension: The following length will be added for the depth.
AL3000...14 mm (MOS relay, Mechanical "c" contact)
25 mm (Mechanical "a" contact)
AH3000...16 mm (MOS relay, Mechanical "c" contact)
27 mm (Mechanical "a" contact)

2) Remote contacts

Input terminals: 4 points (Common terminals: 2 points)

Input signal: Contact (Open/Shorted)

Voltage when the contact is open: Approx. 5 V

Current when the contact is shorted: Approx. 2 mA

Operations: Up to 4 input terminals can be selectable in the following table.

Operation	Terminal
① Printing ON/OFF, 3 chart speeds	2
② Message (No.1 to No.5) printing	4
③ Message (No. 1 and No. 2) printing	2
④ Digital data printing	1
⑤ List 1 printing	1
⑥ List 2 printing	1
⑦ List 3 printing	1
⑧ Operation record A	1
⑨ Operation record B	1
⑩ Operation record C	1
⑪ Operation record D	1
⑫ Reset of totalization*	1

*This operation is only available for the "totalization" (option).

3) Printing format

Trace printing format, ① Automatic range shift, ② Compressed/Expanded or ③ Zone scale, is selectable for each channel.. The format ③ is common to all channels.

Automatic range-shift	Printing area can be divided up to 5 ranges. It switches the range according to the measured values automatically for printing.
Compressed/Expanded	Specific printing range is compressed or expanded for printing.
Zone scale	Printing area is divided into 2 to 4 zones*. Data of each channel is printed in the relevant zone. *AL3000 ... 2, AH3000 ... 2 to 4

4) Others

Options	Detail
Communications interface*	Specify one of the following modes. RS-232C, RS-422A, RS-485
Input resistance for current input*	Capable up to ± 50 mA DC by connecting an input resistance to the measuring input terminal. 100 Ω : Applicable current ± 50 mA 250 Ω : Applicable current ± 20 mA
Math expression*	One of following math expressions is selectable for each channel. Addition, subtraction, multiplication, division, natural logarithm, logarithm, exponential, square root, temperature/humidity, maximum, minimum, average value, absolute value, data communications input*, flow rate compensation. *This function is only available for the "communications interface" (option).
Totalizing*	Totalizing measured values and calculation results. Reset function is executed with programmed intervals or remote contacts signals*. *This function is only available for the "remote contacts" (option).
Transmitter power supply*	Power supply unit for the transmitter generating input signal to the recorder
16 m chart paper	AL3000 only Total chart paper length of 15.6 m

* Exclusive instruction manual is provided.

CHINO

CHINO CORPORATION

32-8, KUMANO-CHO, ITABASHI-KU, TOKYO 173-8632

Telephone: 81-3-3956-2171

Facsimile: 81-3-3956-0915



Printed in Japan ()